



Cynthia Vodopivec  
Dynegy Zimmer, LLC  
Luminant  
6555 Sierra Dr.  
Irving, TX 75039

September 29, 2020

Sent via email

Mr. Andrew R. Wheeler, EPA Administrator  
Environmental Protection Agency  
1200 Pennsylvania Avenue, N.W.  
Mail Code 5304-P  
Washington, DC 20460

Re: Zimmer Power Station Alternative Closure Demonstration

Dear Administrator Wheeler:

Dynegy Zimmer, LLC (Dynegy) hereby submits this request to the U.S. Environmental Protection Agency (EPA) for approval for a site-specific alternative deadline to initiate closure pursuant to 40 C.F.R. § 257.103(f)(1) for the three CCR surface impoundments (Coal Pile Runoff Pond, Gypsum Recycle Pond, and D Basin) located at the Zimmer Power Station near Moscow, Ohio. Dynegy is requesting an extension pursuant to 40 C.F.R. § 257.103(f)(1) to allow the three impoundments to continue to receive CCR and non-CCR wastestreams after April 11, 2021, in order to retrofit the Coal Pile Runoff Pond, reroute CCR wastestreams away from the Gypsum Recycle Pond to the Mercury Effluent Treatment System, close the Gypsum Recycle Pond and repurpose as a non-CCR basin, and initiate closure of D Basin. The Coal Pile Runoff Pond and Gypsum Recycle Pond are eligible unlined CCR surface impoundments as defined under 40 C.F.R. § 257.53.

Enclosed is a demonstration prepared by Burns & McDonnell that addresses all of the criteria in 40 C.F.R. § 257.103(f)(1)(i)-(iii) and contains the documentation required by 40 C.F.R. § 257.103(f)(1)(iv). As allowed by the agency, in lieu of hard copies of these documents, electronic files were submitted to Kirsten Hillyer, Frank Behan, and Richard Huggins via email. If you have any questions regarding this submittal, please contact Phil Morris at 618-343-7794 or phil.morris@vistracorp.com.

Sincerely,

A handwritten signature in black ink that reads "Cynthia E. Vodopivec".

Cynthia Vodopivec  
VP - Environmental Health & Safety

Enclosure

cc: Kirsten Hillyer  
Frank Behan  
Richard Huggins

# Zimmer CCR Surface Impoundments Demonstration for a Site-Specific Alternative to Initiation of Closure Deadline



**Dynegy Zimmer, LLC**

**William H. Zimmer Power Station  
Project No. 122702**

**Revision 0  
September 28, 2020**

# **Zimmer CCR Surface Impoundments Demonstration for a Site- Specific Alternative to Initiation of Closure Deadline**

Prepared for

**Dynegy Zimmer, LLC  
William H. Zimmer Power Station  
Project No. 122702**

**Moscow, Ohio**

**Revision 0  
September 28, 2020**

Prepared by

**Burns & McDonnell Engineering Company, Inc.  
Kansas City, Missouri**

## INDEX AND CERTIFICATION

**Dynegy Zimmer, LLC**  
**Zimmer CCR Surface Impoundments**  
**Demonstration for a Site-Specific Alternative to Initiation of Closure Deadline**

### Report Index

<u>Chapter Number</u>	<u>Chapter Title</u>	<u>Number of Pages</u>
1.0	Introduction	3
2.0	Workplan	15
4.0	Conclusion	1
Appendix A	Site Plan and Water Balance Diagram	2
Appendix B	Schedule	2

### Certification

I hereby certify, as a Professional Engineer in the state of Ohio, that the information in this document as noted in the above Report Index was assembled under my direct personal charge. This report is not intended or represented to be suitable for reuse by the Dynegy Zimmer, LLC or others without specific verification or adaptation by the Engineer.

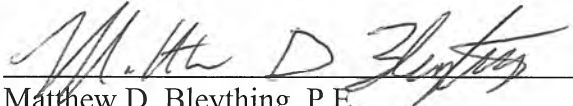

  
\_\_\_\_\_  
Matthew D. Bleything, P.E.  
Ohio License No. 82440

Date: 9/28/2020



## TABLE OF CONTENTS

	<u>Page No.</u>
<b>1.0 INTRODUCTION .....</b>	<b>1-1</b>
<b>2.0 WORKPLAN .....</b>	<b>2-1</b>
2.1 No Alternative Disposal Capacity and Approach to Obtain Alternative Capacity - § 257.103(f)(1)(iv)(A)(1) .....	2-1
2.1.1 CCR Wastestreams .....	2-2
2.1.2 Non-CCR Wastestreams .....	2-3
2.1.3 Site-Specific Conditions Supporting Alternative Capacity Approach – § 257.103(f)(1)(iv)(A)(1)(i) .....	2-5
2.1.5 Options Considered Both On and Off-Site to Obtain Alternative Capacity .....	2-6
2.1.6 Approach to Obtain Alternative Capacity.....	2-7
2.1.7 Technical Infeasibility of Obtaining Alternative Capacity .....	2-10
2.1.8 Justification for Time Needed to Complete Development of Alternative Capacity Approach – § 257.103(f)(1)(iv)(A)(1)(iii).....	2-10
2.2 Detailed Schedule to Obtain Alternative Disposal Capacity - § 257.103(f)(1)(iv)(A)(2).....	2-11
2.3 Narrative of Schedule and Visual Timeline - § 257.103(f)(1)(iv)(A)(3).....	2-11
2.4 Progress Towards Obtaining Alternative Capacity - § 257.103(f)(1)(iv)(A)(4).....	2-15
<b>3.0 DOCUMENTATION AND CERTIFICATION OF COMPLIANCE .....</b>	<b>3-1</b>
3.1 Owner’s Certification of Compliance - § 257.103(f)(1)(iv)(B)(1) .....	3-1
3.2 Visual Representation of Hydrogeologic Information - § 257.103(f)(1)(iv)(B)(2) .....	3-1
3.3 Groundwater Monitoring Results - § 257.103(f)(1)(iv)(B)(3).....	3-2
3.4 Description of Site Hydrogeology - § 257.103(f)(1)(iv)(B)(4) .....	3-2
3.5 Corrective Measures Assessment - § 257.103(f)(1)(iv)(B)(5).....	3-2
3.6 Remedy Selection Progress Report - § 257.103(f)(1)(iv)(B)(6).....	3-2
3.7 Structural Stability Assessment - § 257.103(f)(1)(iv)(B)(7).....	3-2
3.8 Safety Factor Assessment - § 257.103(f)(1)(iv)(B)(8) .....	3-2
<b>4.0 CONCLUSION .....</b>	<b>4-1</b>
<b>APPENDIX A – SITE PLAN AND WATER BALANCE DIAGRAM</b>	
<b>APPENDIX B – SCHEDULE</b>	
<b>APPENDIX C – COMPLIANCE DOCUMENTS</b>	

---

## LIST OF TABLES

	<b><u>Page No.</u></b>
Table 2-1: Zimmer CCR Surface Impoundment Summary .....	2-2
Table 2-2: Zimmer CCR Wastestreams .....	2-3
Table 2-3: Zimmer Gypsum Recycle Pond Non-CCR Wastestreams .....	2-4
Table 2-4: Zimmer Coal Pile Runoff Pond Non-CCR Wastestreams .....	2-4
Table 2-5: Alternatives for Disposal Capacity.....	2-6
Table 2-6: Retrofit Project Progress Milestones.....	2-10

## LIST OF ABBREVIATIONS

<b><u>Abbreviation</u></b>	<b><u>Term/Phrase/Name</u></b>
CCR	Coal Combustion Residual
CFR	Code of Federal Regulations
CY	Cubic yards
Dynergy	Dynergy Zimmer, LLC
ELG	Effluent Limitations Guidelines and Standards for the Steam Electric Power Generating Point Source Category
EPA	Environmental Protection Agency
FGD	Flue Gas Desulfurization
GCL	Geosynthetic Clay Liner
GWPS	Groundwater Protection Standards
HDPE	High Density Polyethylene
RCRA	Resource Conservation and Recovery Act
SAP	Sampling and Analysis Plan
SSI(s)	Statistically Significant Increases
SSL(s)	Statistically Significant Levels
Zimmer	William H. Zimmer Power Station

## 1.0 INTRODUCTION

On April 17, 2015, the Environmental Protection Agency (EPA) issued the federal Coal Combustion Residual (CCR) Rule, 40 C.F.R. Part 257, Subpart D, to regulate the disposal of CCR materials generated at coal-fueled electric generating units. The rule is being administered under Subtitle D of the Resource Conservation and Recovery Act (RCRA, 42 U.S.C. § 6901 *et seq.*).

On August 28, 2020, the EPA Administrator issued revisions to the CCR Rule that require all unlined surface impoundments to cease receipt of CCR and non-CCR waste and initiate closure by April 11, 2021, unless an alternative deadline is requested and approved. 40 C.F.R. § 257.101(a)(1), (b)(1) (85 Fed. Reg. 53,516 (Aug. 28, 2020)). Specifically, owners and operators of a CCR surface impoundment may seek and obtain an alternative closure deadline by demonstrating that there is currently no alternative capacity available on or off-site and that it is not technically feasible to complete the development of alternative capacity prior to April 11, 2021. 40 C.F.R. § 257.103(f)(1). To make this demonstration, the facility is required to provide detailed information regarding the process the facility is undertaking to develop the alternative capacity. 40 C.F.R. § 257.103(f)(1). Any extensions granted cannot extend past October 15, 2023, except an extension can be granted until October 15, 2024, if the impoundment qualifies as an “eligible unlined CCR surface impoundment” as defined by the rule. 40 C.F.R. § 257.103(f)(1)(vi). Regardless of the maximum time allowed under the rule, EPA explains in the preamble to the Part A rule that each impoundment “must still cease receipt of waste as soon as feasible, and may only have the amount of time [the owner/operator] can demonstrate is genuinely necessary.” 85 Fed. Reg. at 53,546.

This document serves as Dynegy’s Demonstration for a site-specific alternative deadline to initiate retrofit or closure pursuant to 40 C.F.R. § 257.103(f)(1) for the CCR surface impoundments at the William H. Zimmer Power Station (Zimmer), located in Moscow, Ohio, which include the following:

- Gypsum Recycle Pond
- Coal Pile Runoff Pond
- D Basin

The Gypsum Recycle Pond and Coal Pile Runoff are “eligible unlined CCR surface impoundments” as defined under 40 C.F.R. § 257.53. To obtain an alternative closure deadline under 40 C.F.R. § 257.103(f)(1), a facility must meet the following three criteria:

1. **§ 257.103(f)(1)(i)** - There is no alternative disposal capacity available on-site or off-site. An increase in costs or the inconvenience of existing capacity is not sufficient to support qualification;

2. **§ 257.103(f)(1)(ii)** - Each CCR and/or non-CCR wastestream must continue to be managed in that CCR surface impoundment because it was technically infeasible to complete the measures necessary to obtain alternative disposal capacity either on or off-site of the facility by April 11, 2021; and
3. **§ 257.103(f)(1)(iii)** - The facility is in compliance with all the requirements of the CCR Rule.

To demonstrate that the first two criteria above have been met, 40 C.F.R. § 257.103(f)(1)(iv)(A) requires the owner or operator to submit a work plan that contains the following elements:

- A written narrative discussing the options considered both on and off-site to obtain alternative capacity for each CCR and/or non-CCR wastestream, the technical infeasibility of obtaining alternative capacity prior to April 11, 2021, and the option selected and justification for the alternative capacity selected. The narrative must also include all of the following:
  - An in-depth analysis of the site and any site-specific conditions that led to the decision to select the alternative capacity being developed;
  - An analysis of the adverse impact to plant operations if the CCR surface impoundment in question were to no longer be available for use; and
  - A detailed explanation and justification for the amount of time being requested and how it is the fastest technically feasible time to complete the development of the alternative capacity.
- A detailed schedule of the fastest technically feasible time to complete the measures necessary for alternate capacity to be available, including a visual timeline representation. The visual timeline must clearly show all of the following:
  - How each phase and the steps within that phase interact with or are dependent on each other and the other phases;
  - All of the steps and phases that can be completed concurrently;
  - The total time needed to obtain the alternative capacity and how long each phase and step within each phase will take; and
  - At a minimum, the following phases: engineering and design, contractor selection, equipment fabrication and delivery, construction, and start up and implementation.
- A narrative discussion of the schedule and visual timeline representation, which must discuss the following:
  - Why the length of time for each phase and step is needed and a discussion of the tasks that occur during the specific step;
  - Why each phase and step shown on the chart must happen in the order it is occurring;
  - The tasks that occur during each of the steps within the phase; and
  - Anticipated worker schedules.

- A narrative discussion of the progress the owner or operator has made to obtain alternative capacity for the CCR and/or non-CCR wastestreams. The narrative must discuss all the steps taken, starting from when the owner or operator initiated the design phase up to the steps occurring when the demonstration is being compiled. It must discuss where the facility currently is on the timeline and the efforts that are currently being undertaken to develop alternative capacity.

To demonstrate that the third criterion above has been met, 40 C.F.R. § 257.103(f)(1)(iv)(B) requires the owner or operator to submit the following information:

- A certification signed by the owner or operator that the facility is in compliance with all of the requirements of 40 C.F.R. Part 257, Subpart D;
- Visual representation of hydrogeologic information at and around the CCR unit(s) that supports the design, construction and installation of the groundwater monitoring system. This includes all of the following:
  - Map(s) of groundwater monitoring well locations in relation to the CCR unit(s);
  - Well construction diagrams and drilling logs for all groundwater monitoring wells; and
  - Maps that characterize the direction of groundwater flow accounting for seasonal variations.
- Constituent concentrations, summarized in table form, at each groundwater monitoring well monitored during each sampling event;
- A description of site hydrogeology including stratigraphic cross-sections;
- Any corrective measures assessment conducted as required at § 257.96;
- Any progress reports on corrective action remedy selection and design and the report of final remedy selection required at § 257.97(a);
- The most recent structural stability assessment required at § 257.73(d); and
- The most recent safety factor assessment required at § 257.73(e).

## 2.0 WORKPLAN

To demonstrate that the criteria in 40 C.F.R. § 257.103(f)(1)(i) and (ii) have been met, the following is a workplan, consisting of the elements required by § 257.103(f)(1)(iv)(A). Specifically, this workplan documents that there is no alternative capacity available on or off-site for each of the CCR and non-CCR wastestreams that Dynegy plans to continue to manage in the three surface impoundments and discusses the options considered for obtaining alternative disposal capacity. As discussed in more detail below, **Dynegy has elected to retrofit the Coal Pile Runoff Pond, reroute CCR wastestreams away from the Gypsum Recycle Pond to the Mercury Effluent Treatment System, close the Gypsum Recycle Pond and repurpose as a non-CCR basin, and initiate closure of D Basin.** The workplan provides a detailed schedule for the retrofit project, including a narrative description of the schedule and an update on the progress already made toward obtaining the alternative capacity. In addition, the narrative includes an analysis of the site-specific conditions that led to the decision to retrofit impoundments and an analysis of the adverse impact to plant operations if Dynegy were no longer able to use the CCR surface impoundments.

### 2.1 No Alternative Disposal Capacity and Approach to Obtain Alternative Capacity - § 257.103(f)(1)(iv)(A)(1)

Dynegy owns and operates Zimmer, a 1,450-megawatt coal-fired facility located in Moscow, Ohio. Zimmer has three CCR surface impoundments (listed in Table 2-1) that receive both CCR and non-CCR wastestreams. The other impoundments onsite (A Basin, B Basin, C Basin, Wastewater Pond and Clear Water Pond) are not authorized to receive CCR material and are not large enough to independently store and/or treat the total volume of the plant non-CCR wastestreams, and specifically coal pile runoff. An aerial view of the Zimmer site and the CCR surface impoundments can be found on Figure 1 in Appendix A, and the impoundments are also shown on the site water balance diagram on Figure 2 in Appendix A. Note, the Gypsum Recycle Pond (also referred to as the Truck Wash Pond) is denoted as the FGD Runoff Pond on the water balance.

**Table 2-1: Zimmer CCR Surface Impoundment Summary**

CCR Surface Impoundment Name	Alternate Designation (see Figure 2)	Year Placed in Service	Impoundment Size (acres) / Storage Volume (acre-feet)	Lined?	Meets Location Restrictions?	Groundwater Status
Gypsum Recycle Pond	SPD-4 Pond-4 Truck Wash Pond	1995	0.6 / 4.5	Yes <sup>1</sup>	Yes	Assessment Monitoring was initiated in May 2018 and is ongoing. No exceedances of Appendix IV parameters have been identified; therefore, an assessment of corrective measures is not required.
Coal Pile Runoff Pond	SPD-3 Pond-3 Coal Pile Runoff Pond	1987	2.8 / 36.3	Yes <sup>1</sup>	Yes	
D Basin	SPD-5 Pond-5 D Basin Dredge Dewatering Basin	2003	6.1 / 46.6	No	No <sup>2</sup>	

<sup>1</sup>Originally classified as lined per 40 C.F.R. § 257.71(a)(1)(i), which was subsequently vacated by the U.S. Court of Appeals for the D.C. Circuit. This impoundment now qualifies as an eligible unlined CCR surface impoundment per § 257.53.

<sup>2</sup>Meets criteria for wetlands, fault areas, seismic impact zones, and unstable areas but not aquifer separation.

### 2.1.1 CCR Wastestreams

Dynegy evaluated each CCR wastestream placed in the Zimmer CCR surface impoundments. The existing site water balance is included in Appendix A of this demonstration (see Figure 2). The Zimmer fly ash, economizer ash, and gas recirculation ash systems are dry handled and disposed in the CCR landfill onsite. The bottom ash (and non-CCR pyrites) are sluiced to dewatering bins equipped with surge tanks and a recirculation system. After dewatering, the bottom ash is disposed in the CCR landfill onsite. For the reasons discussed below in Table 2-2, each of the following CCR wastestreams must continue to be placed in the CCR surface impoundments due to lack of alternative capacity both on and off-site.



**Table 2-2: Zimmer CCR Wastestreams**

CCR Wastestream	Average Flow (MGD)	Description	Dynegy Notes
FGD Wastewater	Intermittent	<p>The FGD system utilizes a series of thickeners with rakes and centrifuges to remove suspended solids and a magnesium recovery process to remove dissolved solids from the effluent.</p> <p>The Gypsum Recycle Pond receives centrate centrifuge effluent, FGD blowdown that is not recycled back to the scrubber, and mag thickener overflow (FGD wastewater). This pond effluent is forwarded to the Mercury Effluent Treatment System via the FGD area sump.</p> <p>Coal Pile Runoff Pond receives treated flow (including CCR solids) from the Mercury Effluent Treatment System.</p> <p>D Basin is used to dewater dredged CCR and non-CCR material from other ponds onsite (including Gypsum Recycle Pond and Coal Pile Runoff Pond).</p>	<p>The Gypsum Recycle Pond is integral to operation of the FGD and captures large portions of the wet-generated CCR solids from the centrate/mag thickener system overflows and various wash activities before having the water forwarded to the Mercury Effluent Treatment System.</p> <p>The Coal Pile Runoff Pond receives both coal fines from non-CCR wastestreams (specifically coal pile runoff), the effluent from the Mercury Effluent Treatment System (including landfill leachate, FGD wastewater, and the CCR solids that settle out of the FGD wastewater. Based on the size of this impoundment, dredging (to D Basin) is required to remove CCR and non-CCR materials on a periodic basis to maintain the residence time and treatment capacity provided within the Coal Pile Runoff Pond.</p> <p>Adequate alternate treatment systems do not exist at the Zimmer site.</p>

### 2.1.2 Non-CCR Wastestreams

Zimmer discharges non-contact cooling water, reclaim water, and cooling tower blowdown via Outfall 099, cooling tower overboard, sewage treatment plant, and south plant stormwater via Outfall 003, and sewage treatment flows and north plant stormwater via Outfall 004. The CCR surface impoundments, two other coal pile runoff ponds (A and B basins), a stormwater and river dredge pond (C Basin), and one low volume wastewater pond are used to manage all the remaining water process flows and stormwater on the plant site. These ponds are interconnected in series to allow for settling prior to overflowing to the Clear Water Pond for discharge to the Ohio River via Outfall 005. The existing site water balance is included in Appendix A of this demonstration (see Figure 2).

Dynegy evaluated each non-CCR wastestream placed in the Zimmer CCR surface impoundments. For the reasons discussed below in Table 2-3 and Table 2-4, each of the following non-CCR wastestreams must continue to be placed in the Gypsum Recycle Pond and Coal Pile Runoff Pond, respectively, due to lack of alternative capacity both on and off-site. The D Basin only receives wastestreams during dredging of other impoundments onsite.

**Table 2-3: Zimmer Gypsum Recycle Pond Non-CCR Wastestreams**

Non-CCR Wastestream	Average Flow (MGD)	Description	Dynegy Notes
Stormwater runoff and wash water	Unknown/ Not Metered	Stormwater runoff from the FGD pad mix stackout pile and wash water from the associated truck wash system.	These flows are intermittent and collected in the impoundment via gravity drainage. Dynegy will need to employ temporary diversion measures to pump this water to the FGD stabilization area sump while the Gypsum Recycle Pond is being closed by removal. Once the CCR wastestreams are modified to bypass the Gypsum Recycle Pond and it has been closed by removal of CCR solids, it will be repurposed as a non-CCR basin and will continue to receive these flows.
Misc Process Wastewater	Unknown/ Not Metered	Includes drainage from the FGD Waste Handling Building, Coal Conveyor 56E/W, and Fly Ash Silo (via the trench system).	

**Table 2-4: Zimmer Coal Pile Runoff Pond Non-CCR Wastestreams**

Non-CCR Wastestream	Average Flow (MGD)	Description	Dynegy Notes
Coal Pile Runoff from A and B Basins	Unknown/ Not Metered	Flow is pumped from the Basins to the Coal Pile Runoff Pond which overflows to the Wastewater Pond.	These flows will be temporarily rerouted to D Basin until the pond retrofit project is complete. The D Basin effluent will need to be pumped to the Wastewater Pond. Rerouting flows will require installation of temporary piping.  If the Coal Pile Runoff Pond were bypassed, the Wastewater Pond residence time would likely not provide adequate treatment to remove the coal fines and Zimmer would risk violating the discharge limits at Outfall 005.
Decant water and stormwater from C Basin	Unknown/ Not Metered		
Decant water and stormwater from D Basin	0.09 - 1.95	Decant water flow is pumped from D Basin to the Coal Pile Runoff Pond during dredging operations and as needed due to stormwater.	

Non-CCR Wastestream	Average Flow (MGD)	Description	Dynergy Notes
Landfill Leachate and Contact Stormwater	0.298	Routed through the Mercury Effluent Treatment System	The Mercury Effluent Treatment System discharge (including CCR and non-CCR wastestreams) will be redirected to the D-Basin through temporary piping during retrofit of the Coal Pile Runoff Pond.

**2.1.3 Site-Specific Conditions Supporting Alternative Capacity Approach – § 257.103(f)(1)(iv)(A)(1)(i)**

As shown on Figure 1 in Appendix A, Zimmer is bounded by the Ohio River to the west, village of Moscow to the south, Ohio River Scenic Byway (US Highway 52) to the east, and residential properties to the north. As such, there is not sufficient space available for the construction of a new pond(s) to store the CCR and non-CCR wastestreams. Further, the remaining impoundments onsite (A Basin, B Basin, C Basin, Wastewater Pond and Clear Water Pond) are not authorized to receive CCR material and are not large enough to independently store and/or treat the total volume of the plant non-CCR wastestreams, specifically coal pile runoff. Consequently, in order to continue to operate and generate electricity, Zimmer must continue to use the Coal Pile Runoff Pond and Gypsum Recycle Pond for treatment of both CCR and non-CCR wastestreams until the Coal Pile Runoff Pond can be retrofitted and Gypsum Recycle Pond inflows can be rerouted. The D Basin must remain open to receive CCR wastestreams during these modifications and will be closed once these projects are completed.

**2.1.4 Impact to Plant Operations if Alternative Capacity Not Obtained – § 257.103(f)(1)(iv)(A)(1)(ii)**

Each CCR surface impoundment is essential to plant operations as noted in Table 2-2, Table 2-3, and Table 2-4. The CCR surface impoundments receive CCR flows and a portion of the non-CCR wastewater flows onsite. The other impoundments onsite (A Basin, B Basin, C Basin, Wastewater Pond and Clear Water Pond) are not authorized to receive CCR material and are not large enough to independently store and/or treat the total volume of the plant non-CCR wastestreams, and specifically coal pile runoff. If these impoundments were removed from service prior to the requested site-specific deadline to initiate closure, the plant would be forced to cease operation. Furthermore, many of the non-CCR wastestreams are sourced from storm events and would not be possible to cease routing to these impoundments before April 11, 2021, even if the plant were idled to develop alternative disposal capacity for these wastestreams.

Consequently, in order to continue to operate and generate electricity and meet the discharge permit requirements, Zimmer must continue to use the Gypsum Recycle Pond and Coal Pile Runoff Pond for

treatment of both CCR and non-CCR wastestreams until the Coal Pile Runoff Pond can be retrofitted with a CCR-compliant liner system and new effluent tanks can be installed for storage and redirection of the Gypsum Recycle Pond CCR wastestreams. Zimmer must also continue to use the D Basin to receive intermittent CCR and non-CCR wastestreams until the necessary modifications can be completed for the other impoundments onsite.

### 2.1.5 Options Considered Both On and Off-Site to Obtain Alternative Capacity

The options considered for alternative disposal capacity of the wastestreams currently routed to the CCR surface impoundments are summarized in Table 2-5. Additional details on the CCR and non-CCR wastestreams included in this demonstration request are found in Table 2-2, Table 2-3, and Table 2-4.

**Table 2-5: Alternatives for Disposal Capacity**

Alternative Capacity Technology	Average Time to Construct (Months) <sup>1</sup>	Feasible at Zimmer?	Selected?	Dynergy Notes
Conversion to dry handling	33.8	Yes	No	The bottom ash and fly ash wastestreams are dry handled or high recycle rate systems compliant with EPA regulations and not currently routed to the unlined CCR surface impoundments onsite, thus this technology option would not address Zimmer's alternative capacity needs.
Non-CCR wastewater basin	23.5	No	No	There is not adequate available real estate onsite within reasonable proximity to the plant to construct a new non-CCR wastewater basin.
Wastewater treatment facility	22.3	No	No	There is not adequate available real estate onsite within reasonable proximity to the plant to construct a new wastewater treatment facility.
New CCR surface impoundment	31	No	No	There is not adequate available real estate onsite within reasonable proximity to the plant to construct a new CCR surface impoundment.
Retrofit of a CCR surface impoundment	29.8	Yes	Yes	Dynergy plans to pursue this option for the Coal Pile Runoff Pond.
Multiple technology system	39.1	Yes	Yes	In addition to retrofitting the Coal Pile Runoff Pond, Dynergy plans to reroute CCR flows away from the Gypsum Recycle Pond to a new collection tank. Once the Gypsum Recycle Pond is closed by removal, the pond will be repurposed as a non-CCR basin.

Alternative Capacity Technology	Average Time to Construct (Months) <sup>1</sup>	Feasible at Zimmer?	Selected?	Dynegy Notes
Temporary treatment system	Not defined	No	No	The Coal Pile Runoff pond provides residence time for treatment of the surges from rain events with over eleven million gallons of storage. Dynegy has chosen to focus on implementing the necessary measures for the selected technologies described above rather than try to develop temporary solutions for treatment of the remaining CCR and/or non-CCR wastestreams.

<sup>1</sup>From Table 3. See 85 Fed. Reg. at 53,534.

As EPA explained in the preamble of the 2015 rule, it is not possible for sites that sluice CCR material to an impoundment to eliminate the impoundment and dispose of the material offsite. *See* 80 Fed. Reg. 21,301, 21,423 (Apr. 17, 2015) (“[W]hile it is possible to transport dry ash off-site to [an] alternate disposal facility that is simply not feasible for wet-generated CCR. Nor can facilities immediately convert to dry handling systems.”). Dynegy agrees with EPA in this assessment and confirms that off-site alternatives are not an option for wet-generated CCR and non-CCR wastestreams. There are no feasible offsite-disposal options for the wet-generated wastestreams at Zimmer.

### 2.1.6 Approach to Obtain Alternative Capacity

Dynegy installed monitoring wells in 2015 and performed background groundwater sampling between December of 2015 and July of 2017. During this time, several engineering firms assisted Dynegy in preparing the required CCR compliance documentation which Dynegy posted on its public CCR website. Key information is summarized in Table 2-1. The D Basin was certified as an unlined impoundment; however, the Coal Pile Runoff Pond and the Gypsum Recycle Pond were originally classified as lined per 40 C.F.R. § 257.71(a)(1)(i), which was subsequently vacated by the U.S. Court of Appeals for the D.C. Circuit. Accordingly, pursuant to 40 C.F.R. § 257.101(a)(1), these three ponds are now required to cease receiving CCR and non-CCR flows by April 11, 2021 and either complete a retrofit or initiate closure by that date.

In February of 2020, Dynegy hired Burns & McDonnell to evaluate the impacts to the plant from both the proposed CCR Rule and proposed ELG Rule changes and provide potential compliance options. The potential options examined for CCR Rule compliance included the following:

- Option A: Retrofit Coal Pile Runoff Pond and Gypsum Recycle Pond with a composite liner, removing solids from D Basin and abandoning in place. Install a concrete pad for geotextile tube layout during future dredging efforts. These tubes would receive dredge flows, capture the solids, and the pad would capture the decant water which would be returned to the Coal Pile Runoff Pond.
- Option B: Include Option A scope and retrofit D Basin with a composite liner and a drainage collection layer to support future dredging efforts in place of the concrete pad solution.
- Option C: Include Option A scope without the concrete pad. Future dredging efforts would involve alternate measures such as mobile filter presses or temporary liners for geotextile tube laydown areas.
- Option D: Install a composite liner in the D Basin and the Gypsum Recycle Pond, reroute the flows from the Mercury Effluent Treatment System to the retrofitted D Basin, and clean out the Coal Pile Runoff Pond. The Coal Pile Runoff Pond would no longer be considered a CCR impoundment and would remain in service as a process wastewater pond. Future dredging efforts would be performed similar to Option C; however, the frequency of this dredging is expected to be significantly reduced based on the larger size of D Basin.
- Option E: Reroute the centrate centrifuge effluent and magnesium thickener effluent directly to the Mercury Effluent Treatment System (bypassing the Gypsum Recycle Pond), remove solids from the Gypsum Recycle Pond and close the Gypsum Recycle Pond in accordance with the CCR Rule and construct a non-CCR impoundment in its place, temporarily direct the Mercury Effluent Treatment System effluent to D Basin, retrofit the Coal Pile Runoff Pond with a composite liner, and close the D Basin.

Dynegy investigated the possibility for meeting the alternate liner demonstration allowed under the proposed Part B Rule. The final requirements for this are unknown at this time; however, Dynegy has since elected to proceed with modifying plant operations and retrofitting the Coal Pile Runoff Pond at Zimmer. Dynegy has selected the Option E approach, which includes removal of CCR material and relocation of the CCR flows away from the Gypsum Recycle Pond to allow for Dynegy to close the pond and repurpose the pond as a non-CCR impoundment, retrofit of the Coal Pile Runoff Pond, and closure of the D Basin (once the retrofit of the Coal Pile Runoff Pond is completed). This selection was based on comparison of capital cost, O&M cost, and several business factors. The proposed retrofit project would include the following general scope and sequence:

- Relocate the CCR wastestreams from the Gypsum Recycle Pond:

- Install a 20,000-gallon agitated tank to receive the magnesium thickener overflow and a set of pumps to pump this water directly to the Mercury Effluent Treatment System through 3,300 feet of new 6” HDPE piping
- Install 3,300 feet of new 3” HDPE piping to direct the effluent from the centrate system to the Mercury Effluent Treatment System
- Isolate the Coal Pile Runoff Pond to allow for retrofit:
  - Temporarily reroute flows from the Mercury Effluent Treatment System to D Basin. Once the CCR solids are removed, the remaining water can be discharged to the Wastewater Pond.
  - Temporarily route flows from A, B, and C Basins to D Basin, and from D Basin to the Wastewater Pond. This activity allows for storm surges to be contained in the D Basin prior to routing flow to the Wastewater Pond, minimizing impacts to the residence time of that pond.
- Dewater the Coal Pile Runoff and Gypsum Recycle Ponds (removing any free water to the Wastewater Pond)
- Remove any remaining CCR material and other sediment from the ponds. The material will be temporarily staged within the ponds (or the adjacent stackout pad for the Gypsum Recycle Pond) to further dewater prior to being loaded onto trucks for transport to the onsite CCR Landfill.
- Retrofit the Coal Pile Runoff Pond pursuant to the retrofit criteria in 40 C.F.R. § 257.102(k):
  - Remove the existing bottom liner system (3-feet of clay) by excavating and hauling the material to the onsite CCR Landfill.
  - Install a composite liner system including a geosynthetic clay liner (GCL) overlain by a 60-mil high-density polyethylene (HDPE) geomembrane.
  - Install geotextile, 12 inches of crushed rock over the pond bottom, and 15 inches of riprap over the pond slopes.
- Return the Mercury Effluent Treatment System discharge, as well as the discharge from the A, B, and C Basins, to the Coal Pile Runoff Pond and initiate closure of the D Basin. The closure of D Basin is not considered part of this Demonstration, as it will occur after the requested site-specific alternative deadline to initiate closure.
- Close the Gypsum Recycle Pond by removing CCR material in accordance with 40 C.F.R. § 257.102(c). Then repurpose the pond as a non-CCR surface impoundment which will receive stormwater, wash water, and other low-volume wastewater. The new non-CCR surface impoundment discharge will likely bypass the Mercury Effluent Treatment System and be routed directly to the Wastewater Pond.

### 2.1.7 Technical Infeasibility of Obtaining Alternative Capacity

The Coal Pile Runoff Pond and Gypsum Recycle Pond are “eligible unlined CCR surface impoundments,” and thus were not previously subject to closure. Dynegy began its selected compliance project execution for Zimmer with scoping studies in early 2020 and is in the process of procuring engineering services for detailed design for the preferred compliance approach. Consequently, it is not possible to implement the measures discussed above in a way that would likely be successful by April 11, 2021.

The conditions at Zimmer demonstrate that no alternative disposal capacity is available on-site or off-site, satisfying the requirement of 40 C.F.R. § 257.103(f)(1)(i), and Dynegy respectfully requests a site-specific extension of the deadline to initiate closure of the CCR surface impoundments until the date on which those actions are expected to be completed. Dynegy will need until October 20, 2021 to reroute the CCR wastestreams away from the Gypsum Recycle Pond, complete the closure of the Gypsum Recycle Pond, retrofit the Coal Pile Runoff Pond, and to cease routing all CCR and non-CCR flows to D Basin and initiate its closure.

### 2.1.8 Justification for Time Needed to Complete Development of Alternative Capacity Approach – § 257.103(f)(1)(iv)(A)(1)(iii)

The schedule for developing alternative disposal capacity is described in more detail in Sections 2.2 and 2.3. The milestones for progress are summarized in Table 2-6 below. Dynegy believes this represents the fastest technically feasible timeframe for compliance at Zimmer, and these durations are consistent with EPA’s assessment that 4-12 months accurately reflects the amount of time needed to retrofit a small surface impoundment. *See* 85 Fed. Reg. at 53,529.

**Table 2-6: Retrofit Project Progress Milestones**

Year or Progress Reporting Period	Status	Milestone Description	Dynegy Notes
2020	Completed	Evaluate retrofit scenarios, choose preferred option	Dynegy is in the process of procuring engineering services for detailed design.
2020	On Schedule	Procure engineering services for detailed design	



Year or Progress Reporting Period	Status	Milestone Description	Dynegy Notes
April 30, 2021	Scheduled	Complete detailed design for the Coal Pile Runoff Pond Retrofit and Gypsum Recycle Pond CCR wastestream reroutes and award equipment contracts for new tank/pumps. Concurrently, apply for Dam Safety Permit and State Water Pollution Control Construction / Operating permit	All pond modification construction is forecasted to be completed within this calendar year.
October 20, 2021	Scheduled	Bid/award pond modification construction contract. Receive Dam Safety Permit, State Water Pollution Control Construction / Operating permits, and General NPDES Permit for Storm Water Discharges from Construction Activities and Stormwater Pollution Prevention Plan.  Complete reroute of CCR wastestreams to effluent tanks and close Gypsum Recycle Pond by removal, complete retrofit of Coal Pile Runoff Pond	Dynegy is projecting that reroute activities for the Gypsum Recycle Pond can be completed, the Coal Pile Runoff Pond retrofit construction can be completed, and the flow of CCR and non-CCR wastestreams to D Basin can cease as of October of 2021.

**2.2 Detailed Schedule to Obtain Alternative Disposal Capacity - § 257.103(f)(1)(iv)(A)(2)**

The required visual timeline representation of the schedule is included in Appendix B of this demonstration and described further in Section 2.3 below.

**2.3 Narrative of Schedule and Visual Timeline - § 257.103(f)(1)(iv)(A)(3)**

The third section for the workplan is a “detailed narrative of the schedule and the timeline discussing all the necessary phases and steps in the workplan, in addition to the overall timeframe that will be required to obtain capacity and cease receipt of waste.” 85 Fed. Reg. at 53,544. As EPA explained in the preamble to the Part A rule, this section of the workplan must discuss “why the length of time for each phase and step is needed, including a discussion of the tasks that occur during the specific stage of obtaining alternative

capacity. It must also discuss the tasks that occur during each of the steps within the phase.” 85 Fed. Reg. at 53,544. In addition, the schedule should “explain why each phase and step shown on the chart must happen in the order it is occurring and include a justification for the overall length of the phase” and the “anticipated worker schedule.” 85 Fed. Reg. at 53,544. EPA notes the overall “discussion of the schedule assists EPA in understanding why the time requested is accurate.” 85 Fed. Reg. at 53,544.

This section of the demonstration is focused on the remaining work necessary to obtain alternate disposal capacity for the CCR and non-CCR wastestreams and complete the modifications to the two CCR surface impoundments (the Gypsum Recycle Pond and Coal Pile Runoff Pond) at Zimmer prior to initiating closure of the D Basin. Based on the estimated durations shown in the schedule in Appendix B, the impoundment modifications will likely only require one construction season for completion. The following paragraphs outline the scope required for the retrofit of each impoundment.

Design and Permitting Activities: Dynegy is in the process of bidding and awarding an engineering contract for design of the retrofit for the Coal Pile Runoff Pond and flow modifications to support closure of the Gypsum Recycle Pond so the area may be repurposed as a non-CCR basin. Dynegy has included four months for the selected engineering firm to prepare the retrofit plan (per § 257.102(k)(2)) and the bid documents following notice to proceed. This is based on typical preparation and review time for the technical documents, lead time for the equipment submittals, and includes Dynegy development of the commercial terms for the construction contract. Once the bid documents are ready to be issued, the construction contract will be bid and awarded. Dynegy has assumed the bid period will be three weeks long and that it will take two weeks to evaluate bids and select the preferred contractor and another four weeks to negotiate the commercial terms for award of the contract. This design phase will be performed concurrently with acquiring the construction/operating permits and the general NPDES permit, dam safety permit modifications (if required), and developing a Stormwater Pollution Prevention Plan, for this project.

Equipment Procurement: Dynegy will procure the new shop-fabricated tank and pump skid(s) necessary to route the magnesium thickener overflow to the Mercury Effluent Treatment System. Based on Burns & McDonnell experience on similar projects, the shop fabricated tank and pumps are expected to have a lead times of 21 and 28 weeks from contract award to delivery, respectively. The specifications will be prepared within one month of selecting the engineering firm, will be bid out over a three-week period, and will be awarded within one month of receiving bids. The design submittals should be received within one month of contract award, allowing the engineering design of the foundations and power supply systems to be completed approximately two months after contract award. The equipment should be onsite in the Summer of 2021 as shown in Appendix B.

Gypsum Recycle Pond Activities: The durations shown on the project schedule are estimates by Burns & McDonnell and are based on an average work schedule of five ten-hour days per week, are subject to delays from periods with significant rain events or from impoundment/CCR dewatering impacts, and are based on the following scope of work which must be performed in the sequence listed below:

- Contractor shall order necessary materials and mobilize to the site. The lead time for the piping materials are shown on the Appendix B schedule and are based on Burns & McDonnell estimates for this scope of work.
- Contractor shall construct the foundation for the new tank and pump skid. This can be completed once the contractor is onsite and the necessary materials have been received. Three weeks were allotted for preparing subgrade, form work, rebar, and pouring this foundation. Burns & McDonnell has assumed that deep foundations and piling will not be required for this equipment.
- Contractor will construct the long runs of HDPE piping for the centrate system effluent and the magnesium thickener effluent. These lines are each approximately 3,300 feet in length and will require fusion of the piping, trenching, and backfill operations. This work is anticipated to require 3 months of effort. It can be started prior to having the tank and pumps in place and available, but not until the initial deliveries of pipe material are completed. The current schedule shows the trenching efforts beginning one month after the pipe material is ordered and two weeks before the final pipe deliveries are completed.
- Contractor will set the tank and pump skid(s) following (1) construction of the foundation and (2) delivery of the equipment.
- Contractor will install the pipe from the current thickener effluent system to the new tank and from the tank to the new pump skids. The Contractor will also install raceway and cable for the new pump and agitator power feeds. These activities are based on one-month durations and are not on the critical path for the project. They cannot be completed until the equipment is set in place.
- Once the tank, pumps, piping, and power systems are installed, the Contractor can start up the new system and divert the CCR wastestreams away from the Gypsum Recycle Pond. The remaining non-CCR wastestreams are intermittent and will continue to be routed to the pond.
- Contractor shall remove the free water and any remaining CCR material and other sediment from the impoundment and haul this material to the Zimmer Landfill.
  - It's estimated approximately 800 cubic yards (CY) of CCR material will be removed from the pond, which should be able to be completed in a single work day with allowance for the pond bottom to be washed down and visually inspected by Dynegey's Consultant to confirm CCR

material has been removed. It was assumed the existing concrete liner (approximately 3,100 square yards) will remain in place.

- Since the impoundment is currently not exceeding a groundwater protection standard, the closure of this impoundment should be complete once the CCR material has been removed (per the standard outlined in § 257.102(c)). The pond footprint will remain and serve as a new non-CCR surface impoundment which will continue to receive intermittent stormwater and low volume wastewater flows.

Coal Pile Runoff Pond Retrofit Activities: The durations shown on the project are estimates by Burns & McDonnell and are based on an average work schedule of five days per week, are subject to delays from periods with significant rain events or from impoundment/CCR dewatering impacts, and are based on the following scope of work which must be performed in the sequence listed below:

- Contractor shall order necessary materials and mobilize to the site. This requires geosynthetic materials as necessary to complete the project scope as well as valves and piping for the water redirection efforts.
- Contractor shall temporarily reroute A, B, and C Basin discharges to D Basin and reroute the D Basin discharge to the Wastewater Pond. This will require the addition of valves and temporary piping to relocate these streams.
- Contractor shall redirect flow from the Mercury Effluent Treatment System to D Basin so that CCR solids from the Coal Pile Runoff Pond may be captured in D Basin during the retrofit activities. Excess water will be pumped to the Wastewater Pond for discharge.
- Contractor shall remove the free water and then remove any CCR material, sediment, and the 3-foot clay liner from the impoundment, and haul and place this material at the Zimmer Landfill.
  - This schedule duration is based on the Contractor removing approximately 24,000 CY of material at 3,000 CY each day and with an allowance of 15% for delays due to weather or other factors. The pond bottom will be visually inspected by Dynegy's Consultant to confirm CCR material and bottom liner have been removed. Five days were included in the schedule for the inspection activities to be performed. Once approved, the subgrade will be prepared for the liner placement.
- Contractor shall install a GCL over the sides and floor of the Coal Pile Runoff Pond and secure it in a perimeter anchor trench. Contractor shall install a 60-mil HDPE geomembrane liner directly over the GCL and secure it in a perimeter anchor trench. This will occur at the same time as the GCL placement, lagging slightly behind it but overlapping. Consequently, these activities are shown on the same timeline in Appendix B.

- This schedule duration is based on the Contractor placing approximately 2.7 acres of material at one acre per day per layer (two layers total) and with an allowance of 15% for delays due to weather or other factors as well as a few days to complete construction quality assurance testing for the geomembrane liner.
- Contractor shall install geotextile fabric over the HDPE geomembrane liner. Again, approximately 2.7 acres of material will be placed at about one acre per day. This work must be completed following completion and inspection of the GCL and HDPE liners. Over the fabric layer, Contractor will install at least 12 inches of crushed rock over the pond bottom (approximately 1,700 CY placed at about 1,000 CY a day) and 15 inches of riprap over the pond slopes (approximately 2,200 CY placed at about 500 CY a day). Again, 15% allowance was included in for delays.
- The Contractor shall pump off stormwater as necessary from the Coal Pile Runoff Pond to D Basin during construction. This is an ongoing activity that will be required following each rain event during the construction period. Consequently, it is not shown on the construction schedule.
- Once the crushed rock and riprap layers are installed and any remaining punch list items are closed out, Dynegy will post the required notification of retrofit completion and resume operation of the Coal Pile Runoff Pond. Dynegy may then initiate closure of the D Basin.

## **2.4 Progress Towards Obtaining Alternative Capacity - § 257.103(f)(1)(iv)(A)(4)**

In the preamble to the final Part A rule, EPA explains that this “section [of the workplan] must discuss all of the steps taken, starting from when the owner or operator initiated the design phase all the way up to the current steps occurring while the workplan is being drafted.” 85 Fed. Reg. at 53,544. The discussion also “must indicate where the facility currently is on the timeline and the processes that are currently being undertaken at the facility to develop alternative capacity.” 85 Fed. Reg. at 53,545.

Dynegy has made progress toward preparing a strategy for creating alternative disposal capacity for the CCR and non-CCR wastestreams at Zimmer. Dynegy has evaluated alternatives and selected a retrofit scenario. The remaining activities are provided in Appendix B and summarized in Table 2-6.

### 3.0 DOCUMENTATION AND CERTIFICATION OF COMPLIANCE

To demonstrate that the criteria in 40 C.F.R. § 257.103(f)(1)(iii) has been met, the following information and submissions are submitted pursuant to 40 C.F.R. § 257.103(f)(1)(iv)(B) to demonstrate that the CCR surface impoundments at Zimmer are in compliance with the CCR Rule.

#### 3.1 Owner's Certification of Compliance - § 257.103(f)(1)(iv)(B)(1)

In accordance with 40 C.F.R. § 257.103(f)(1)(iv)(B)(1), I hereby certify that, based on my inquiry of those persons who are immediately responsible for compliance with environmental regulations for the CCR surface impoundments at Zimmer, the facilities are in compliance with all of the requirements contained in 40 C.F.R. Part 257, Subpart D – Standards for the Disposal of Coal Combustion Residuals in Landfills and Surface Impoundments. Zimmer's CCR compliance website is up-to-date and contains all the necessary documentation and notification postings.

**DYNEGY ZIMMER, LLC**

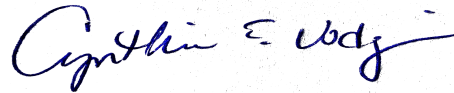

---

Cynthia Vodopivec  
VP - Environmental Health & Safety  
September 28, 2020

#### 3.2 Visual Representation of Hydrogeologic Information - § 257.103(f)(1)(iv)(B)(2)

Consistent with the requirements of § 257.103(f)(1)(iv)(B)(2)(i) – (iii), Dynegy has attached the following items to this demonstration:

- Map(s) of groundwater monitoring well locations in relation to the CCR unit (Attachment C1)
- Well construction diagrams and drilling logs for all groundwater monitoring wells (Attachment C2)
- Maps that characterize the direction of groundwater flow accounting for seasonal variations (Attachment C3)

### **3.3 Groundwater Monitoring Results - § 257.103(f)(1)(iv)(B)(3)**

Tables summarizing constituent concentrations at each groundwater monitoring well through the first 2020 semi-annual monitoring period are included as Attachment C4.

### **3.4 Description of Site Hydrogeology - § 257.103(f)(1)(iv)(B)(4)**

A description of site hydrogeology and stratigraphic cross-sections of the site are included as Attachment C5.

### **3.5 Corrective Measures Assessment - § 257.103(f)(1)(iv)(B)(5)**

Background sampling began at Zimmer in late 2015 and continued for eight consecutive quarters. The first semi-annual detection monitoring samples were collected in November 2017. The first assessment monitoring samples were collected in May 2018. The results, through the first 2020 semi-annual monitoring period, indicate all three CCR surface impoundments at Zimmer are currently in assessment monitoring, with no exceedances of the Appendix IV parameters. Accordingly, an assessment of corrective measures and the associated remedy selection efforts are not currently required at the site.

### **3.6 Remedy Selection Progress Report - § 257.103(f)(1)(iv)(B)(6)**

As noted above, an assessment of corrective measures and the resulting remedy selection efforts are not currently required for the CCR surface impoundments at Zimmer.

### **3.7 Structural Stability Assessment - § 257.103(f)(1)(iv)(B)(7)**

Pursuant to § 257.73(d), the initial structural stability assessment reports for the Coal Pile Runoff Pond, Gypsum Recycle Pond, and D Basin were prepared in October 2016, and are included as Attachment C6. As required for compliance, additional stability assessments will be completed in October 2021.

### **3.8 Safety Factor Assessment - § 257.103(f)(1)(iv)(B)(8)**

Pursuant to § 257.73(e), the initial safety factor assessment reports for the Coal Pile Runoff Pond, Gypsum Recycle Pond, and D Basin were prepared in October 2016, and are included as Attachment C7. As required for compliance, additional safety factor assessments will be completed in October 2021.

## 4.0 CONCLUSION

Based upon the information submitted in this demonstration, the CCR surface impoundments at Zimmer qualify for a site-specific alternative deadline for the initiation of closure as allowed by 40 C.F.R. § 257.103(f)(1).

Therefore, Dynegy requests that EPA approve the demonstration and grant an alternative deadline of October 20, 2021 to retrofit the Coal Pile Runoff Pond, reroute CCR wastestreams away from the Gypsum Recycle Pond to the Mercury Effluent Treatment System, close the Gypsum Recycle Pond and repurpose as a non-CCR basin, and initiate closure of D Basin in accordance with the CCR Rule. As discussed previously, this date is subject to delays from weather during construction or from challenges in CCR material removal and dewatering. Dynegy will update EPA on the project and any potential schedule impacts as part of the semi-annual progress reports required at 40 C.F.R. § 257.103(f)(1)(x), and if a need for a later compliance deadline is determined, Dynegy will seek additional time as described in 40 C.F.R. § 257.103(f)(1)(vii).



**APPENDIX A – SITE PLAN AND WATER BALANCE DIAGRAM**



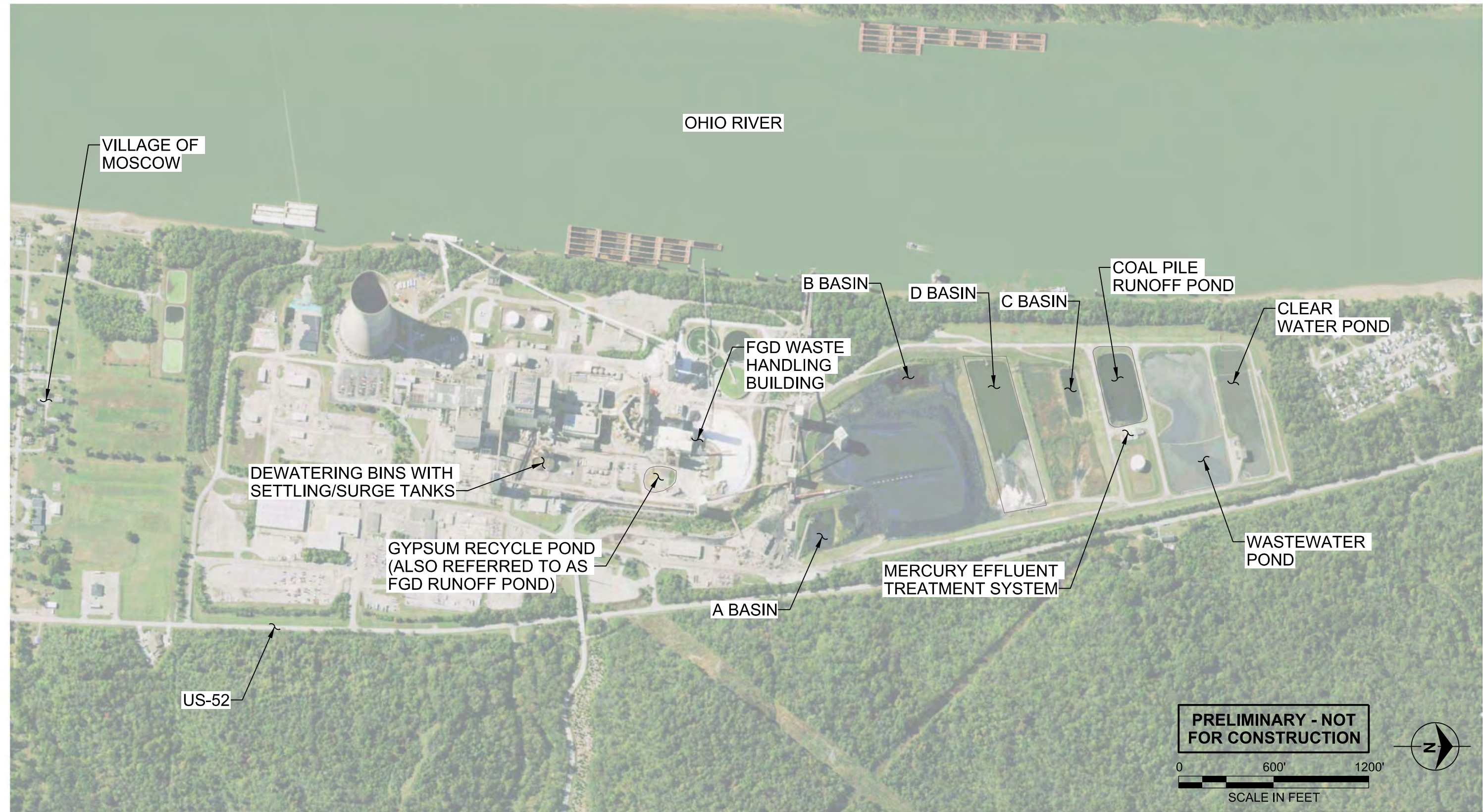

**PRELIMINARY - NOT FOR CONSTRUCTION**

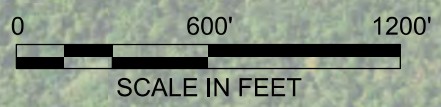

 date 4/17/2020 designed A. MYERS	<b>LUMINANT ZIMMER POWER STATION SITE PLAN</b>	project 122702
		contract -
		dwg <b>FIGURE 1</b>



no.	date	by	ckd	description
A	5/24/17	DKE	KAB	Initial Issue
B	10/13/17	ZSF	AAE	Updated with Flow Data
C	9/24/18	DKE	BDH	Updated logo

- NOTES:**
1. Average flows are based on 30 day average.
  2. Max flows are based on 10 year, 24 hour rain event.
  3. Average and max flows of streams highlighted in grey were updated based on BMcD flow survey data.
  4. Gypsum average daily water flow rate assumes previous value of 566,600 WTPY, at 10% moisture and 340 DPY.
  5. Flow diagram is intended to depict plant typical daily flows and usage. Flow rates shown in diagram are not intended to balance. (Total flow in ≠ Total flow out)

**Ohio River**

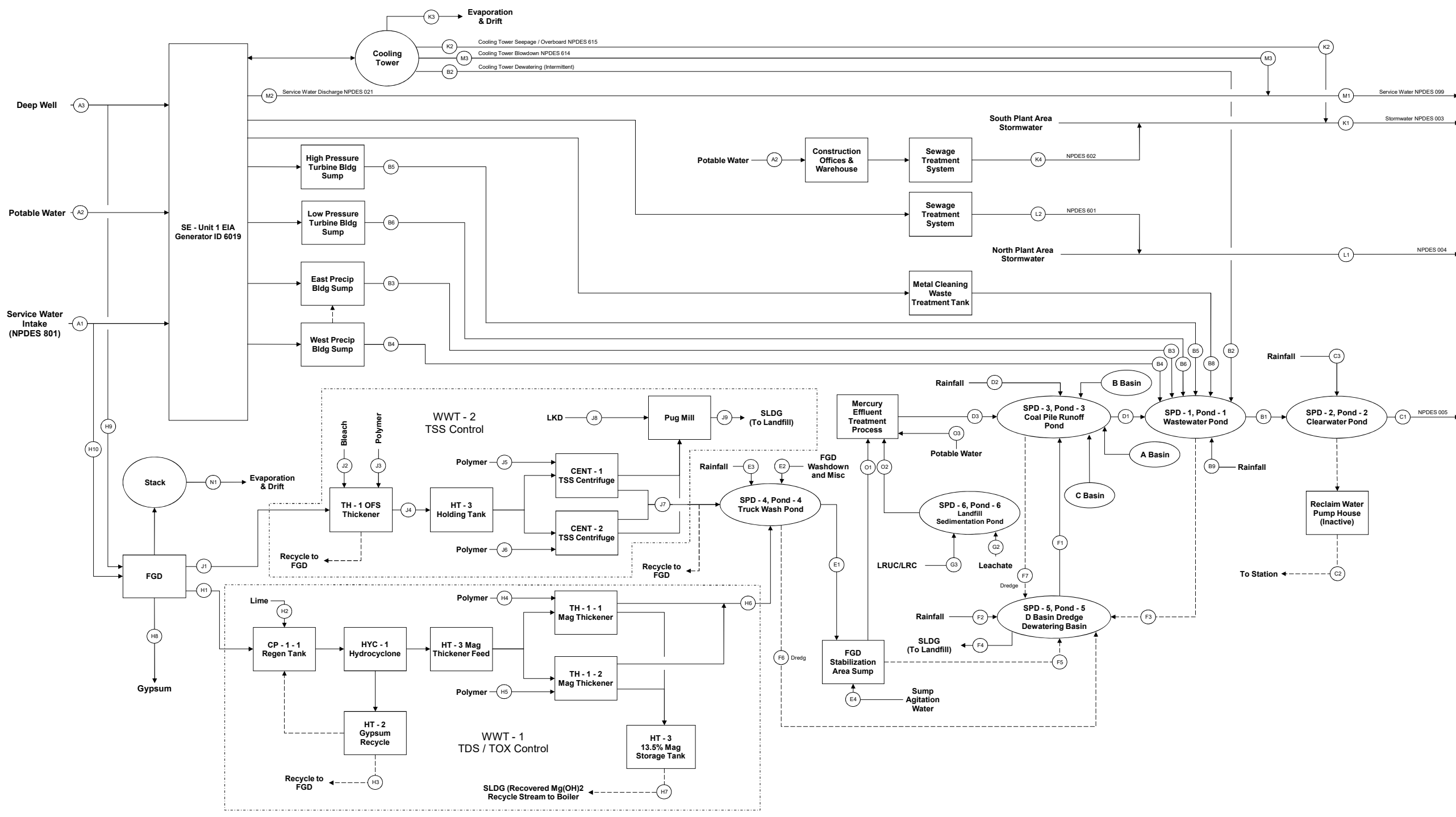

**PRELIMINARY**



date	5/23/2017	detailed	D. Elliott
designed	D. Elliott	checked	K. Bland



**Dynegy  
Zimmer Station  
Plant Water Flow Diagram**

project	99477	contract	
drawing	WMB-01	rev	C
sheet	1	of	1
file		sheet	

**FIGURE 2**

COPYRIGHT © 2018 BY BURNS & McDONNELL ENGINEERING COMPANY, INC.

Flow Label	Block Diagram Name	Station Name	MGD	Flow Data	Flow Label	Block Diagram Name	Station Name	MGD	Flow Data	Flow Label	Block Diagram Name	Station Name	MGD	Flow Data	EPA and Station Abbreviations
A1	NPDES801	Service Water Intake (Ohio River)	36.5	36,500,000 GPD 343 DPY		SPD - 4, Pond - 4	Truck Wash Pond			J1	WWT-2 / SCRBP	Influent - OFS Thickener from Gypsum Clarifier <sup>2</sup>	0.457 / 0.471	457,000 GPD 340 DPY	AHCW - Air Heater Cleaning Water
A2	Potable Water	Tate - Monroe Water Association	0.032 / 0.300	32,000 GPD 365 DPY	E1	Pond - 4 - EFF	Truck Wash Pond to Sump	0.566 / 0.782	566,000 GPD 340 DPY	J2		Bleach - Thickener	0.079	55 GPM 150 DPY	CTB - Cooling Tower Blowdown
A3	Deep Well	Station Well Water	1.85	1,850,000 GPD 365 DPY	E2	FDW	FGD Washdown and Misc.	0.229	160 GPM 340 DPY	J3		Polymer - Thickener		180 LB/DAY 323 DPY	EFF - Effluent
B1	SPD - 1, Pond - 1	Wastewater Pond	4.29 / 13.85	4,293,000 GPD 365 DPY	E3	GPR	Rainfall / Gypsum Pile Runoff	0 / 0.76	0 GPD	J4		Feed Tank - Centrifuge <sup>3</sup>	0.100 / 0.400	100,000 GPD 240 DPY	EVAP - Evaporation
B2	FDW	Sump - East Precipitator <sup>1</sup>	1.44 / 2.41	1,442,000 GPD 340 DPY	F1	Pond - 5 - EFF	D Basin Sump to Coal Pile Runoff	0.09 / 1.95	90,000 GPD 126 DPY	J5		Polymer - Centrifuge		298 LB/DAY 230 DPY	FDW - Floor Drain Wastewater
B3	FDW	Sump - West Precipitator <sup>2</sup>		Not used during testing	F2	CPR	Coal Pile Rainfall	0 / 6.01	0 GPD	J6		Polymer - Centrifuge		298 LB/DAY 230 DPY	GPR - Gypsum Pile Runoff
B4	AHCW/FDW	Sump - HP Turbine <sup>2</sup>	1.72 / 2.93	1,720,000 GPD 340 DPY	F3	SLDG	Dredge Sludge from WW Pond		128,000 WTPY	J7	WWT - 2 - EFF	LKD		350 TPD 240 DPY	GR - General Runoff
B5	IXW/FDW	Sump - LP Turbine (Waste Collect Tank) <sup>2</sup>	0.169 / 1.058	169,000 GPD 340 DPY	F4	SLDG / LANDF	Dewatered Sludge		59,482 WTPY	J8	LANDF	SLDG (To Landfill)		60 TPD 240 DPY	HAUL - Hauled Off Site for Disposal
B6					F5		FGD Sump to Basin			J9		Pug Mill		350 TPD 240 DPY	IXW - Ion Exchange Wastewater
B8	HAUL	Metal Cleaning Waste Tank (Not Used)		Inactive	F6		Dredge Sludge from Truck Wash Pond			J10		Mercury Effluent Treatment Process			LANDF - On Site Landfill
B9	GR	Rainfall	0.03 / 1.02	30,000 GPD 126 DPY	F7		Dredge Sludge from Coal Pile Runoff Pond			J11		FGD Stabilization Area Sump			LEACH - Leachate
C1	SPD - 2, Pond - 2	Clearwater Pond	5.22 / 14.40	5,216,000 GPD	G2	LEACH	Leachate Collection <sup>2</sup>	0.193 / 0.239	193,000 GPD 365 DPY	K1	NPDES 003 / SW/YARDW	Stormwater Outfall - South Plant Area+615+602		34,400 GPD 10 DPY	LKD - Lime Klin Dust
C2		Reclaim Water Pump House		Inactive	G3	LRG / LRUC	Landfill Runoff	0.20016	200,160 GPD 126 DPY	K2	NPDES 615	Cooling Tower Seepage / Overboard		34,400 GPD 10 DPY	LRG - Landfill Runoff - Capped Landfill
C3		Rainfall	0 / 0.55	0 GPD	H1		Wastewater Treatment Systems	0.296 / 0.353	296,000 GPD 340 DPY	K3	EVAP	Cooling Tower Evaporation and Drift	15.5	15,500,000 GPD 340 DPY	LRUC - Landfill Runoff - Uncapped Landfill
D1	SPD - 3, Pond - 3	Coal Pile Runoff Pond			H2	WWT - 1 / SCRBP	Influent - Regen Tank from CRW Bleed <sup>2</sup>	0.076 / 0.096	76,000 GPD 340 DPY	K4	NPDES 602	Sanitary Construction Offices		400 GPD 365 DPY	MGD - Million Gallons per Day
D2	Pond - 3 - EFF	Gravity Flow to Wastewater Pond	0.934	934,000 GPD 365 DPY	H3	RECVC - Gypsum	Recovered Gypsum	0.048	33 GPM 340 DPY	L1	NPDES 004 / SW/YARDW	Stormwater Outfall - Main Plant Area+601	0.002	2,080 GPD 365 DPY	MGDH2 - Magnesium Hydroxide
D3		Rainfall (Pond Area)	0.00 / 0.31	0 GPD	H4		Polymer - Mag Thickener	0.432 GPD 340 DPY		L2	NPDES 601	Sanitary Main Plant	0.002	2,080 GPD 365 DPY	GFS - Inerts
		Mercury Treatment System to CPR Pond	0.844	844,000 GPD 365 DPY	H5		Polymer - Mag Thickener	0.432 GPD 340 DPY		M1	NPDES 099 / SW	Service Water Outfall Includes NPDES 021, 614	15.5	15,500,000 GPD 343 DPY	RECVC - Recycle Flow
					H6	WWT - 1 - EFF	Effluent from Mag Thickener Overflow <sup>3</sup>	0.262 / 0.336	262,000 GPD 340 DPY	M2	NPDES 021	Service Water Discharge	12.1	12,100,000 GPD 343 DPY	SCRBP - FGD Scrubber Purge
					H7	RECVC - SLDG - MGOH2	Sludge from Mag Thickener Underflow	0.360	42 GPM 340 DPY	M3	NPDES 614 / CTB	Cooling Tower Blowdown	3.37	3,300 GPM 17 HPD 270 DPY	SLDG - Sludge
					H8	Gypsum	Gypsum (Total Produced) <sup>2</sup>	-	566,600 WTPY	M4	NPDES 625	Reclaim Water		Inactive	SW - Discharge to Surface Water
					H9		Gypsum Cake Wash and Pump Seal Water	0.360	250 GPM 340 DPY	O1		FGD Sump to Mercury Treatment System <sup>3</sup>	0.566 / 0.782	566,000 GPD 340 DPY	WTPY - Wet Tons per Year
					H10		FGD Makeup	5.303	1,940 GPM 340 DPY	O2		Landfill Sump to Mercury Treatment System <sup>3</sup>	0.271 / 0.967	271,000 GPD 126 DPY	YARDW - Yard Drain Wastewater

**APPENDIX B – SCHEDULE**

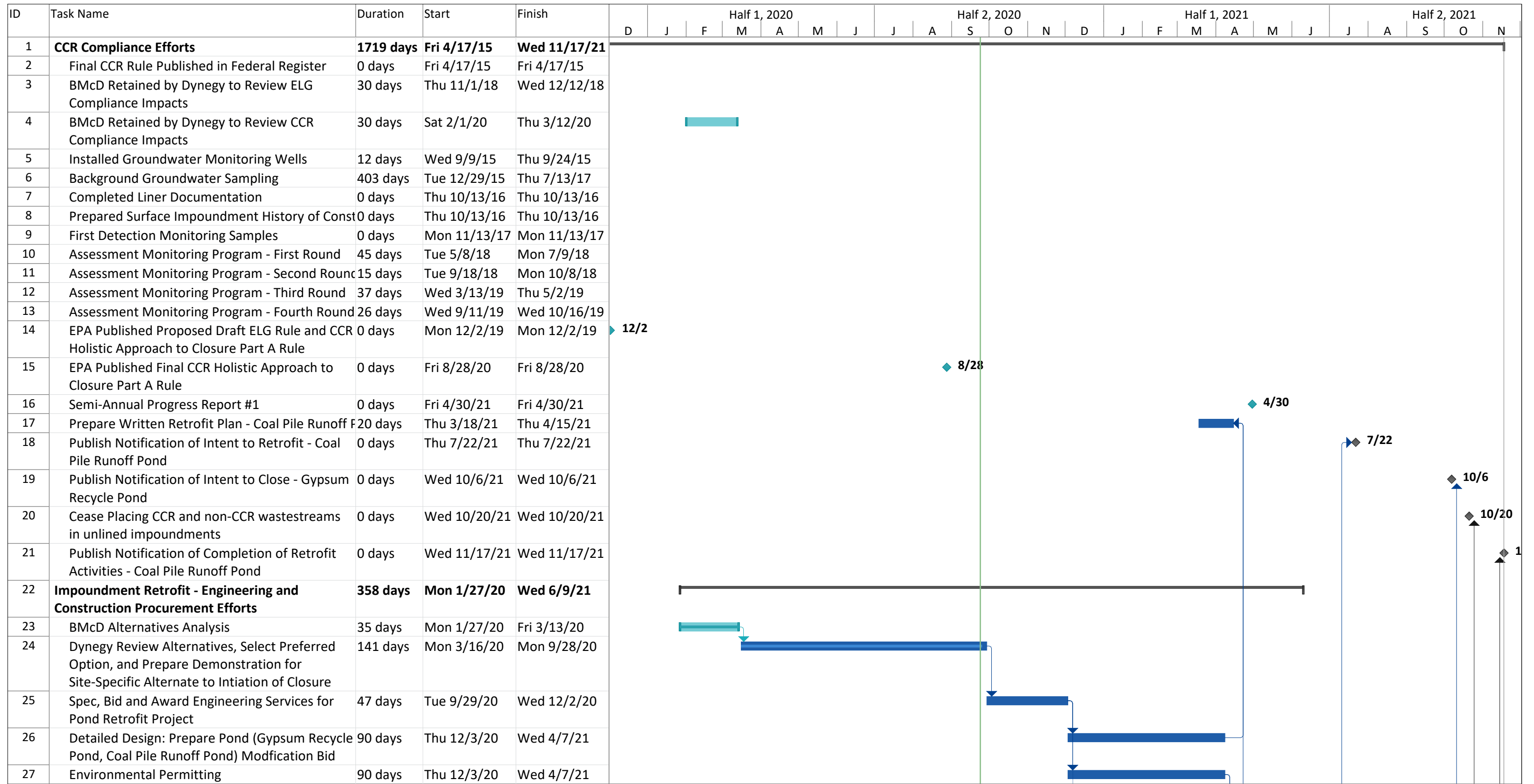

Project: Zimmer CCR Surface Impoundment Extension Demonstration Date: Thu 9/24/20	Task		External Tasks		Manual Task		Finish-only	
	Split		External Milestone		Duration-only		Deadline	
	Milestone		Inactive Task		Manual Summary Rollup		Progress	
	Summary		Inactive Milestone		Manual Summary		Manual Progress	
	Project Summary		Inactive Summary		Start-only			





## **APPENDIX C – COMPLIANCE DOCUMENTS**

**APPENDIX C1 – MAP OF GROUNDWATER MONITORING WELL LOCATIONS**





Service Layer Credits: USGS The National Map: Imagery

-  UPGRADIENT MONITORING WELL LOCATION
-  DOWNGRADIENT MONITORING WELL LOCATION
-  CCR MONITORED UNIT

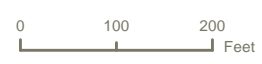

**MONITORING WELL LOCATION MAP**  
**ZIMMER COAL PILE RUNOFF POND**  
**UNIT ID:125**

**2019 ANNUAL GROUNDWATER MONITORING AND CORRECTIVE ACTION REPORT**  
 VISTRA CCR RULE GROUNDWATER MONITORING  
 ZIMMER POWER STATION  
 MOSCOW, OHIO



**FIGURE 1**

O'BRIEN & GERE ENGINEERS, INC.  
A RAMBOLL COMPANY







-  UPGRADIENT MONITORING WELL LOCATION
-  DOWNGRADIENT MONITORING WELL LOCATION
-  CCR MONITORED UNIT



**MONITORING WELL LOCATION MAP  
ZIMMER GYPSUM RECYCLING POND  
UNIT ID:124**

**2019 ANNUAL GROUNDWATER MONITORING AND CORRECTIVE ACTION REPORT**  
VISTRA CCR RULE GROUNDWATER MONITORING  
ZIMMER POWER STATION  
MOSCOW, OHIO

**FIGURE 1**

O'BRIEN & GERE ENGINEERS, INC.  
A RAMBOLL COMPANY







- UPGRADIENT MONITORING WELL LOCATION
- DOWNGRADIENT MONITORING WELL LOCATION
- CCR MONITORED UNIT



**MONITORING WELL LOCATION MAP  
ZIMMER D BASIN  
UNIT ID:121**

**2019 ANNUAL GROUNDWATER MONITORING AND CORRECTIVE ACTION REPORT**  
VISTRA CCR RULE GROUNDWATER MONITORING  
ZIMMER POWER STATION  
MOSCOW, OHIO

**FIGURE 1**

O'BRIEN & GERE ENGINEERS, INC.  
A RAMBOLL COMPANY





**APPENDIX C2 – WELL CONSTRUCTION DIAGRAMS AND DRILLING LOGS**



AMERICAN ELECTRIC POWER SERVICE CORPORATION  
AEP CIVIL ENGINEERING LABORATORY Renamed MW-1

Job No. \_\_\_\_\_  
COMPANY \_\_\_\_\_  
PROJECT \_\_\_\_\_  
COORDINATES \_\_\_\_\_

LOG OF BORING

BORING No. 2117 DATE \_\_\_\_\_ SHEET 2 OF \_\_\_\_\_  
TYPE OF SAMPLES: SPT \_\_\_\_\_ 3" TUBE \_\_\_\_\_ CORE \_\_\_\_\_  
CASING USED \_\_\_\_\_ SIZE \_\_\_\_\_ DRILLING MUD USED \_\_\_\_\_  
BORING BEGUN \_\_\_\_\_ BORING COMPLETED \_\_\_\_\_  
GROUND ELEVATION \_\_\_\_\_ REFERRED TO \_\_\_\_\_ DATUM \_\_\_\_\_  
FIELD PARTY \_\_\_\_\_ RIG \_\_\_\_\_

LOCATION OF BORING:	
WATER LEVEL	
TIME	
DATE	

SAMPLE NUMBER	SAMPLE DEPTH IN FEET		STANDARD PENETRATION RESISTANCE BLOW / 6"			TOTAL LENGTH RECOVERY	RQD %	DEPTH IN FEET	GRAPH LOG	USCS	SOIL / ROCK IDENTIFICATION	DRILLER'S NOTES
	FROM	TO										
								20				
5	22.5	24.0	2	3	4	18"					top 9" Clay - yellowish Br - moist to wet - med to low plasticity	
											CL	
											bottom 9" Clay - Gray - wet - med to low plasticity	
											CL	
6	27.5	29.0	2	3	3	18"					Clay - Gray - wet - med to low plasticity	
											CL	
								30				
7	32.5	34.0	1	2	3	18"					SAME AS 6	
8	37.5	39.0	20	26	12	16"					SAND + GRAVEL - GRAY - BR - SATURATED - QUARTZ - ROUNDED 1/2" MAX SIZE w/ FINE S	
											GM	
								40				
6" x 3.25 HSA HW CASING ADVANCER 4" NQ CORE ROCK												
NW CASING 3"			SW CASING 6"									
RECORDER _____												











AMERICAN ELECTRIC POWER SERVICE CORPORATION  
AEP CIVIL ENGINEERING LABORATORY Renamed MW-3S  
LOG OF BORING

JOB No. \_\_\_\_\_  
COMPANY \_\_\_\_\_  
PROJECT \_\_\_\_\_  
COORDINATES \_\_\_\_\_

BORING No. 2-119 DATE \_\_\_\_\_ SHEET 2 OF 5  
TYPE OF SAMPLES: SPT \_\_\_\_\_ 3" TUBE \_\_\_\_\_ CORE \_\_\_\_\_  
CASING USED \_\_\_\_\_ SIZE \_\_\_\_\_ DRILLING MUO USED \_\_\_\_\_  
BORING BEGUN \_\_\_\_\_ BORING COMPLETED \_\_\_\_\_  
GROUND ELEVATION \_\_\_\_\_ REFERRED TO \_\_\_\_\_ DATUM \_\_\_\_\_  
FIELD PARTY \_\_\_\_\_ RIG \_\_\_\_\_

LOCATION OF BORING:	
WATER LEVEL	
TIME	
DATE	

SAMPLE NUMBER	SAMPLE DEPTH IN FEET		STANDARD PENETRATION RESISTANCE BLOW / 6"			TOTAL LENGTH RECOVERY	RQD %	DEPTH IN FEET	GRAPH LOG	U S C S	SOIL / ROCK IDENTIFICATION	DRILLER'S NOTES
	FROM	TO										
								20				
5	22.5	24.0	3	5	7	16"					CLAY - multi-color Bas - moist med. to low plasticity	
											CL	
6	27.5	29.0	4	5	7	16"					Same as 5	
								30				
7	32.5	34.0	2	4	5	6"					Sandy clay - multi-color Bas moist w/ Dr. Bas. Sand lens	
											CL	
8	37.5	39.0	1	2	3	16"					Sandy clay - Gray - moist to wet w/ v. Fine grain sand lens	
											CL	
								40				
6" x 3.25 HSA HW CASING ADVANCER 4" NQ CORE ROCK												
NW CASING		3"										
SW CASING		6"										
RECORDER _____												

AMERICAN ELECTRIC POWER SERVICE CORPORATION  
AEP CIVIL ENGINEERING LABORATORY Renamed MW-3S  
LOG OF BORING

JOB NO. \_\_\_\_\_  
COMPANY \_\_\_\_\_  
PROJECT \_\_\_\_\_  
COORDINATES \_\_\_\_\_

BORING No. 2119 DATE \_\_\_\_\_ SHEET 3 OF 5  
TYPE OF SAMPLES: SPT \_\_\_\_\_ 3" TUBE \_\_\_\_\_ CORE \_\_\_\_\_  
CASING USED \_\_\_\_\_ SIZE \_\_\_\_\_ DRILLING MUD USED \_\_\_\_\_  
BORING BEGUN \_\_\_\_\_ BORING COMPLETED \_\_\_\_\_  
GROUND ELEVATION \_\_\_\_\_ REFERRED TO \_\_\_\_\_ DATUM \_\_\_\_\_  
FIELD PARTY \_\_\_\_\_ RIG \_\_\_\_\_

LOCATION OF BORING:	
WATER LEVEL	
TIME	
DATE	

SAMPLE NUMBER	SAMPLE DEPTH IN FEET		STANDARD PENETRATION RESISTANCE BLOW / 6"			TOTAL LENGTH RECOVERY %	RQD %	DEPTH IN FEET	GRAPH LOG	USCS	SOIL / ROCK IDENTIFICATION	DRILLER'S NOTES
	FROM	TO										
								40				
9	42.5	44.0	2	2	3	16"				SC	CLAYEY SAND - GRAY SATURATED w/ ORGANIC MATERIAL (WOOD) MIXTURE	
10	47.5	49.0	1	1	13	16"				SC	SAND + GRAVEL - BR - SATURATED QUARTZ - 1/2" MAX SIZE - w/ FINES	
								50				
11	52.5	54.0	6	5	10	0						
12	57.5	59.0	6	7	9	8"				SP	SAND - BR - QUARTZ - SATURATED TRACE OF FINE GRAVEL	
								60				
6" x 3.25 HSA HW CASING ADVANCER 4" NQ CORE ROCK												
NW CASING 3" SW CASING 6"												
											RECORDER _____	

AMERICAN ELECTRIC POWER SERVICE CORPORATION  
AEP CIVIL ENGINEERING LABORATORY Renamed MW-3S

JOB No. \_\_\_\_\_  
COMPANY \_\_\_\_\_  
PROJECT \_\_\_\_\_  
COORDINATES \_\_\_\_\_

LOG OF BORING

BORING No. 7-119 DATE \_\_\_\_\_ SHEET 7 OF 8  
TYPE OF SAMPLES: SPT \_\_\_\_\_ 3" TUBE \_\_\_\_\_ CORE \_\_\_\_\_  
CASING USED \_\_\_\_\_ SIZE \_\_\_\_\_ DRILLING MUD USED \_\_\_\_\_  
BORING BEGUN \_\_\_\_\_ BORING COMPLETED \_\_\_\_\_  
GROUND ELEVATION \_\_\_\_\_ REFERRED TO \_\_\_\_\_ DATUM \_\_\_\_\_  
FIELD PARTY \_\_\_\_\_ RIG \_\_\_\_\_

LOCATION OF BORING:	
WATER LEVEL	
TIME	
DATE	

SAMPLE NUMBER	SAMPLE DEPTH IN FEET		STANDARD PENETRATION RESISTANCE			TOTAL LENGTH RECOVERY	RQD %	DEPTH IN FEET	GRAPH LOG	USCS	SOIL / ROCK IDENTIFICATION	DRILLER'S NOTES
	FROM	TO	BLOW / 6"									
								60				
13	62.5	64.0	9	13	19	16"					Sand - Br. SATURATED med to Fine GRAIN - moderate REACTION TO HCL	
										SP		
14	67.5	69.0	14	22	17	6"					1 GRAVEL Sand - Br. SATURATED 100% Fine GRAIN STRONG REACTION TO HCL	
								70				
										SP		
15	72.5	74.0	13	14	14	12"					SAME AS 14	
16	77.5	79.0	17	24	22	14"					SAME AS 14 GRAY	
								80				
6" x 3.25 HSA												
HW CASING ADVANCER 4"												
NQ CORE ROCK												
NW CASING 3"												
SW CASING 6"												
										RECORDER		





**Project: Dynegy**  
**Project Location: Zimmer Station**  
**Project Number: 60442412**

**Monitoring Well  
 MW-16**  
 Sheet 1 of 2

Date(s) Drilled	8/2/16 - 8/3/16	Logged By	J. Alten	Checked By	Mike Wagner
Drilling Method	Rotosonic	Drilling Contractor	Frontz Drilling	Total Depth of Borehole	70.0 feet bgs
Date of Groundwater Measurement	8/9/16	Sampler Type	Sonic Sleeve	Surface Elevation	509.19 feet, msl
Depth to Groundwater	55.65 ft bgs	Seal Material	Hydrated 3/8-inch Bentonite Chips	Top of PVC Elevation	511.66 feet, msl
Diameter of Hole (inches)	6.0	Diameter of Well (inches)	2	Type of Well Casing	Schedule 40 PVC
Type of Sand Pack	#5 Silica Sand	Well Completion at Ground Surface	Riser, With locking cap and protective casing.		
Comments					

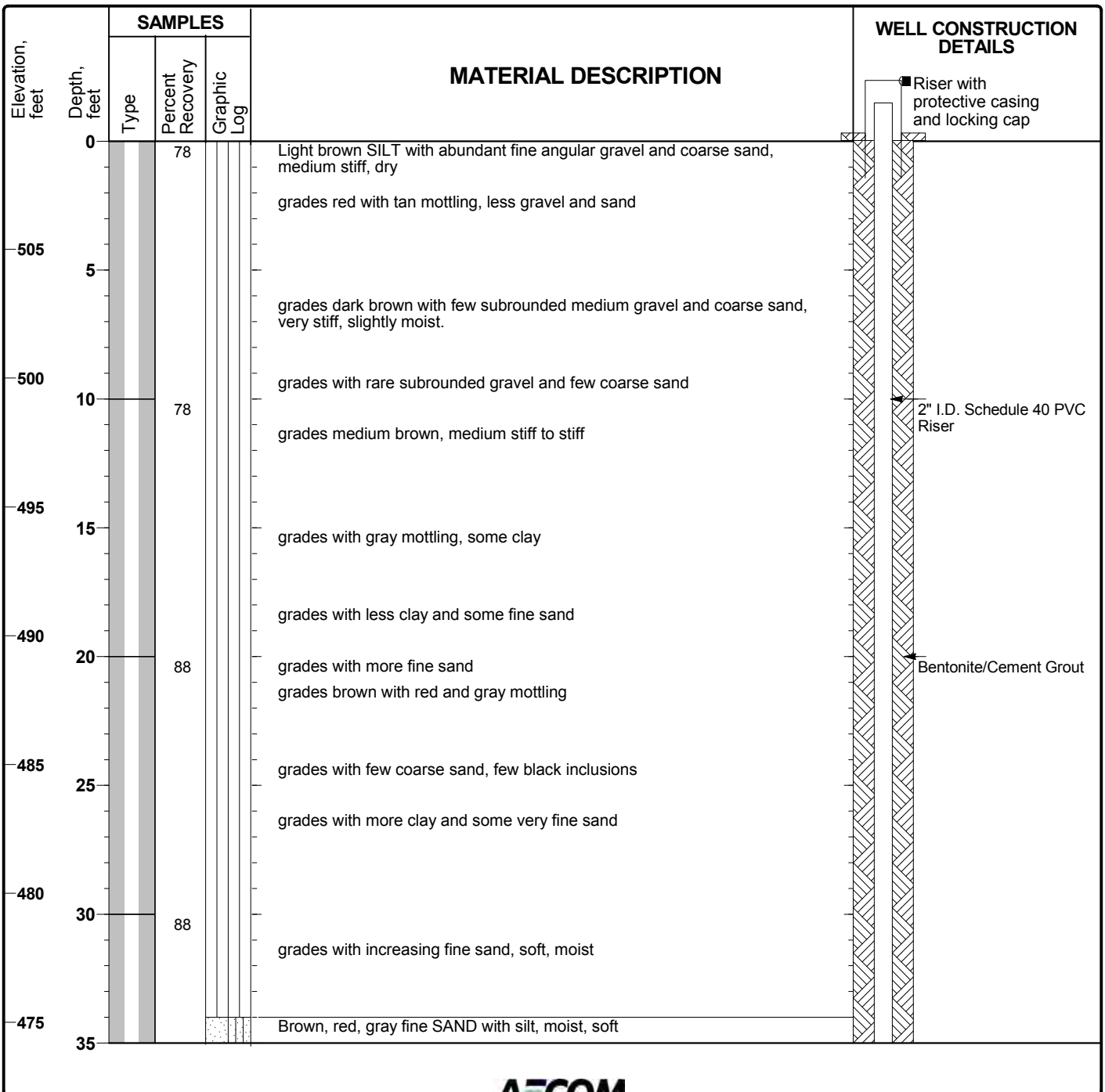

Project: **Dynergy**  
 Project Location: **Zimmer Station**  
 Project Number: **60442412**

**Monitoring Well  
 MW-16**  
 Sheet 2 of 2

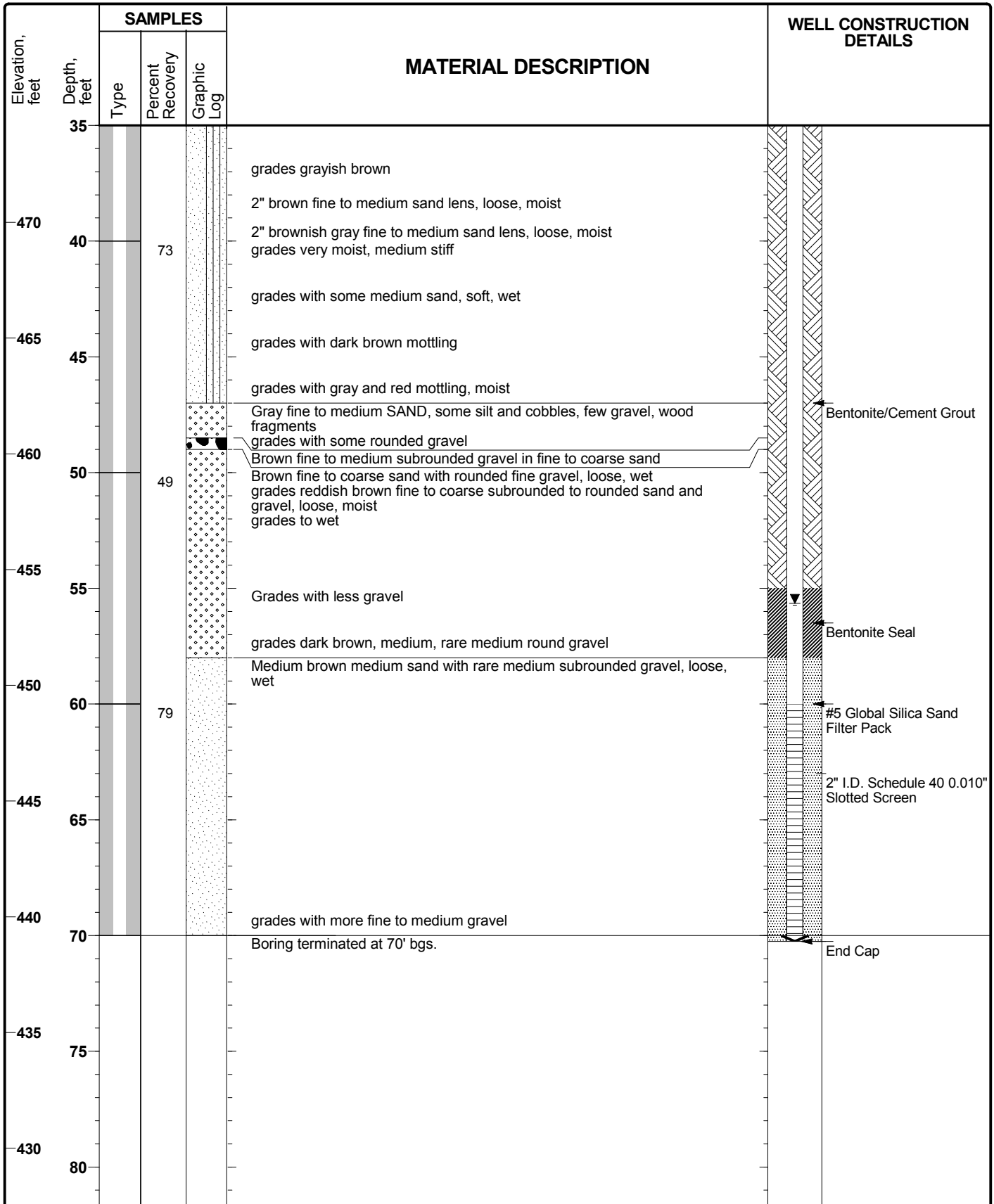

DYNEGY ZIMMER ZIMMER STATION CCR WELLS.GPJ 11/23/16



**Project: Dynegy**  
**Project Location: Zimmer Station**  
**Project Number: 60442412**

**Monitoring Well**  
**MW-17**  
 Sheet 1 of 2

Date(s) Drilled	8/3/16	Logged By	J. Alten	Checked By	Mike Wagner
Drilling Method	Rotosonic	Drilling Contractor	Frontz Drilling	Total Depth of Borehole	70.0 feet bgs
Date of Groundwater Measurement	8/9/16	Sampler Type	Sonic Sleeve	Surface Elevation	508.83 feet, msl
Depth to Groundwater	55.22 ft bgs	Seal Material	Hydrated 3/8-inch Bentonite Chips	Top of PVC Elevation	511.25 feet, msl
Diameter of Hole (inches)	6.0	Diameter of Well (inches)	2	Type of Well Casing	Schedule 40 PVC
Type of Sand Pack	#5 Silica Sand	Well Completion at Ground Surface	Riser, With locking cap and protective casing.		
Comments					

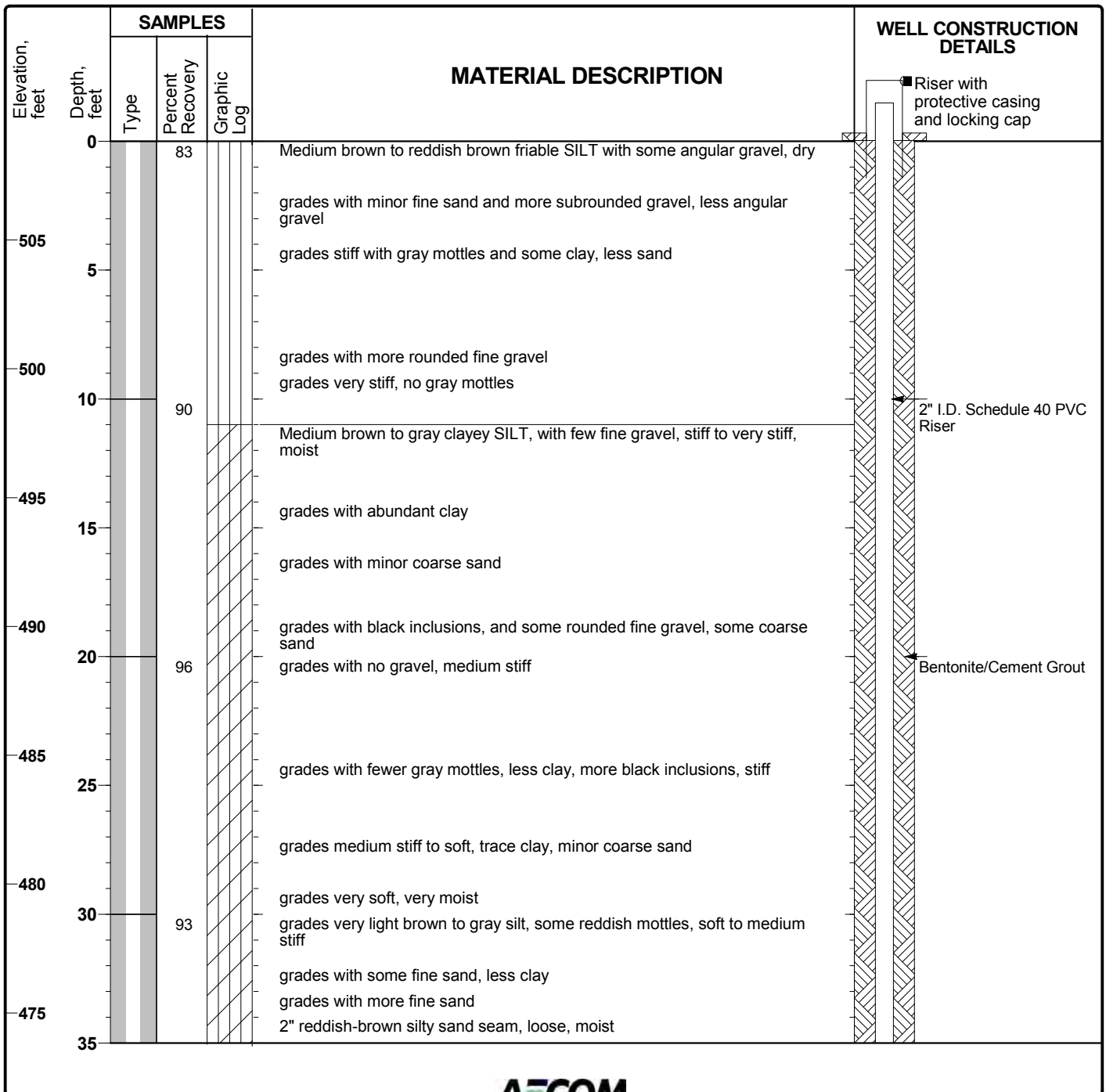

DYNEGY ZIMMER ZIMMER STATION CCR WELLS.GPJ 11/23/16

Project: Dynegy  
 Project Location: Zimmer Station  
 Project Number: 60442412

**Monitoring Well  
 MW-17**  
 Sheet 2 of 2

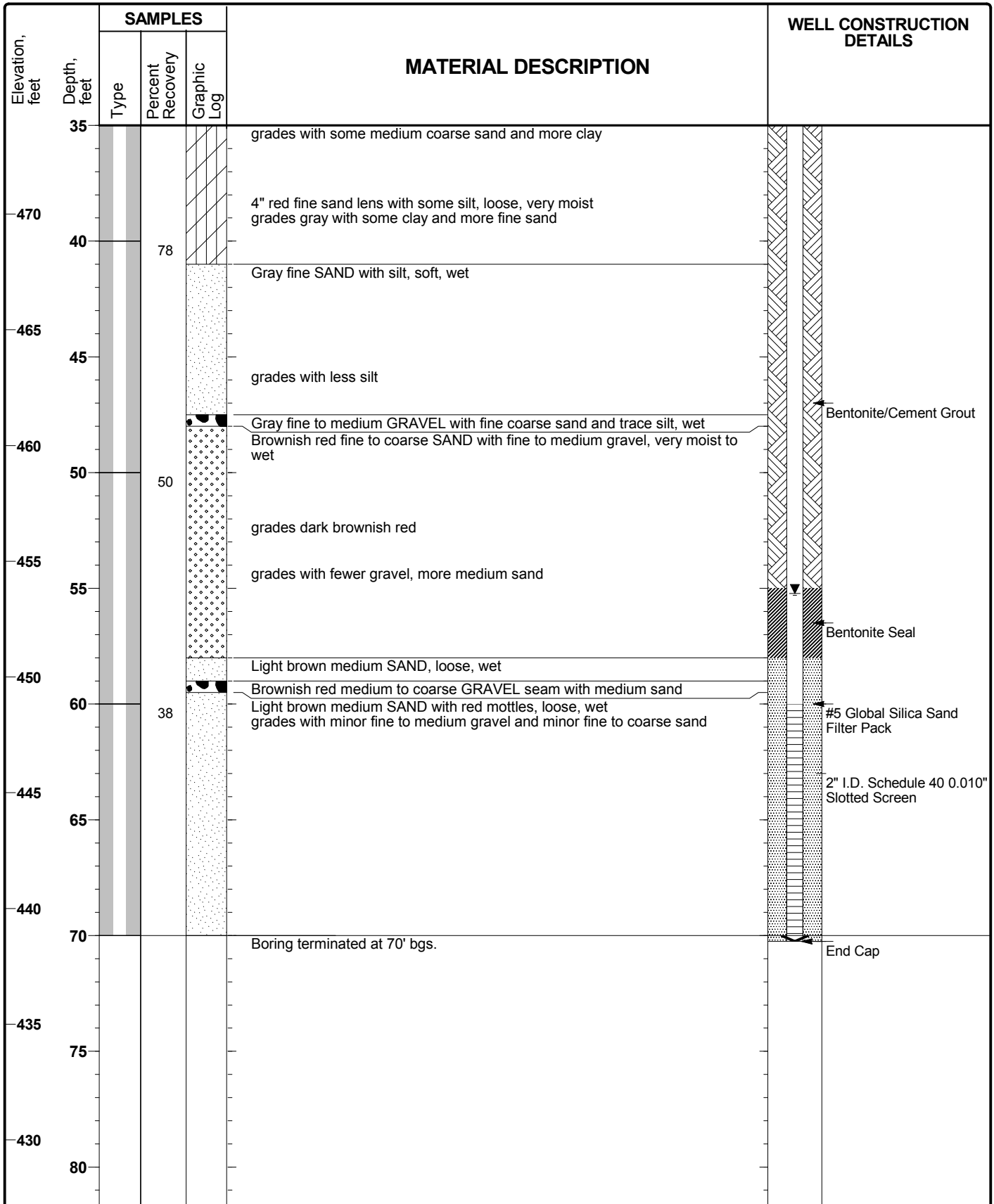

DYNEGY ZIMMER ZIMMER STATION CCR WELLS.GPJ 11/23/16

**Project: Dynegy**  
**Project Location: Zimmer Station**  
**Project Number: 60442412**

**Monitoring Well  
 MW-18**  
 Sheet 1 of 2

Date(s) Drilled	8/4/16	Logged By	J. Alten	Checked By	Mike Wagner
Drilling Method	Rotosonic	Drilling Contractor	Frontz Drilling	Total Depth of Borehole	70.0 feet bgs
Date of Groundwater Measurement	8/9/16	Sampler Type	Sonic Sleeve	Surface Elevation	509.22 feet, msl
Depth to Groundwater	55.59 ft bgs	Seal Material	Hydrated 3/8-inch Bentonite Chips	Top of PVC Elevation	511.63 feet, msl
Diameter of Hole (inches)	6.0	Diameter of Well (inches)	2	Type of Well Casing	Schedule 40 PVC
Type of Sand Pack	#5 Silica Sand	Well Completion at Ground Surface	Riser, With locking cap and protective casing.		
Comments					

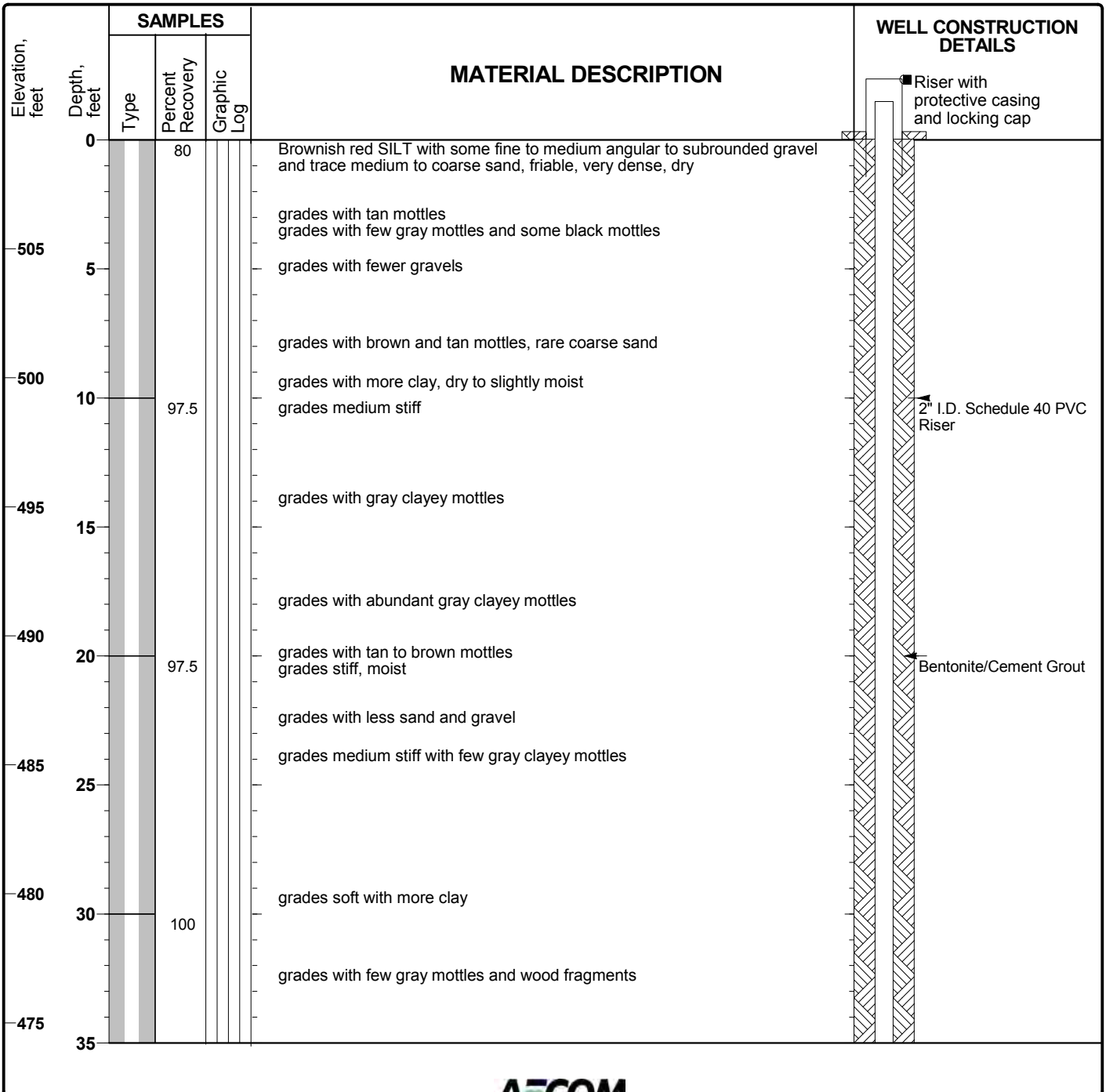

DYNEGY ZIMMER ZIMMER STATION CCR WELLS.GPJ 11/23/16

Project: **Dynergy**  
 Project Location: **Zimmer Station**  
 Project Number: **60442412**

**Monitoring Well  
 MW-18**  
 Sheet 2 of 2

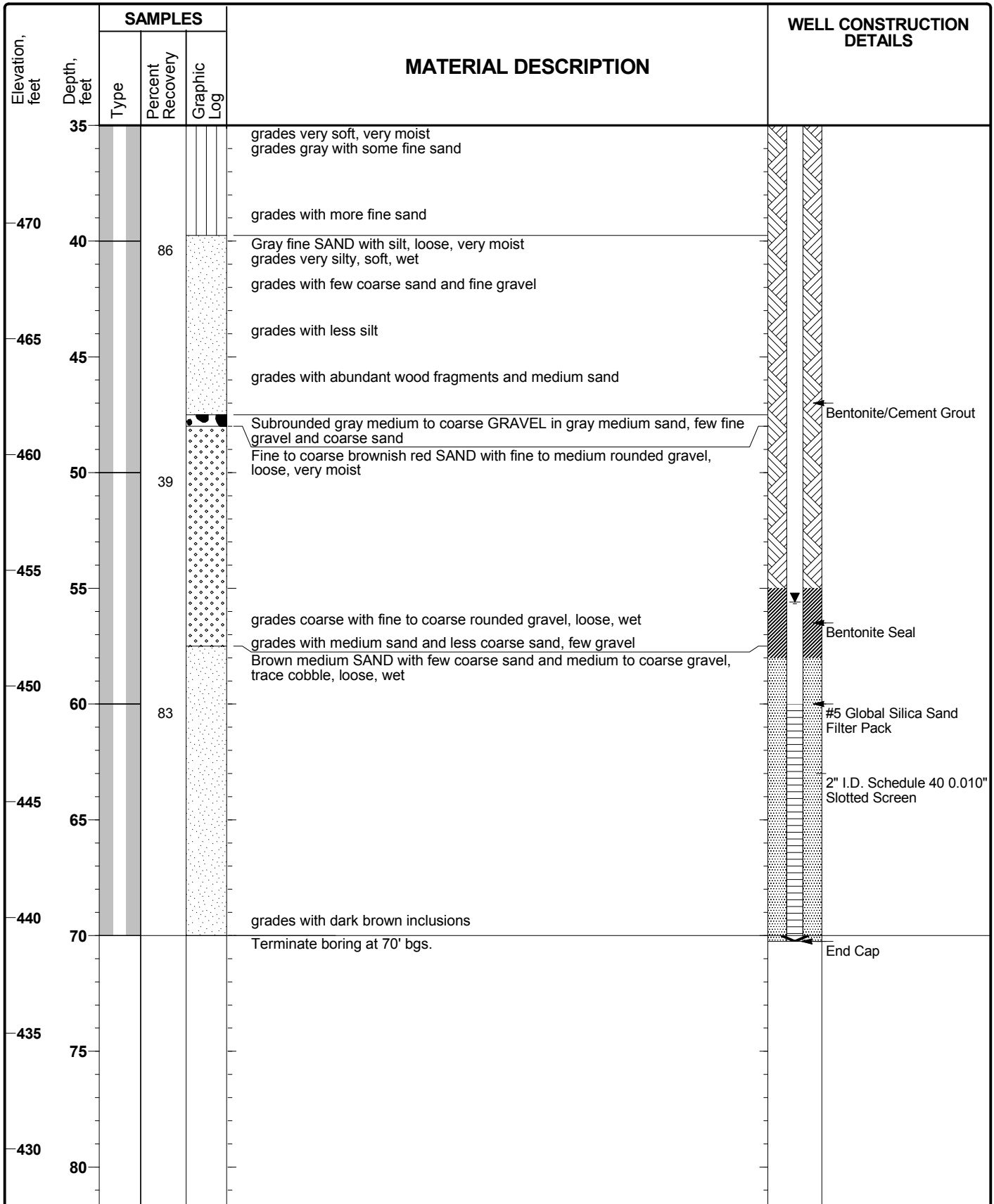

DYNERGY ZIMMER ZIMMER STATION CCR WELLS.GPJ 11/23/16

JOB NO. \_\_\_\_\_  
 COMPANY Zimmer Plant  
 PROJECT \_\_\_\_\_  
 COORDINATES N-5940 W-520  
 DATE 5/2/89 TIME \_\_\_\_\_

**WELL CONSTRUCTION  
 SUMMARY ELEVATIONS  
 (FLNGVD)**

WELL No. 1  
 REF. DATUM PT. 511.8  
 Renamed MW-1  
 GRADE 509.9

1. GROUT SEAL Volclay Group  
509.9 to 470.9
2. BENTONITE SEAL
3. SCREEN 20' x 2" x .02 PVC
4. GRAVEL PACK natural sand
5. N. A.
6. RISER PIPE 2" PVC

Water level 470.5  
 5/2/89

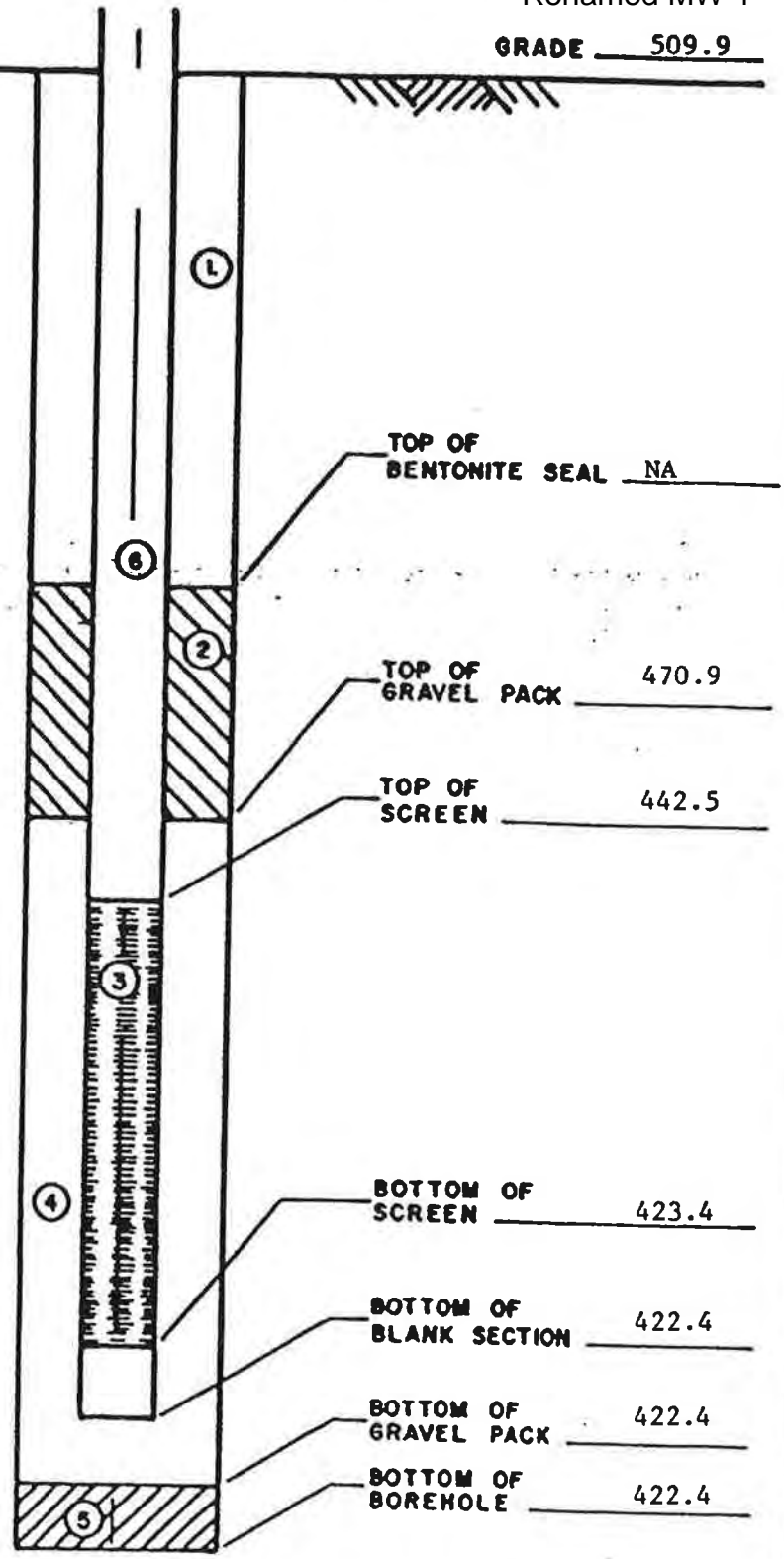

GEOTECHNICAL ENGINEERING SECTION CIVIL DESIGN STANDARD		REVISION		OBSERVATION WELL	
APPROVED	DR.	CH.	_____	_____	
AMERICAN ELECTRIC POWER SVC. CORP.				CDS-04	SH.

COMPANY Zimmer Plant

PROJECT \_\_\_\_\_

COORDINATES N-5710 W-1400

DATE 5/4/89 TIME \_\_\_\_\_

**SUMMARY ELEVATIONS  
(F.L. NGVD)**

WELL No. 3S

REF. DATUM PT. 511.9

Renamed MW-3S

GRADE 509.9

- 1. GROUT SEAL Volclay Grout  
509.9 to 464.9
- 2. BENTONITE SEAL
- 3. SCREEN 20' x 2" x .02 PVC
- 4. GRAVEL PACK natural sand
- 5. N. A.
- 6. RISER PIPE 2" PVC

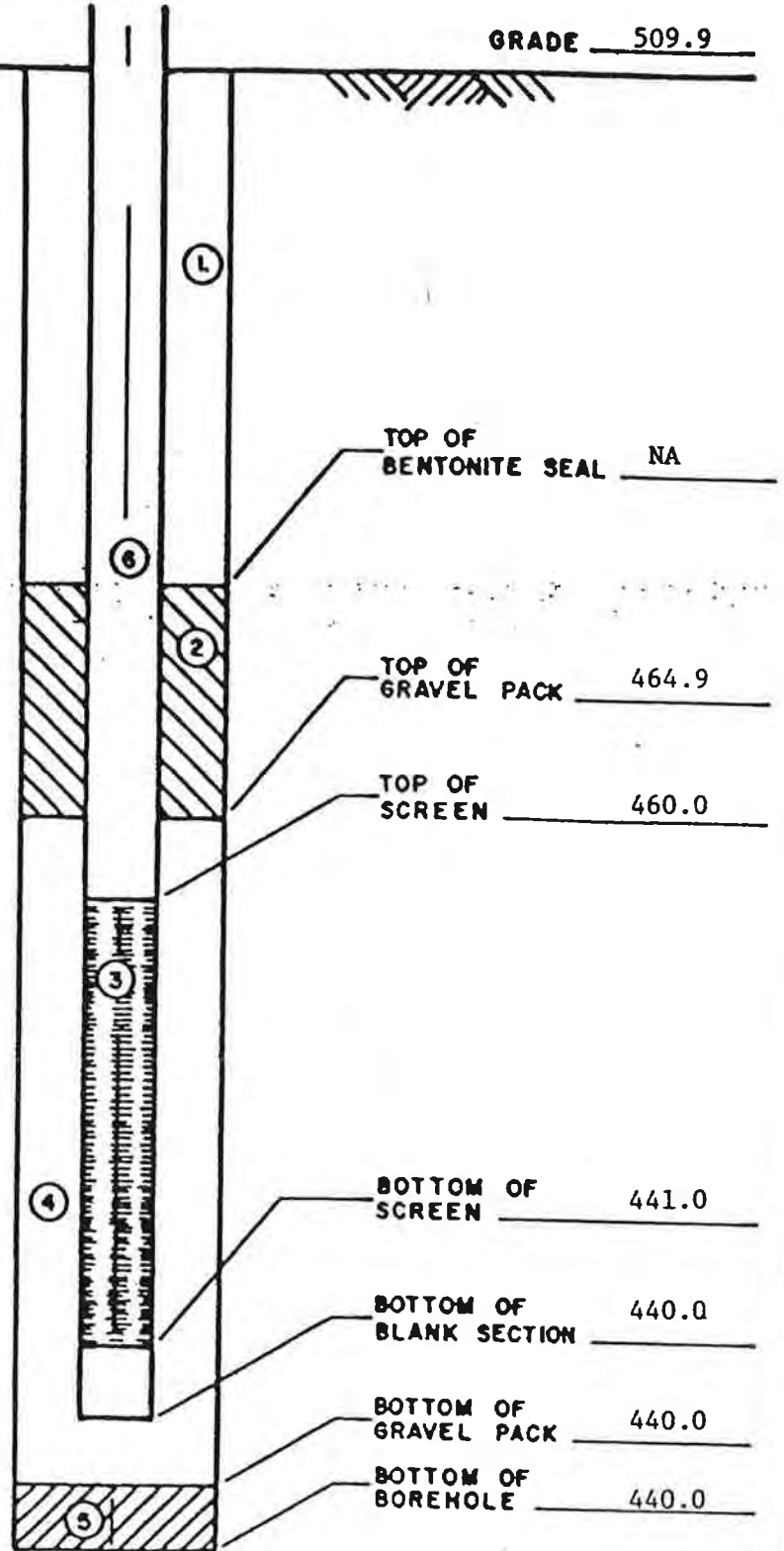

GEOTECHNICAL ENGINEERING SECTION		REVISION		OBSERVATION WELL	
CIVIL DESIGN STANDARD					
APPROVED	DR.	CHL			
AMERICAN ELECTRIC POWER SVC. CORP.				CDS-04	SH.

**Project: Dynegy**  
**Project Location: Zimmer Station**  
**Project Number: 60442412**

**Monitoring Well**  
**MW-7A**  
 Sheet 1 of 2

Date(s) Drilled	12/1/15	Logged By	Becky Smolenski	Checked By	Mike Wagner
Drilling Method	Rotosonic	Drilling Contractor	Frontz Drilling	Total Depth of Borehole	64.0 feet
Date of Groundwater Measurement	12/18/15	Sampler Type	Sonic Sleeve	Surface Elevation	509.53 feet, msl
Depth to Groundwater	54.32 ft bgs	Seal Material	Hydrated 3/8-inch Bentonite Chips	Top of PVC Elevation	511.79 feet, msl
Diameter of Hole (inches)	6.0	Diameter of Well (inches)	2	Type of Well Casing	Schedule 40 PVC
Type of Sand Pack	#5 Silica Sand	Well Completion at Ground Surface	Riser, With locking cap and protective casing.		
Comments					

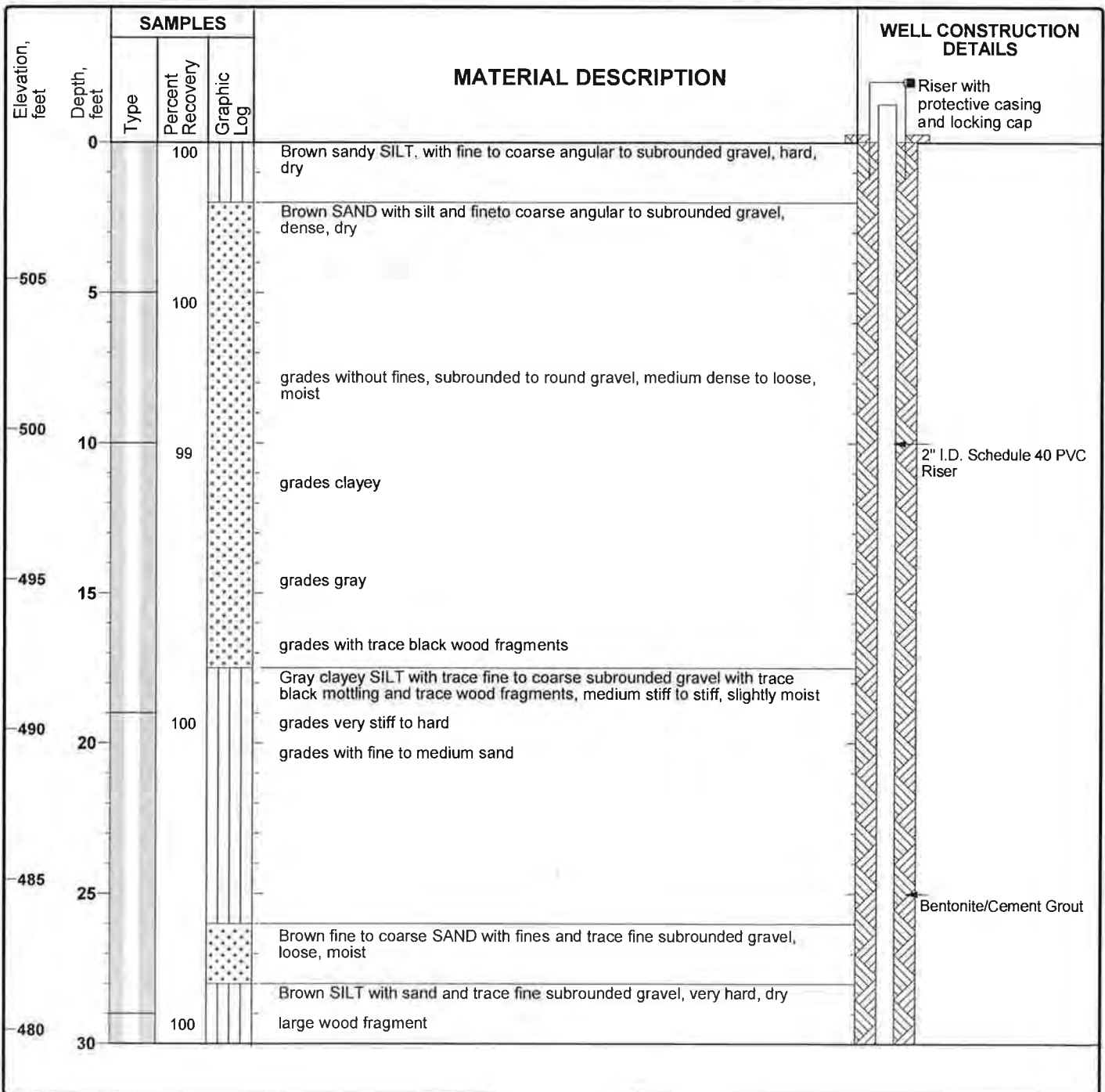

Project: Dynegy  
 Project Location: Zimmer Station  
 Project Number: 60442412

**Monitoring Well  
 MW-7A**  
 Sheet 2 of 2

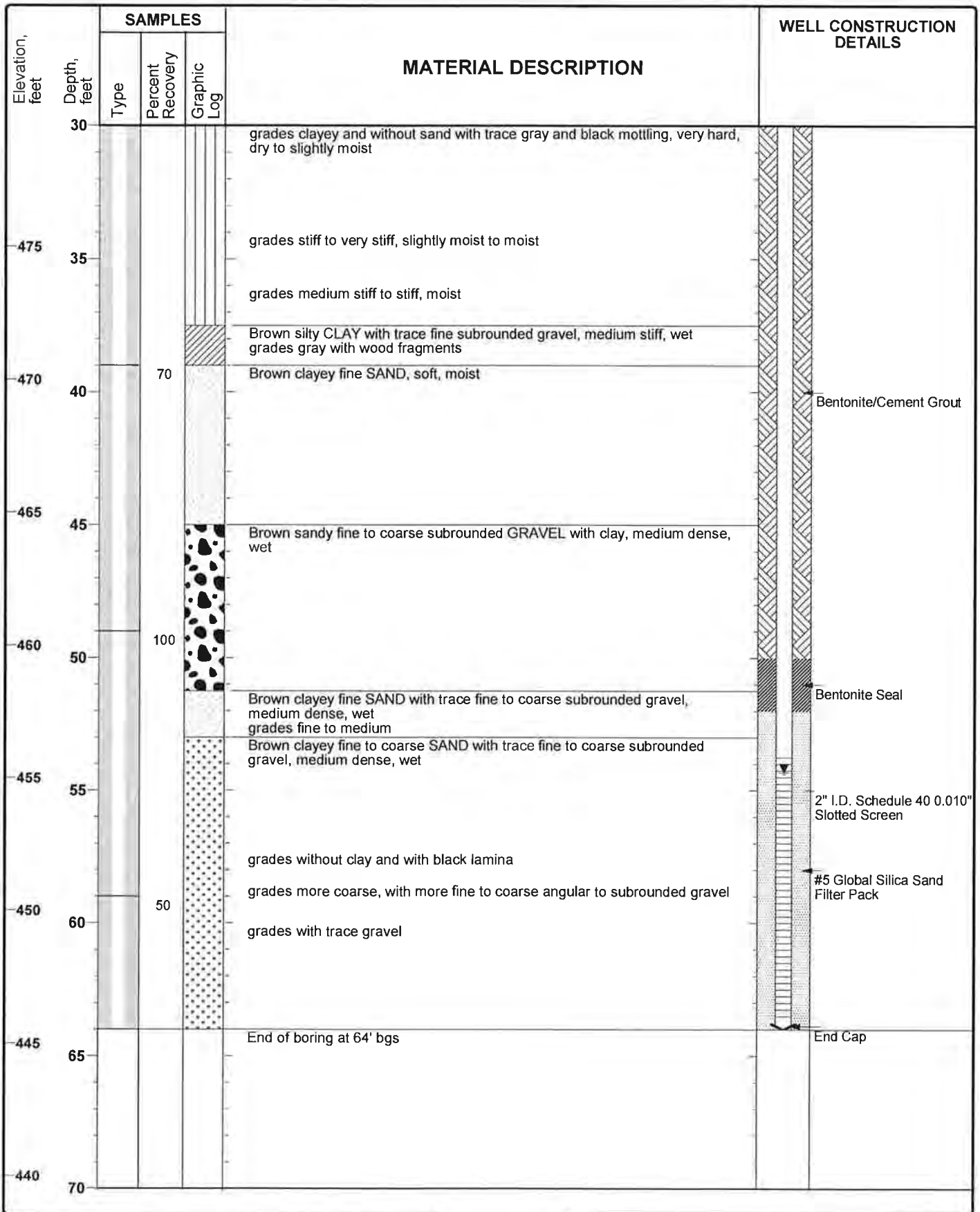



AMERICAN ELECTRIC POWER SERVICE CORPORATION  
AEP CIVIL ENGINEERING LABORATORY

JOB NO. \_\_\_\_\_  
COMPANY REP  
PROJECT Zimmerman Plant  
COORDINATES N-3270 E-130

LOG OF BORING

Renamed MW-8

BORING NO. 2124 DATE 4-20-89 SHEET 1 OF 5  
TYPE OF SAMPLES: SPT  3" TUBE \_\_\_\_\_ CORE \_\_\_\_\_  
CASING USED \_\_\_\_\_ SIZE \_\_\_\_\_ DRILLING MUD USED \_\_\_\_\_  
BORING BEGUN 4-20-89 BORING COMPLETED 4-25-89  
GROUND ELEVATION 54.1 REFERRED TO \_\_\_\_\_

LOCATION OF BORING: <u>Flood plain monitoring wells</u>	
WATER LEVEL	<u>28.5</u>
TIME	<u>10:00</u>
DATE	<u>4-20-89</u>

FIELD PARTY Houll - DART DATUM \_\_\_\_\_ RIG 75

SAMPLE NUMBER	SAMPLE DEPTH IN FEET		STANDARD PENETRATION RESISTANCE		TOTAL LENGTH RECOVERY	RQD %	DEPTH IN FEET	GRAPH LOG	USCS	SOIL / ROCK IDENTIFICATION	DRILLER'S NOTES
	FROM	TO	BLOW / 6"								
1	3.0	4.5	4	5	5	0				Limestone road base	
2	8.0	9.5	20	29	42	12"				Sand - Br - moist - QUARTZ STRONG REACTION TO HCL	SP
3	13.0	14.5	16	29	50	14"				Clayey sand Br - moist QUARTZ - TRACE OF GRANULE STRONG REACTION TO HCL	SC
4	18.0	19.5	17	29	45	16"				Sand - Br - moist - STRONG REACTION TO HCL - 90% FINE GRAIN - QUARTZ	SP
6" x 3.25 HSA HW CASING ADVANCER 4" NQ CORE ROCK							20				
NW CASING 3" SW CASING 6"											
RECORDER _____											

AMERICAN ELECTRIC POWER SERVICE CORPORATION  
AEP CIVIL ENGINEERING LABORATORY

LOG OF BORING

Renamed MW-8

JOB No. \_\_\_\_\_  
COMPANY \_\_\_\_\_  
PROJECT \_\_\_\_\_  
COORDINATES \_\_\_\_\_

BORING No. 2124 DATE \_\_\_\_\_ SHEET 2 OF 5  
TYPE OF SAMPLES: SPT \_\_\_\_\_ 3" TUBE \_\_\_\_\_ CORE \_\_\_\_\_  
CASING USED \_\_\_\_\_ SIZE \_\_\_\_\_ DRILLING MUD USED \_\_\_\_\_  
BORING BEGUN \_\_\_\_\_ BORING COMPLETED \_\_\_\_\_  
GROUND ELEVATION \_\_\_\_\_ REFERRED TO \_\_\_\_\_ DATUM \_\_\_\_\_  
FIELD PARTY \_\_\_\_\_ RIG \_\_\_\_\_

LOCATION OF BORING:	
WATER LEVEL	
TIME	
DATE	

SAMPLE NUMBER	SAMPLE DEPTH IN FEET		STANDARD PENETRATION RESISTANCE			TOTAL LENGTH RECOVERY	RQD %	DEPTH IN FEET	GRAPH LOG	U S C S	SOIL / ROCK IDENTIFICATION	DRILLER'S NOTES
	FROM	TO	BLDW / 6"									
								20				
5	23.0	24.5	12	19	35	15"					Sand - BR - moist. STRONG REACTION TO HCL - QUARTZ 80% FINE GRAIN	
6	28.0	29.5	SP			6"						
								30			Sand - BR - SATURATED - QUARTZ w/ BROKEN LIME STONE FRAG - STRONG REACTION TO HCL -	
7	33.0	34.5	18	15	21	14"						Clay - BR - moist - med to Low plasticity
8	38.0	39.5	7	9	12	16"						SAME AS - 7 TRACE OF V-FINE SAND
								40				
6" x 3.25 HSA HW CASING ADVANCER 4" NQ CORE ROCK												
NW CASING			3"									
SW CASING			6"									
RECORDER _____												

AMERICAN ELECTRIC POWER SERVICE CORPORATION  
AEP CIVIL ENGINEERING LABORATORY

LOG OF BORING

Renamed MW-8

JOB No. \_\_\_\_\_  
COMPANY \_\_\_\_\_  
PROJECT \_\_\_\_\_  
COORDINATES \_\_\_\_\_

BORING No. Z-124 DATE \_\_\_\_\_ SHEET 3 OF 5  
TYPE OF SAMPLES: SPT \_\_\_\_\_ 3" TUBE \_\_\_\_\_ CORE \_\_\_\_\_  
CASING USED \_\_\_\_\_ SIZE \_\_\_\_\_ DRILLING MUD USED \_\_\_\_\_  
BORING BEGUN \_\_\_\_\_ BORING COMPLETED \_\_\_\_\_  
GROUND ELEVATION \_\_\_\_\_ REFERRED TO \_\_\_\_\_ DATUM \_\_\_\_\_  
FIELD PARTY \_\_\_\_\_ RIG \_\_\_\_\_

LOCATION OF BORING:	
WATER LEVEL	
TIME	
DATE	

SAMPLE NUMBER	SAMPLE DEPTH IN FEET		STANDARD PENETRATION RESISTANCE BLOW / 6"			TOTAL LENGTH RECOVERY	RQD %	DEPTH IN FEET	GRAPH LOG	U S C S	SOIL / ROCK IDENTIFICATION	DRILLER'S NOTES
	FROM	TO	5	6	8							
								40				
9	43.0	44.5	5	6	8	16"					CL	TOP-6 CLAY - BR - WET - med to low plasticity
											SC	BOTTOM 10" CLAYEY SAND - BR - SATURATED 100% FINE GRAIN - QUARTZ
10	48.0	49.5	5	10	16	18"					SC	CLAYEY SAND - BR - SATURATED QUARTZ
								50				
11	53.0	54.5	12	15	15	16"					SP	SAND - BR - SATURATED QUARTZ - med to FINE GRAIN
12	58.0	59.5	12	15	23	15"					SW	SAND - BR - QUARTZ - SATURATED w/ TRACE OF PEG GRANULE
								60				
6" x 3.25 HSA HW CASING ADVANCER 4" NQ CORE ROCK												
NW CASING 3" SW CASING 6"												
										RECORDER		

AMERICAN ELECTRIC POWER SERVICE CORPORATION  
AEP CIVIL ENGINEERING LABORATORY

JOB NO. \_\_\_\_\_  
COMPANY \_\_\_\_\_  
PROJECT \_\_\_\_\_  
COORDINATES \_\_\_\_\_

LOG OF BORING

Renamed MW-8

BORING No. Z-124 DATE \_\_\_\_\_ SHEET 4 OF 5

TYPE OF SAMPLES: SPT \_\_\_\_\_ 3" TUBE \_\_\_\_\_ CORE \_\_\_\_\_

CASING USED \_\_\_\_\_ SIZE \_\_\_\_\_ DRILLING MUD USED \_\_\_\_\_

BORING BEGUN \_\_\_\_\_ BORING COMPLETED \_\_\_\_\_

GROUND ELEVATION \_\_\_\_\_ REFERRED TO \_\_\_\_\_

FIELD PARTY \_\_\_\_\_ DATUM \_\_\_\_\_  
Rig \_\_\_\_\_

LOCATION OF BORING:	
WATER LEVEL	
TIME	
DATE	

SAMPLE NUMBER	SAMPLE DEPTH IN FEET		STANDARD PENETRATION RESISTANCE BLOW / 6"				TOTAL LENGTH RECOVERY	RQD %	DEPTH IN FEET	GRAPH LOG	USCS	SOIL / ROCK IDENTIFICATION	DRILLER'S NOTES
	FROM	TO											
13	63.0	64.5	8	10	12	10"			60			Sand- BA- SATURATED med TO FINE GRAIN - QUARTZ	
14	68.0	69.5	8	10	15	14"							SAME AS 13 - STRONG REACTION TO HCL
15	73.0	74.5	6	10	16	12"			70				Sand- BA- QUARTZ - SATURATED 100% FINE GRAIN
16	78.0	79.5	6	16	24	15"							SAME AS 15
	6" x 3.25 HSA HW CASING ADVANCER 4" NQ CORE ROCK												
	NW CASING 3"		SW CASING 6"										
	RECORDER _____												

AMERICAN ELECTRIC POWER SERVICE CORPORATION  
AEP CIVIL ENGINEERING LABORATORY

LOG OF BORING

Renamed MW-8

JOB No. \_\_\_\_\_  
COMPANY \_\_\_\_\_  
PROJECT \_\_\_\_\_  
COORDINATES \_\_\_\_\_

BORING No. 2124 DATE \_\_\_\_\_ SHEET 5 OF 5  
TYPE OF SAMPLES: SPT \_\_\_\_\_ 3" TUBE \_\_\_\_\_ CORE \_\_\_\_\_  
CASING USED \_\_\_\_\_ SIZE \_\_\_\_\_ DRILLING MUD USED \_\_\_\_\_  
BORING BEGUN \_\_\_\_\_ BORING COMPLETED \_\_\_\_\_  
GROUND ELEVATION \_\_\_\_\_ REFERRED TO \_\_\_\_\_ DATUM \_\_\_\_\_  
FIELD PARTY \_\_\_\_\_ RIG \_\_\_\_\_

LOCATION OF BORING:	
WATER LEVEL	
TIME	
DATE	

SAMPLE NUMBER	SAMPLE DEPTH IN FEET		STANDARD PENETRATION RESISTANCE			TOTAL LENGTH RECOVERY	RQD %	DEPTH IN FEET	GRAPH LOG	USCS	SOIL / ROCK IDENTIFICATION	DRILLER'S NOTES
	FROM	TO	BLOW / 6"									
17	83.0	84.5	16	27	43	13"		80		GM	SILT / SAND + GRAVEL - BR SATURATED - QUARTZ - 1" MAX SIZE - ANGLULAR -	
18	88.0	89.5	11	14	15	12"		90		SW	SAND - BR - SATURATED - TRACE OF FINE S - STRAWS REACTION TO HCL - TRACE OF FINE S	
19	93.0	94.5	10	14	16	14"					SAME AS 18"	
6" x 3.25 HSA HW CASING ADVANCER 4" NQ CORE ROCK												
NW CASING 3" SW CASING 6"												
											Stopped Hole 96.1 INSTALLED WELL	
											RECORDED	



**Project: Dynegy**  
**Project Location: Zimmer Station**  
**Project Number: 60442412**

**Monitoring Well**  
**MW-10**  
 Sheet 1 of 2

Date(s) Drilled	12/10/15	Logged By	Becky Smolenski	Checked By	Mike Wagner
Drilling Method	Rotosonic	Drilling Contractor	Frontz Drilling	Total Depth of Borehole	65.0 feet
Date of Groundwater Measurement	12/21/15	Sampler Type	Sonic Sleeve	Surface Elevation	509.36 feet, msl
Depth to Groundwater	52.5 ft bgs	Seal Material	Hydrated 3/8-inch Bentonite Chips	Top of PVC Elevation	512.18 feet, msl
Diameter of Hole (inches)	6.0	Diameter of Well (inches)	2	Type of Well Casing	Schedule 40 PVC
Type of Sand Pack	#5 Silica Sand	Well Completion at Ground Surface	Riser, With locking cap and protective casing.		
Comments					

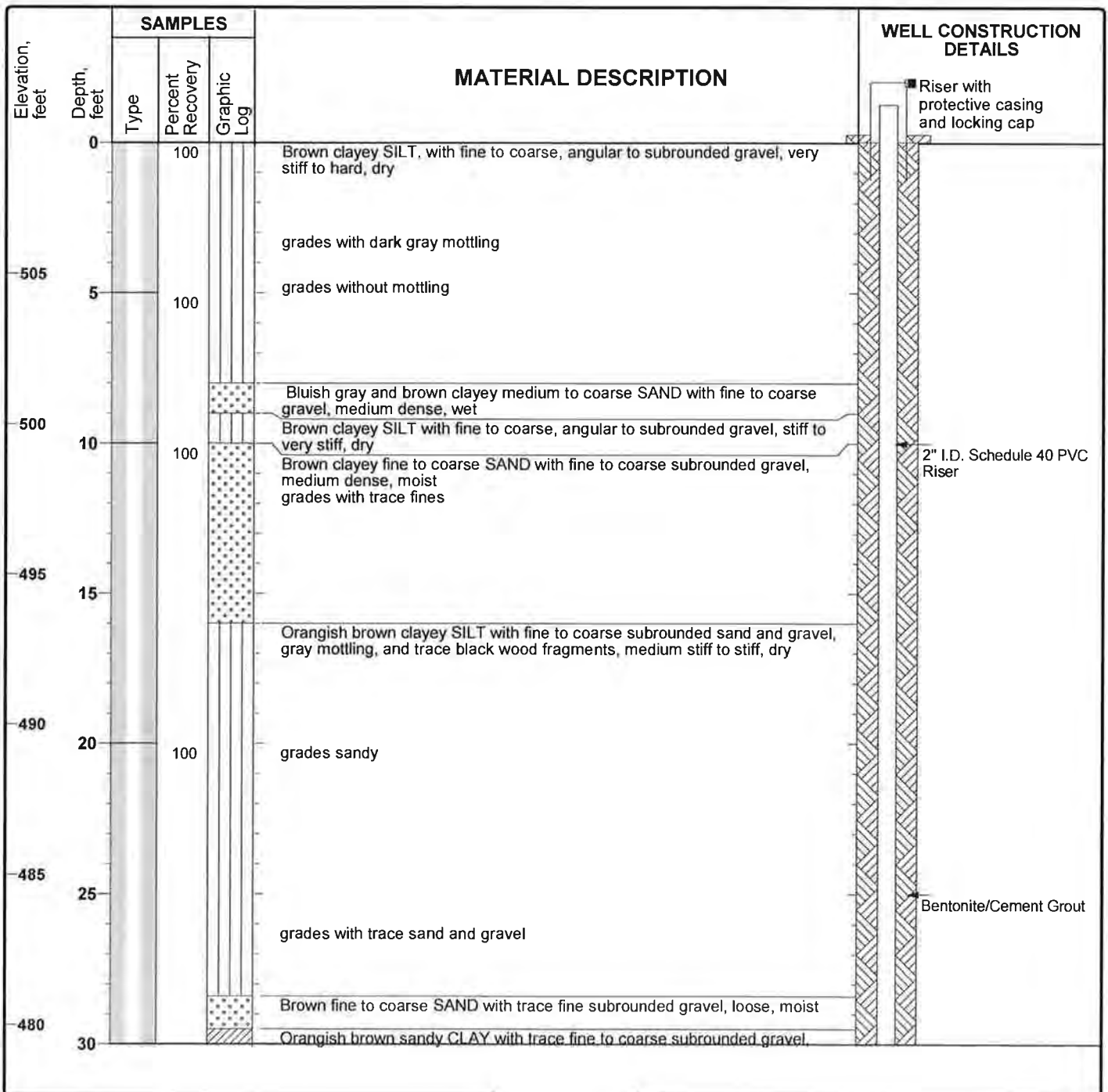

Project: Dynegy  
 Project Location: Zimmer Station  
 Project Number: 60442412

**Monitoring Well  
 MW-10**  
 Sheet 2 of 2

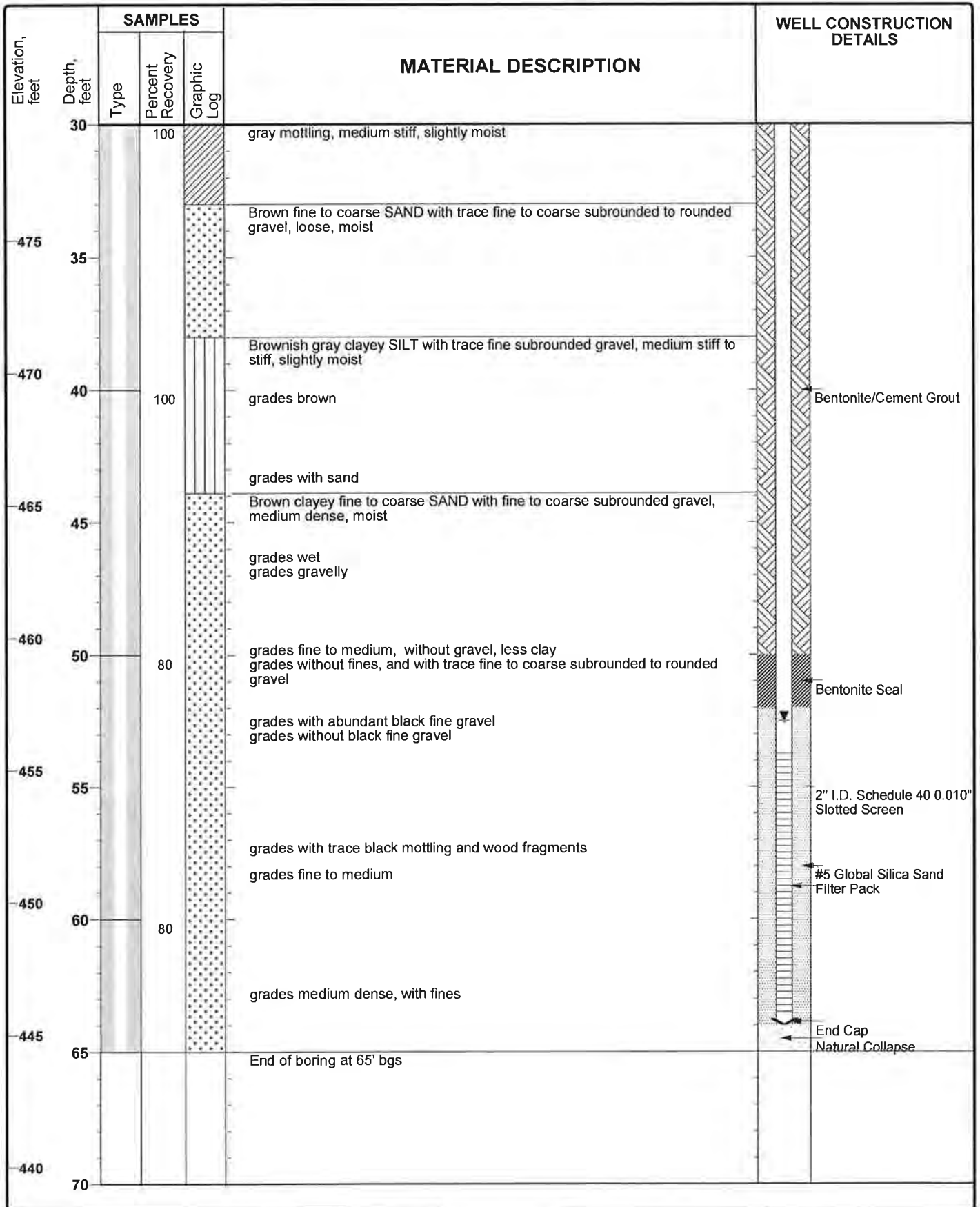

**Project: Dynegy**  
**Project Location: Zimmer Station**  
**Project Number: 60442412**

**Monitoring Well**  
**MW-11**  
 Sheet 1 of 2

Date(s) Drilled	12/2/15	Logged By	Becky Smolenski	Checked By	Mike Wagner
Drilling Method	Rotosonic	Drilling Contractor	Frontz Drilling	Total Depth of Borehole	64.0 feet
Date of Groundwater Measurement	12/21/15	Sampler Type	Sonic Sleeve	Surface Elevation	509.18 feet, msl
Depth to Groundwater	51.5 ft bgs	Seal Material	Hydrated 3/8-inch Bentonite Chips	Top of PVC Elevation	508.87 feet, msl
Diameter of Hole (inches)	6.0	Diameter of Well (inches)	2	Type of Well Casing	Schedule 40 PVC
Type of Sand Pack	#5 Silica Sand	Well Completion at Ground Surface	Riser, With locking cap and protective casing.		
Comments					

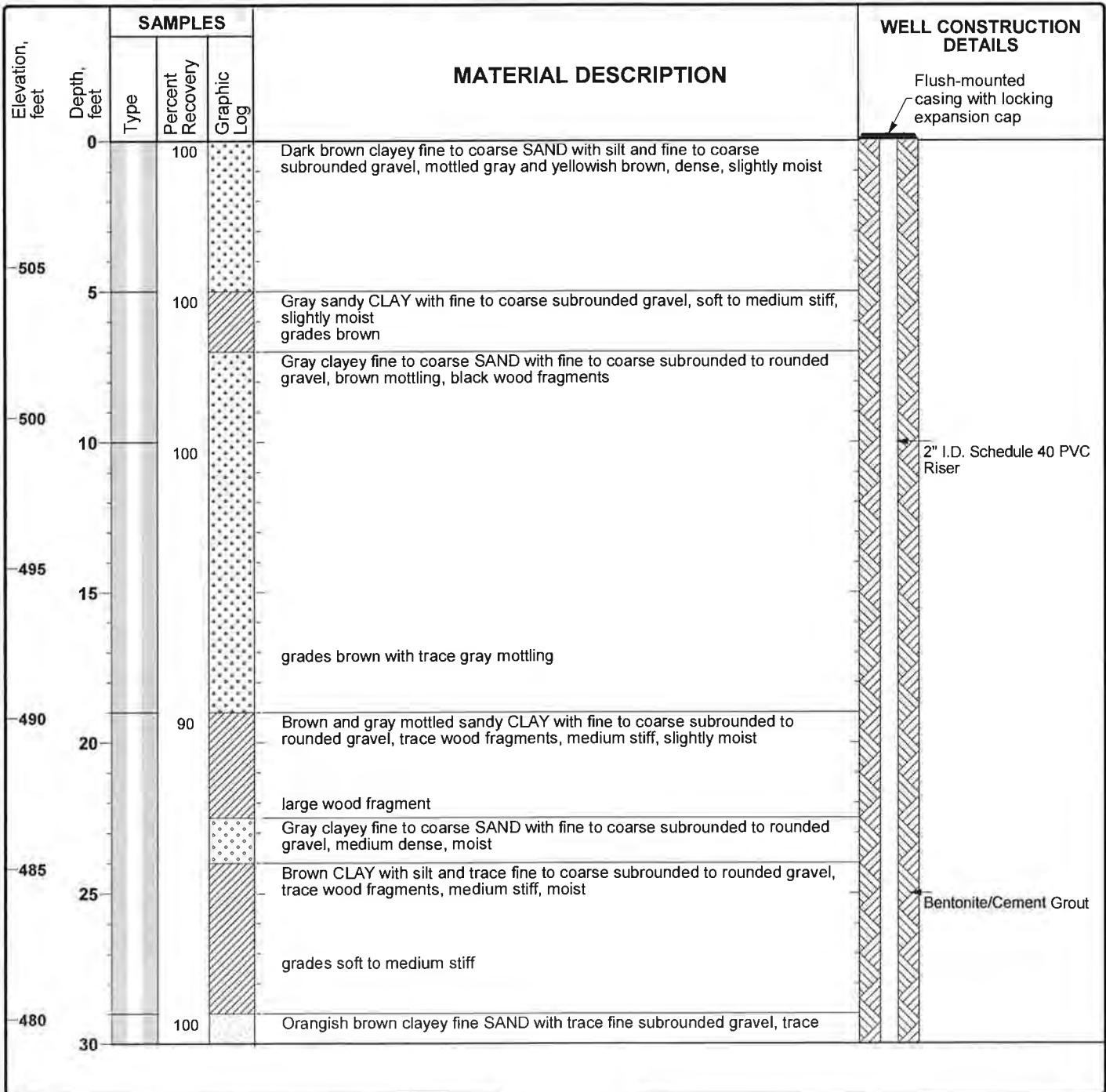



Project: Dynegy  
 Project Location: Zimmer Station  
 Project Number: 60442412

Monitoring Well  
 MW-11  
 Sheet 2 of 2

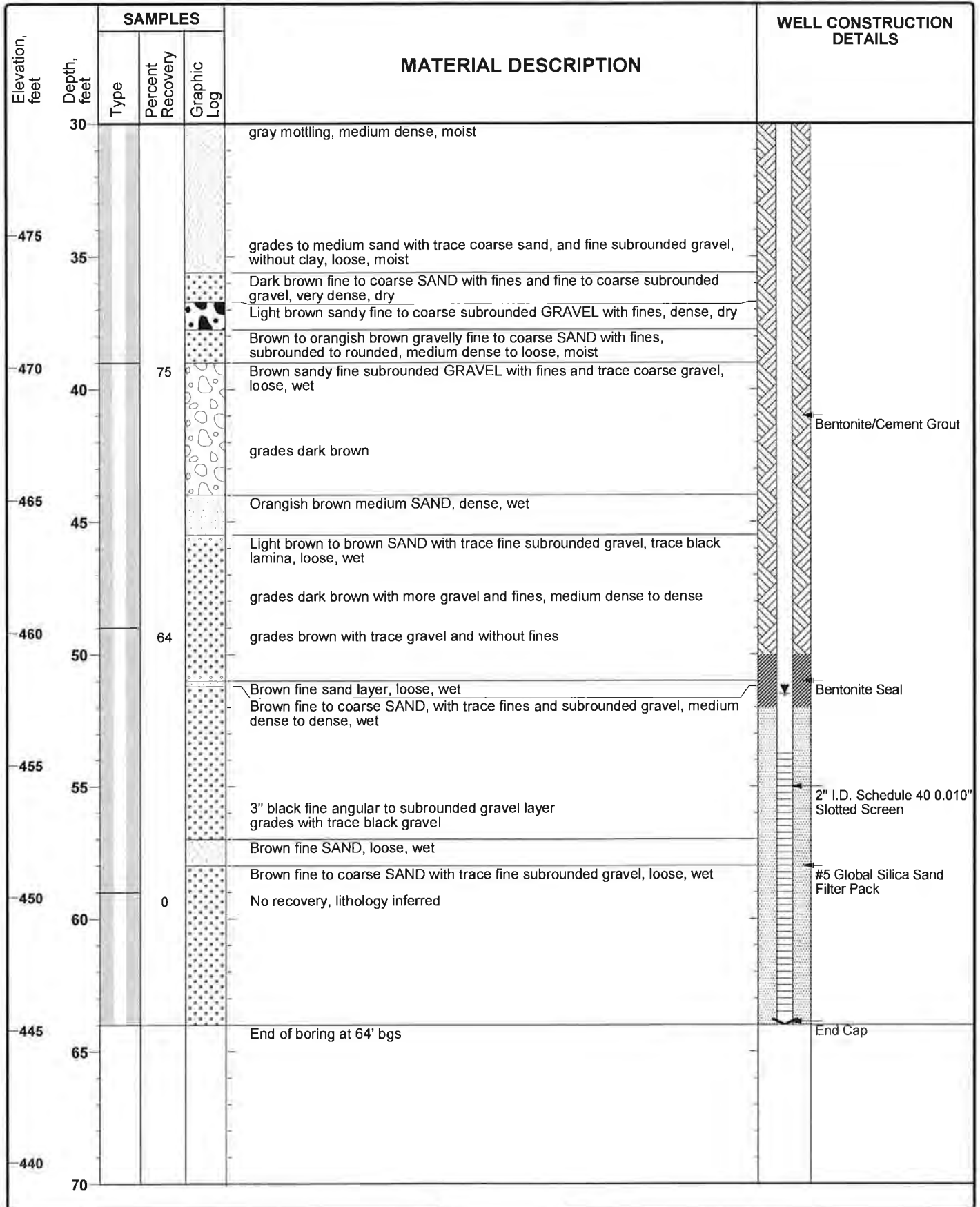

Job No. \_\_\_\_\_  
 COMPANY Zimmer Plant  
 PROJECT Flood plain monitoring well  
 COORDINATES N-3270 E-130  
 DATE 4/26/89 TIME \_\_\_\_\_

**WELL CONSTRUCTION  
 SUMMARY ELEVATIONS  
 (ft. NGVD)**

WELL No. 8  
 REF. DATUM PT. 513.1  
 Renamed MW-8  
 GRADE 511.1

1. GROUT SEAL Volclay Grout  
511.1 to 441.0
2. BENTONITE SEAL
3. SCREEN 20' x 2" x .02 PVC
4. GRAVEL PACK natural sand
5. N. A.
6. RISER PIPE 2" PVC

Water level 4/27/89, 18 hrs.  
 Elevation 464.4

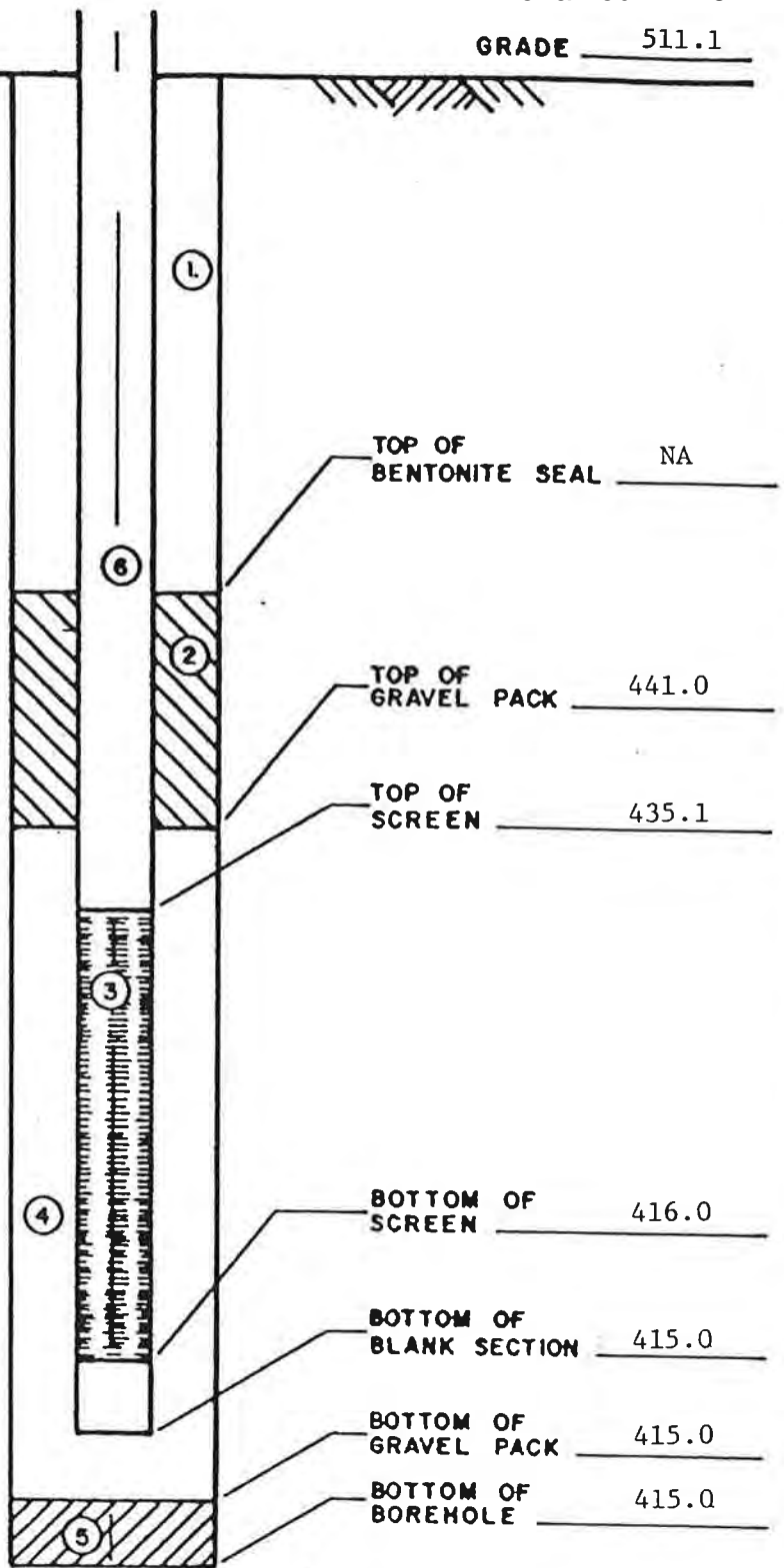

GEOTECHNICAL ENGINEERING SECTION CIVIL DESIGN STANDARD		REVISION		OBSERVATION WELL	
APPROVED	DR.	CH.	_____	CDS-04	SH.
AMERICAN ELECTRIC POWER SVC. CORP.				CDS-04	SH.



AMERICAN ELECTRIC POWER SERVICE CORPORATION  
AEP CIVIL ENGINEERING LABORATORY

Job No. \_\_\_\_\_  
 COMPANY \_\_\_\_\_  
 PROJECT \_\_\_\_\_  
 COORDINATES \_\_\_\_\_

LOG OF BORING

Renamed MW-1

BORING No. 2117 DATE \_\_\_\_\_ SHEET 2 OF \_\_\_\_\_  
 TYPE OF SAMPLES: SPT \_\_\_\_\_ 3" TUBE \_\_\_\_\_ CORE \_\_\_\_\_  
 CASING USED \_\_\_\_\_ SIZE \_\_\_\_\_ DRILLING MUD USED \_\_\_\_\_  
 BORING BEGUN \_\_\_\_\_ BORING COMPLETED \_\_\_\_\_  
 GROUND ELEVATION \_\_\_\_\_ REFERRED TO \_\_\_\_\_ DATUM \_\_\_\_\_  
 FIELD PARTY \_\_\_\_\_ RIG \_\_\_\_\_

LOCATION OF BORING:	
WATER LEVEL	
TIME	
DATE	

SAMPLE NUMBER	SAMPLE DEPTH IN FEET		STANDARD PENETRATION RESISTANCE BLOW / 6"			TOTAL LENGTH RECOVERY	RQD %	DEPTH IN FEET	GRAPH LOG	USCS	SOIL / ROCK IDENTIFICATION	DRILLER'S NOTES
	FROM	TO										
								20				
5	22.5	24.0	2	3	4	18"					top 9" Clay - yellowish Br - moist to wet - med to low plasticity	
											CL	
											bottom 9" Clay - Gray - wet - med to low plasticity	
											CL	
6	27.5	29.0	2	3	3	18"					Clay - Gray - wet - med to low plasticity	
											CL	
								30				
7	32.5	34.0	1	2	3	18"					Same as 6	
8	37.5	39.0	20	26	12	16"					Sand + Gravel - Gray - Br - saturated - Quartz - Rounded 1/2" max size w/ fines	
											GM	
								40				
6" x 3.25 HSA HW CASING ADVANCER 4" NQ CORE ROCK												
NW CASING 3"			SW CASING 6"									
RECORDER _____												





AMERICAN ELECTRIC POWER SERVICE CORPORATION  
AEP CIVIL ENGINEERING LABORATORY

JOB NO. \_\_\_\_\_  
COMPANY \_\_\_\_\_  
PROJECT \_\_\_\_\_  
COORDINATES \_\_\_\_\_

LOG OF BORING

Renamed MW-1

BORING NO. 2117 DATE \_\_\_\_\_ SHEET 4 OF \_\_\_\_\_  
TYPE OF SAMPLES: SPT \_\_\_\_\_ 3" TUBE \_\_\_\_\_ CORE \_\_\_\_\_  
CASING USED \_\_\_\_\_ SIZE \_\_\_\_\_ DRILLING MUD USED \_\_\_\_\_  
BORING BEGUN \_\_\_\_\_ BORING COMPLETED \_\_\_\_\_  
GROUND ELEVATION \_\_\_\_\_ REFERRED TO \_\_\_\_\_ DATUM \_\_\_\_\_  
FIELD PARTY \_\_\_\_\_ RIG \_\_\_\_\_

LOCATION OF BORING:	
WATER LEVEL	
TIME	
DATE	

SAMPLE NUMBER	SAMPLE DEPTH IN FEET		STANDARD PENETRATION RESISTANCE			TOTAL LENGTH RECOVERY	RQO %	DEPTH IN FEET	GRAPH LOG	USCS	SOIL / ROCK IDENTIFICATION	DRILLER'S NOTES
	FROM	TO	BLOW / 6"									
								60				
13	62.5	64.0	16	17	11	13"					GRAVELLY SILTY SAND - BR. SATURATED - QUARTZ - 3/4" MAX SIZE - STRONG REACTION TO HCL	
14	67.5	69.0	29	39	31	16"					SAND + GRAVEL - BR. SATURATED QUARTZ - 1" MAX SIZE - 4/5 FINES - STRONG REACTION TO HCL	
								70				
15	72.5	74.0	12	28	40	8"					CLAYEY SAND + GRAVEL BR. SATURATED - 1" MAX SIZE ROUNDED - QUARTZ - STRONG REACTION TO HCL	
16	77.5	79.0	14	30	38	9"					Same as 15	
								80				
6" x 3.25 HSA HW CASING ADVANCER 4" NQ CORE ROCK												
NW CASING			3"									
SW CASING			6"									
											RECORDER _____	



AMERICAN ELECTRIC POWER SERVICE CORPORATION  
AEP CIVIL ENGINEERING LABORATORY

JOB NO. \_\_\_\_\_  
COMPANY REP  
PROJECT Zimmerman Plant  
COORDINATES N-3270 E-130

LOG OF BORING

Renamed MW-8

BORING NO. 2124 DATE 4-20-89 SHEET 1 OF 5  
TYPE OF SAMPLES: SPT  3" TUBE \_\_\_\_\_ CORE \_\_\_\_\_  
CASING USED \_\_\_\_\_ SIZE \_\_\_\_\_ DRILLING MUD USED \_\_\_\_\_  
BORING BEGUN 4-20-89 BORING COMPLETED 4-25-89  
GROUND ELEVATION 54.1 REFERRED TO \_\_\_\_\_

LOCATION OF BORING: <u>Flood plain monitoring wells</u>	
WATER LEVEL	<u>28.5</u>
TIME	<u>10:00</u>
DATE	<u>4-20-89</u>

FIELD PARTY Houll - DART DATUM \_\_\_\_\_ RIG 75

SAMPLE NUMBER	SAMPLE DEPTH IN FEET		STANDARD PENETRATION RESISTANCE		TOTAL LENGTH RECOVERY	RQD %	DEPTH IN FEET	GRAPH LOG	USCS	SOIL / ROCK IDENTIFICATION	DRILLER'S NOTES
	FROM	TO	BLOW / 6"								
1	3.0	4.5	4	5	5	0				Limestone road base	
2	8.0	9.5	20	29	42	12"				Sand - Br - moist - QUARTZ STRONG REACTION TO HCL	SP
3	13.0	14.5	16	29	50	14"				Clayey sand Br - moist QUARTZ - TRACE OF GRANULE STRONG REACTION TO HCL	SC
4	18.0	19.5	17	29	45	16"				Sand - Br - moist - STRONG REACTION TO HCL - 90% FINE GRAIN - QUARTZ	SP
6" x 3.25 HSA HW CASING ADVANCER 4" NQ CORE ROCK							20				
NW CASING 3" SW CASING 6"											
RECORDER _____											



AMERICAN ELECTRIC POWER SERVICE CORPORATION  
AEP CIVIL ENGINEERING LABORATORY

LOG OF BORING

Renamed MW-8

JOB NO. \_\_\_\_\_  
COMPANY \_\_\_\_\_  
PROJECT \_\_\_\_\_  
COORDINATES \_\_\_\_\_

BORING No. 2124 DATE \_\_\_\_\_ SHEET 2 OF 5  
TYPE OF SAMPLES: SPT \_\_\_\_\_ 3" TUBE \_\_\_\_\_ CORE \_\_\_\_\_  
CASING USED \_\_\_\_\_ SIZE \_\_\_\_\_ DRILLING MUD USED \_\_\_\_\_  
BORING BEGUN \_\_\_\_\_ BORING COMPLETED \_\_\_\_\_  
GROUND ELEVATION \_\_\_\_\_ REFERRED TO \_\_\_\_\_ DATUM \_\_\_\_\_  
FIELD PARTY \_\_\_\_\_ RIG \_\_\_\_\_

LOCATION OF BORING:	
WATER LEVEL	
TIME	
DATE	

SAMPLE NUMBER	SAMPLE DEPTH IN FEET		STANDARD PENETRATION RESISTANCE			TOTAL LENGTH RECOVERY	RQD %	DEPTH IN FEET	GRAPH LOG	U S C S	SOIL / ROCK IDENTIFICATION	DRILLER'S NOTES
	FROM	TO	BLDW / 6"									
								20				
5	23.0	24.5	12	19	35	15"					Sand - BR - moist - strong reaction to HCL - QUARTZ 80% FINE GRAIN	
6	28.0	29.5	SP			6"					Sand - BR - SATURATED - QUARTZ w/3 Broken Lime Stone FRAG - STRONG REACTION TO HCL -	
								30				
7	33.0	34.5	18	15	21	14"					Clay - BR - moist - med to Low plasticity	
8	38.0	39.5	7	9	12	16"					SAME AS - 7 TRACE OF V-FINE SAND	
								40				
6" x 3.25 HSA HW CASING ADVANCER 4" NQ CORE ROCK												
NW CASING			3"									
SW CASING			6"									
RECORDER _____												

AMERICAN ELECTRIC POWER SERVICE CORPORATION  
AEP CIVIL ENGINEERING LABORATORY

LOG OF BORING

Renamed MW-8

JOB No. \_\_\_\_\_  
COMPANY \_\_\_\_\_  
PROJECT \_\_\_\_\_  
COORDINATES \_\_\_\_\_

BORING No. Z-124 DATE \_\_\_\_\_ SHEET 3 OF 5  
TYPE OF SAMPLES: SPT \_\_\_\_\_ 3" TUBE \_\_\_\_\_ CORE \_\_\_\_\_  
CASING USED \_\_\_\_\_ SIZE \_\_\_\_\_ DRILLING MUD USED \_\_\_\_\_  
BORING BEGUN \_\_\_\_\_ BORING COMPLETED \_\_\_\_\_  
GROUND ELEVATION \_\_\_\_\_ REFERRED TO \_\_\_\_\_ DATUM \_\_\_\_\_  
FIELD PARTY \_\_\_\_\_ RIG \_\_\_\_\_

LOCATION OF BORING:	
WATER LEVEL	
TIME	
DATE	

SAMPLE NUMBER	SAMPLE DEPTH IN FEET		STANDARD PENETRATION RESISTANCE BLOW / 6"				TOTAL LENGTH RECOVERY	RQD %	DEPTH IN FEET	GRAPH LOG	U S C S	SOIL / ROCK IDENTIFICATION	DRILLER'S NOTES	
	FROM	TO	5	6	8	16"								
									40					
9	43.0	44.5	5	6	8	16"						TOP-6 CLAY - BR - WET - med to low plasticity		
												CL Bottom 10" CLAYEY SAND - BR - SATURATED 100% FINE GRAIN - QUARTZ		
												SC		
10	48.0	49.5	5	10	16	18"						CLAYEY SAND - BR - SATURATED QUARTZ		
									50			SC		
11	53.0	54.5	12	15	15	16"						SAND - BR - SATURATED QUARTZ - med to FINE GRAIN		
												SP		
12	58.0	59.5	12	15	23	15"						SAND - BR - QUARTZ - SATURATED w/ TRACE OF PEAGRAIN		
									60			SW		
	6" x 3.25 HSA HW CASING ADVANCER 4" NQ CORE ROCK													
	NW CASING 3"													
	SW CASING 6"													
	RECORDER _____													

AMERICAN ELECTRIC POWER SERVICE CORPORATION  
AEP CIVIL ENGINEERING LABORATORY

LOG OF BORING

Renamed MW-8

Job No. \_\_\_\_\_  
Company \_\_\_\_\_  
Project \_\_\_\_\_  
Coordinates \_\_\_\_\_

BORING No. Z-124 DATE \_\_\_\_\_ SHEET 4 OF 5

TYPE OF SAMPLES: SPT \_\_\_\_\_ 3" TUBE \_\_\_\_\_ CORE \_\_\_\_\_

CASING USED \_\_\_\_\_ SIZE \_\_\_\_\_ DRILLING MUD USED \_\_\_\_\_

BORING BEGUN \_\_\_\_\_ BORING COMPLETED \_\_\_\_\_

GROUND ELEVATION \_\_\_\_\_ REFERRED TO \_\_\_\_\_

FIELD PARTY \_\_\_\_\_ DATUM \_\_\_\_\_  
Rig \_\_\_\_\_

LOCATION OF BORING:	
WATER LEVEL	
TIME	
DATE	

SAMPLE NUMBER	SAMPLE DEPTH IN FEET		STANDARD PENETRATION RESISTANCE				TOTAL LENGTH RECOVERY	RQD %	DEPTH IN FEET	GRAPH LOG	USCS	SOIL / ROCK IDENTIFICATION	DRILLER'S NOTES
	FROM	TO	BLOW / 6"										
									60				
13	63.0	64.5	8	10	12	10"						Sand- BA- SATURATED med TO FINE GRAIN - QUARTZ	
												SP	
14	68.0	69.5	8	10	15	14"						SAME AS 13 - STRONG REACTION TO HCL	
									70				
15	73.0	74.5	6	10	16	12"						Sand- BA- QUARTZ - SATURATED 100% FINE GRAIN	
16	78.0	79.5	6	16	24	15"						SAME AS 15	
	6" x 3.25 HSA HW CASING ADVANCER 4" NQ CORE ROCK												
	NW CASING 3"		SW CASING 6"										
	RECORDER _____												



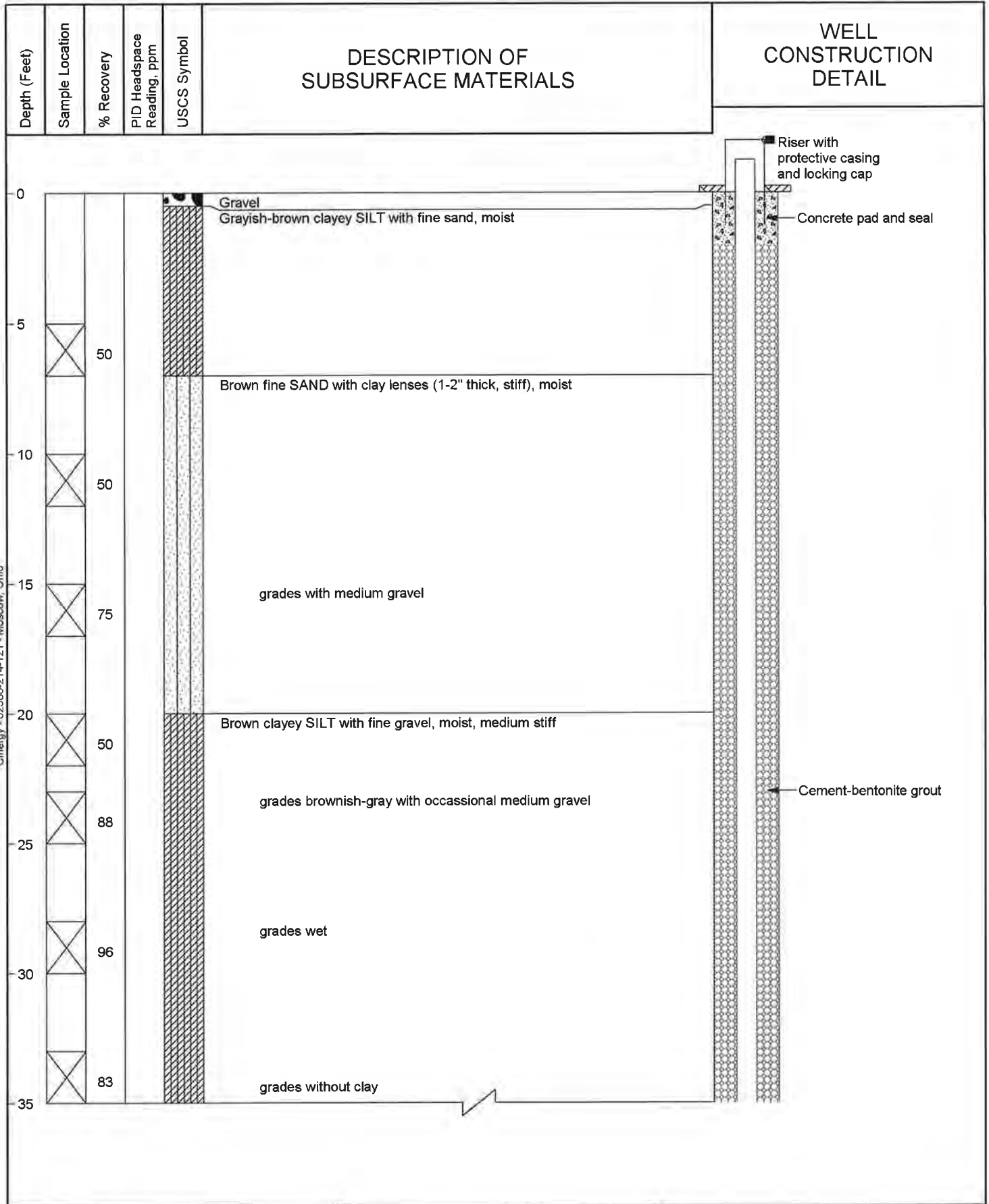

Cinergy - 02580-214-121 - Moscow, Ohio



JOB NO. 02580-214-121

**Cinergy**  
Zimmer Generating Station

Moscow, Ohio

**SOIL BORING**  
MW-9



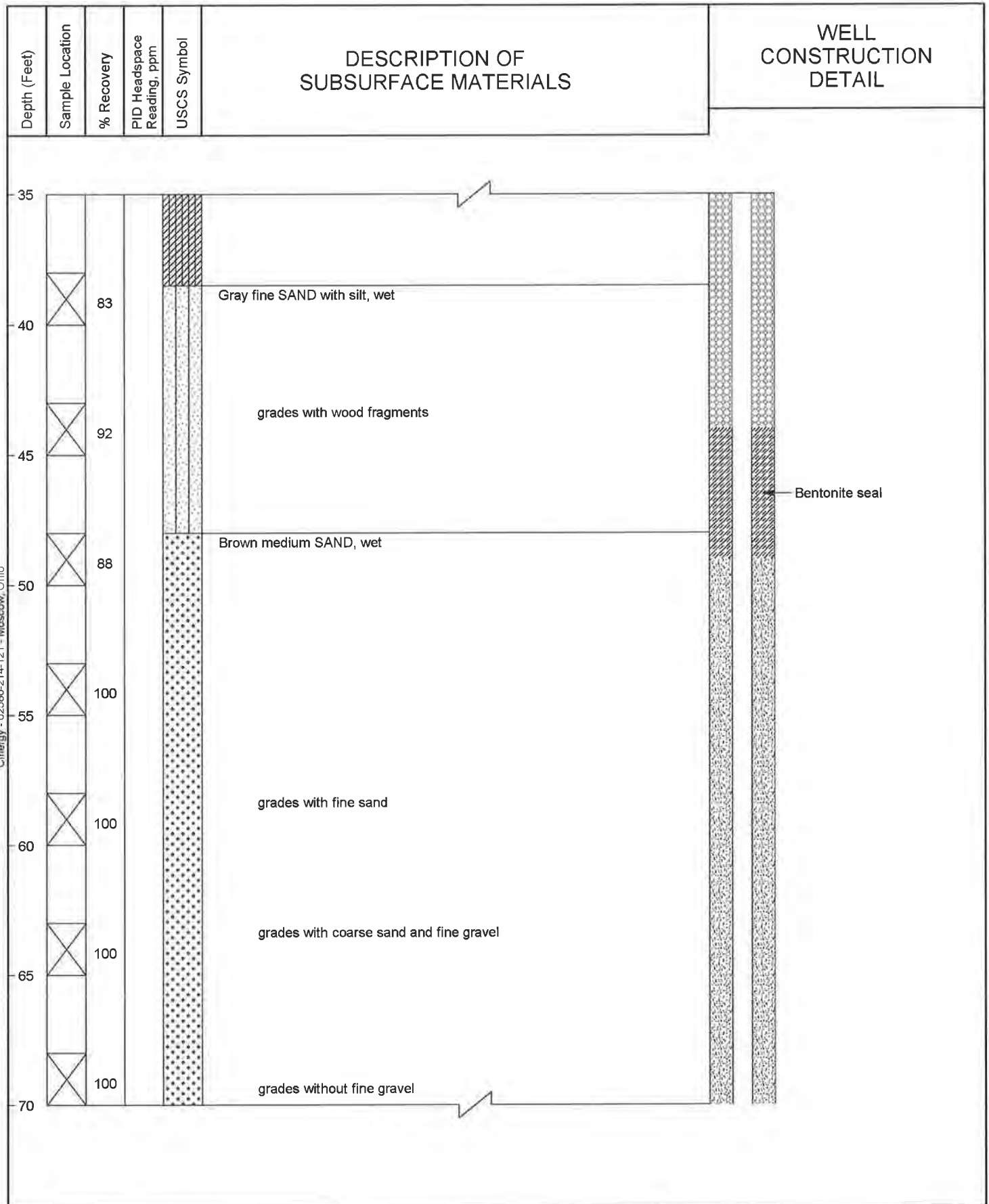

Cinergy - 02580-214-121 - Moscow, Ohio



JOB NO. 02580-214-121

**Cinergy**  
Zimmer Generating Station



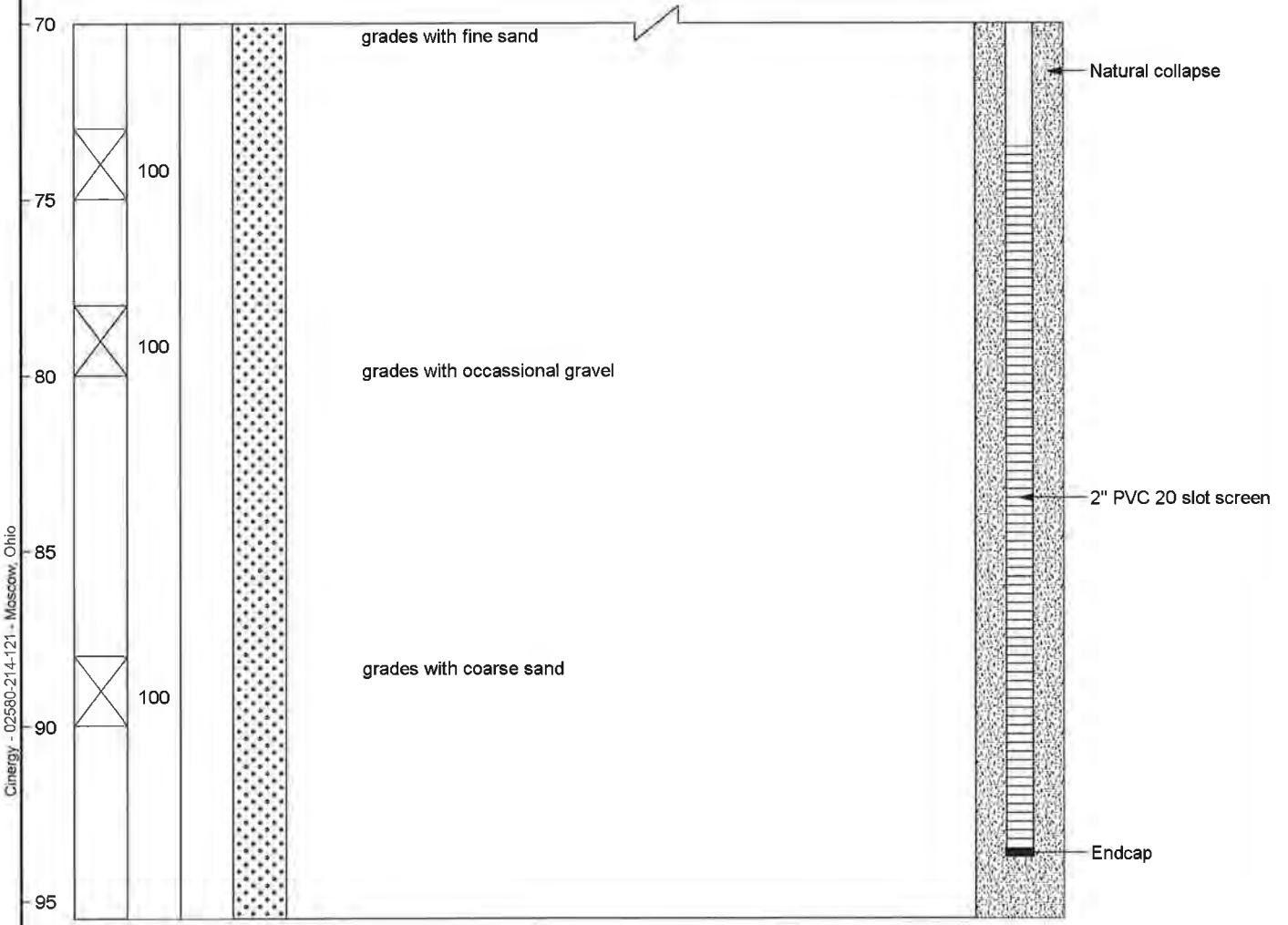

Moscow, Ohio

**SOIL BORING**  
MW-9

Depth (Feet)	Sample Location	% Recovery	PID Headspace Reading, ppm	USCS Symbol	DESCRIPTION OF SUBSURFACE MATERIALS	WELL CONSTRUCTION DETAIL
--------------	-----------------	------------	----------------------------	-------------	-------------------------------------	--------------------------



End of boring at 95.2 ft. bgs.  
Monitoring well installed to 93.5 ft. bgs. on 10/15/2003.

- LEGEND:**
-  Auger Cuttings
  -  Split Spoon
  -  PID Photoionization Detector
  -  bgs Below ground surface

Geff ZIMMER GPJ 11/11/05

**Project: Dynegy**  
**Project Location: Zimmer Station**  
**Project Number: 60442412**

**Monitoring Well**  
**MW-12**  
 Sheet 1 of 2

Date(s) Drilled	11/20/15	Logged By	Becky Smolenski	Checked By	Mike Wagner
Drilling Method	Rotosonic	Drilling Contractor	Frontz Drilling	Total Depth of Borehole	64.0 feet
Date of Groundwater Measurement	12/08/15	Sampler Type	Sonic Sleeve	Surface Elevation	509.34 feet, msl
Depth to Groundwater	53.19 ft bgs	Seal Material	Hydrated 3/8-inch Bentonite Chips	Top of PVC Elevation	511.92 feet, msl
Diameter of Hole (inches)	6.0	Diameter of Well (inches)	2	Type of Well Casing	Schedule 40 PVC
Type of Sand Pack	#5 Silica Sand	Well Completion at Ground Surface	Riser, With locking cap and protective casing.		
Comments					

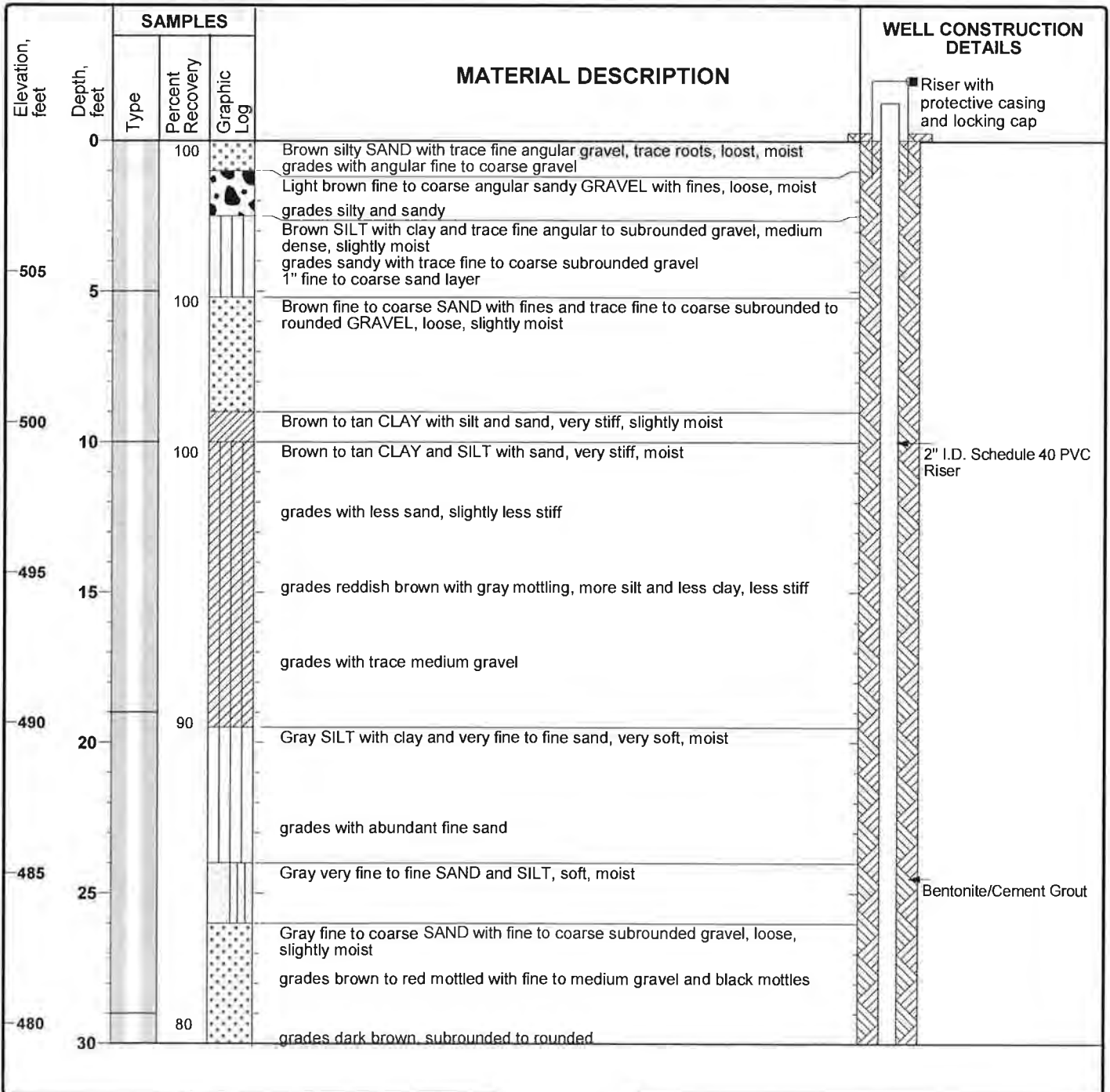



**Project: Dynegy**  
**Project Location: Zimmer Station**  
**Project Number: 60442412**

**Monitoring Well**  
**MW-12**  
 Sheet 2 of 2

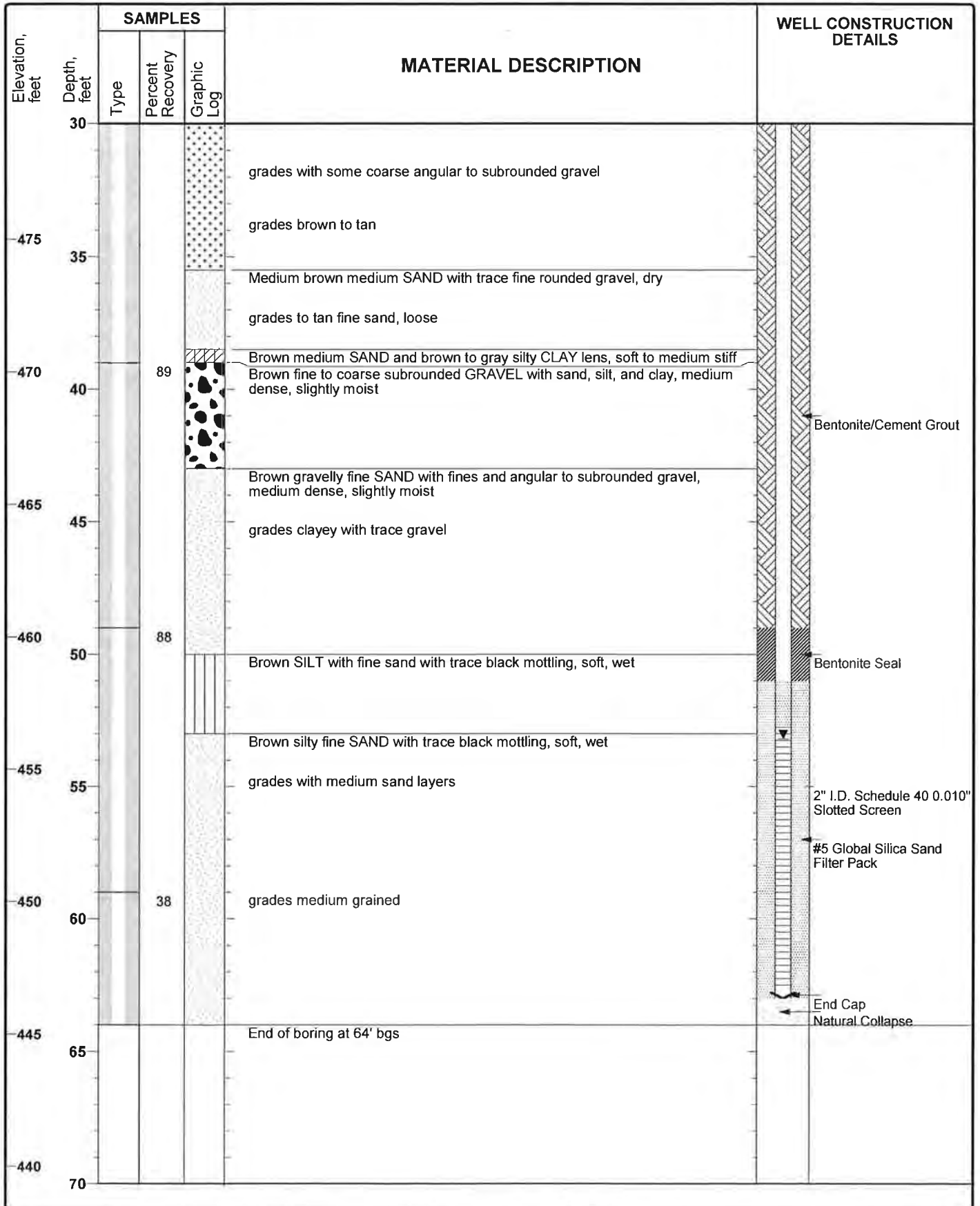

**Project: Dynegy**  
**Project Location: Zimmer Station**  
**Project Number: 60442412**

**Monitoring Well**  
**MW-13**  
 Sheet 1 of 2

Date(s) Drilled	11/24/15	Logged By	Becky Smolenski	Checked By	Mike Wagner
Drilling Method	Rotosonic	Drilling Contractor	Frontz Drilling	Total Depth of Borehole	54.0 feet
Date of Groundwater Measurement	12/08/15	Sampler Type	Sonic Sleeve	Surface Elevation	497.21 feet, msl
Depth to Groundwater	39.51 ft bgs	Seal Material	Hydrated 3/8-inch Bentonite Chips	Top of PVC Elevation	499.4 feet, msl
Diameter of Hole (inches)	6.0	Diameter of Well (inches)	2	Type of Well Casing	Schedule 40 PVC
Type of Sand Pack	#5 Silica Sand	Well Completion at Ground Surface	Riser, With locking cap and protective casing.		
Comments					

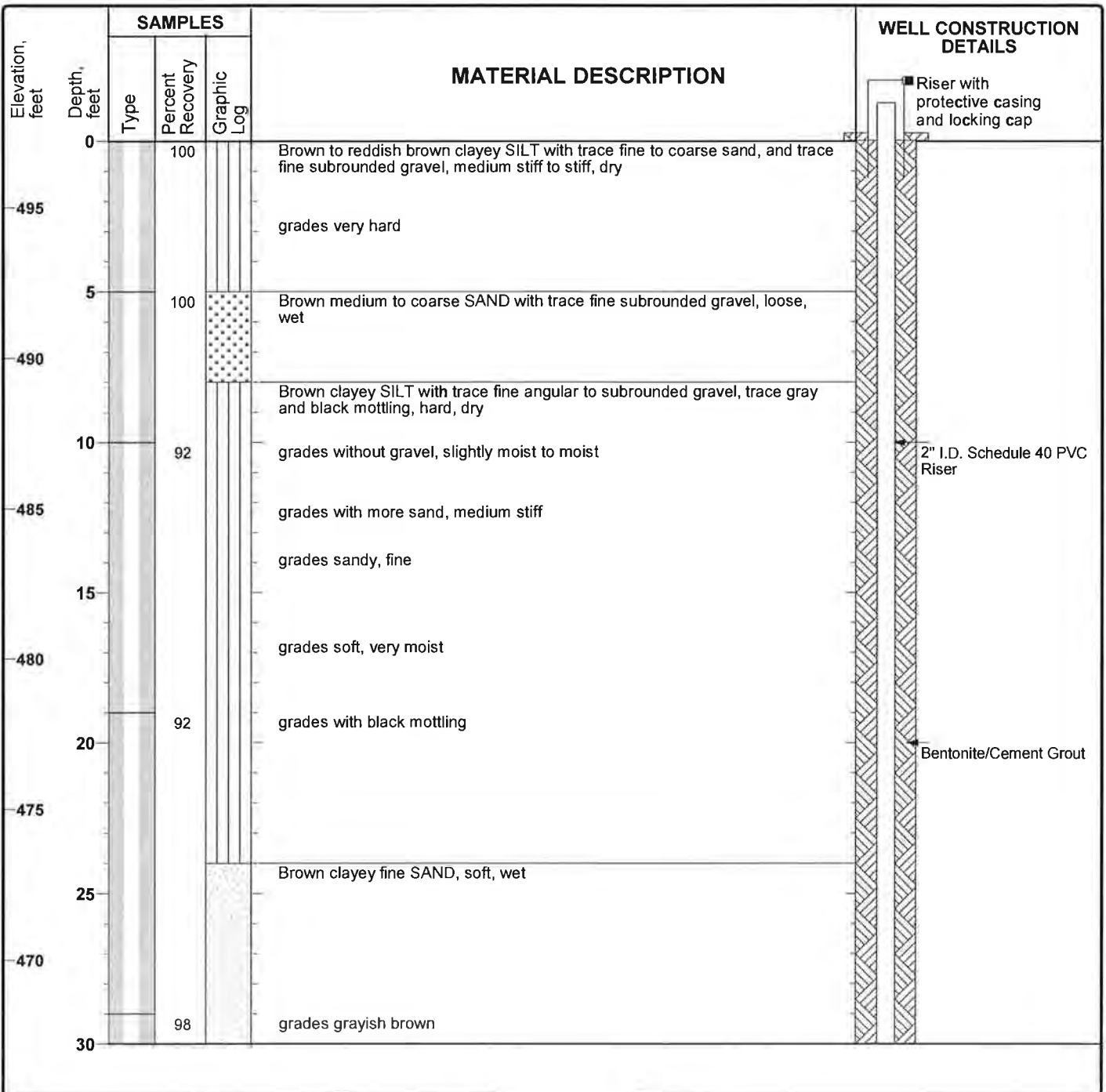

Project: Dynegy  
 Project Location: Zimmer Station  
 Project Number: 60442412

**Monitoring Well  
 MW-13**  
 Sheet 2 of 2

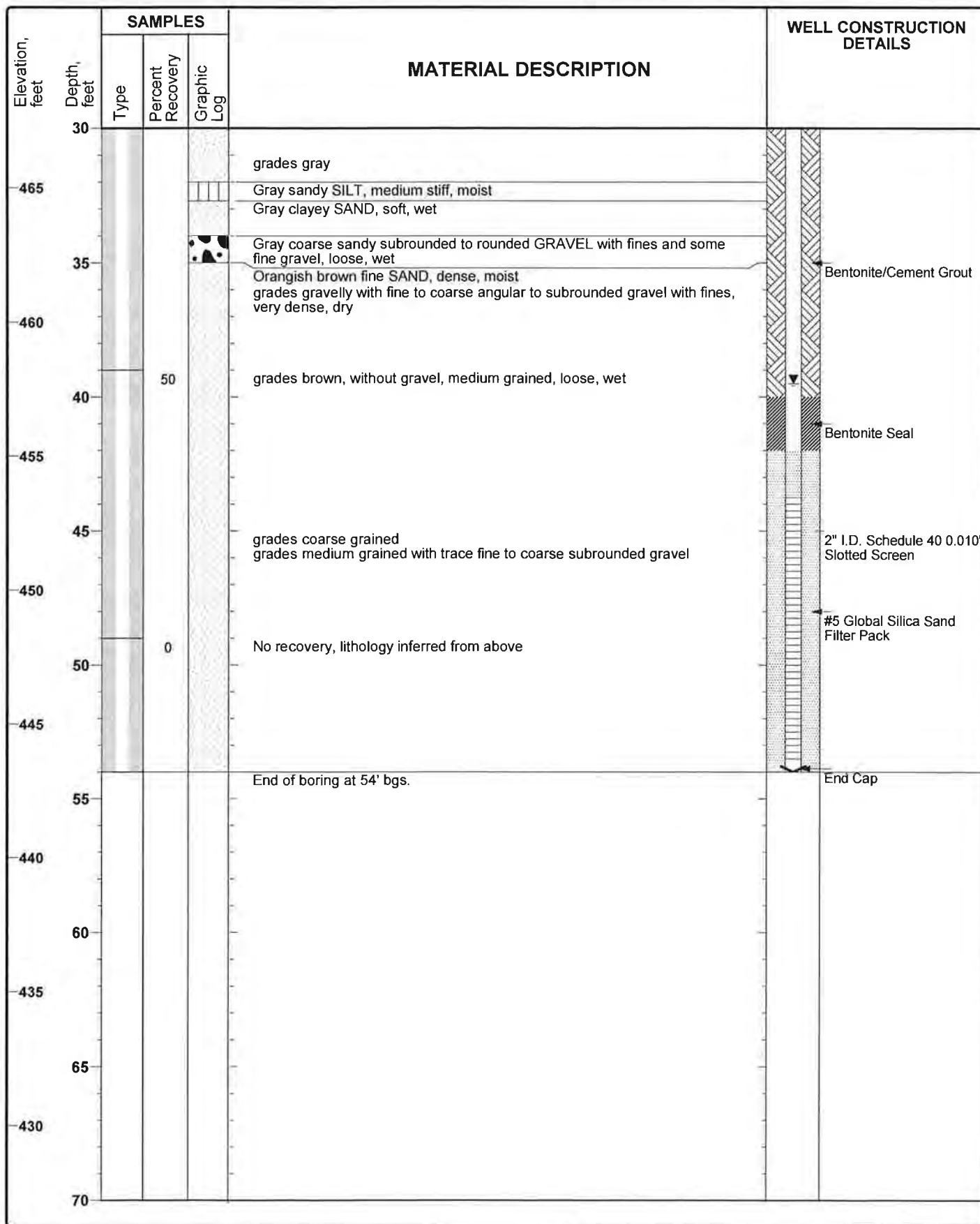

**Project: Dynegy**  
**Project Location: Zimmer Station**  
**Project Number: 60442412**

**Monitoring Well**  
**MW-14**  
 Sheet 1 of 2

Date(s) Drilled	12/9/15	Logged By	Becky Smolenski	Checked By	Mike Wagner
Drilling Method	Rotosonic	Drilling Contractor	Frontz Drilling	Total Depth of Borehole	60.0 feet
Date of Groundwater Measurement	12/18/15	Sampler Type	Sonic Sleeve	Surface Elevation	502.06 feet, msl
Depth to Groundwater	46.27 ft bgs	Seal Material	Hydrated 3/8-inch Bentonite Chips	Top of PVC Elevation	503.81 feet, msl
Diameter of Hole (inches)	6.0	Diameter of Well (inches)	2	Type of Well Casing	Schedule 40 PVC
Type of Sand Pack	#5 Silica Sand	Well Completion at Ground Surface	Riser, With locking cap and protective casing.		
Comments					

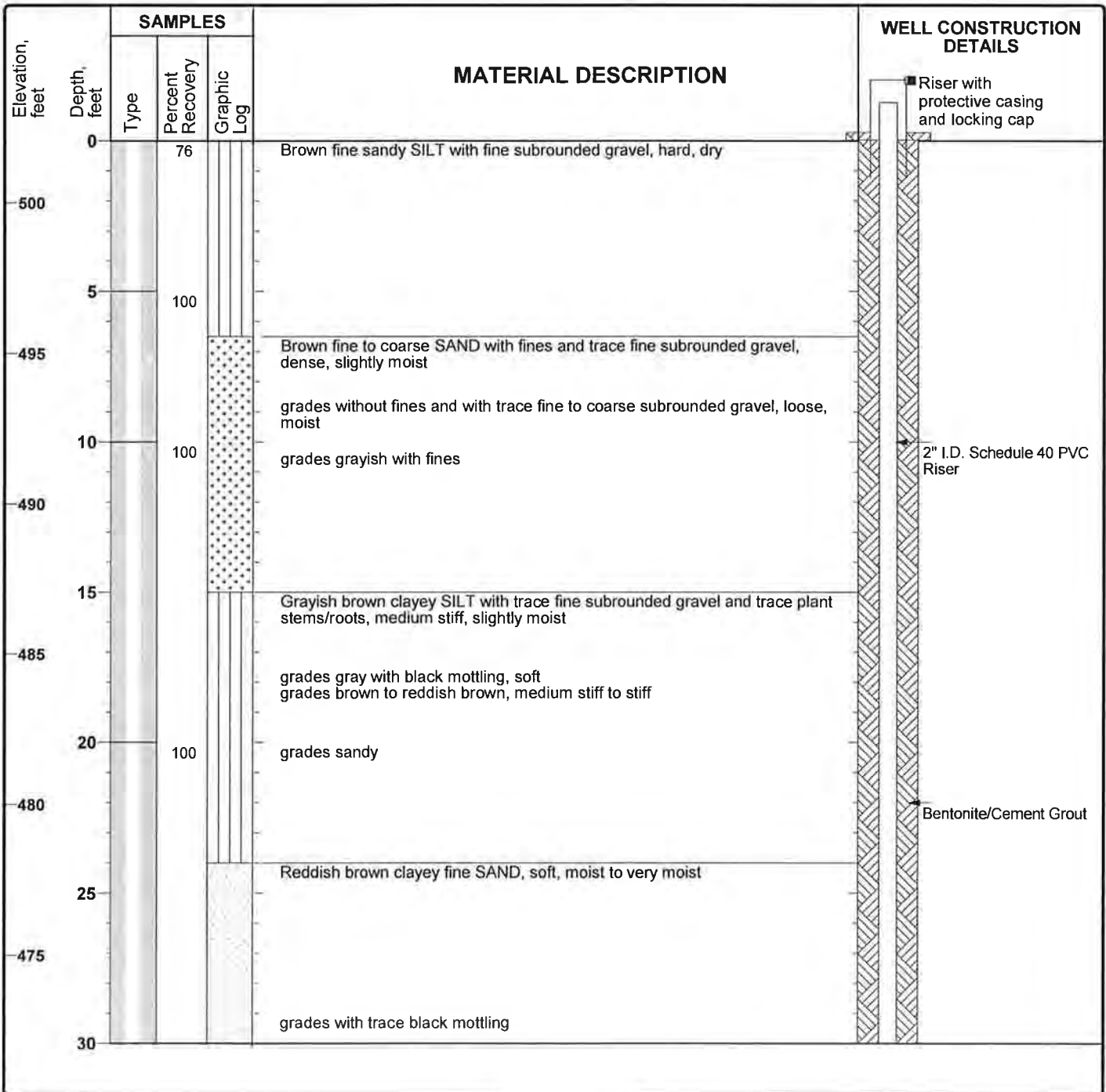

**Project: Dynegy**  
**Project Location: Zimmer Station**  
**Project Number: 60442412**

**Monitoring Well**  
**MW-14**  
 Sheet 2 of 2

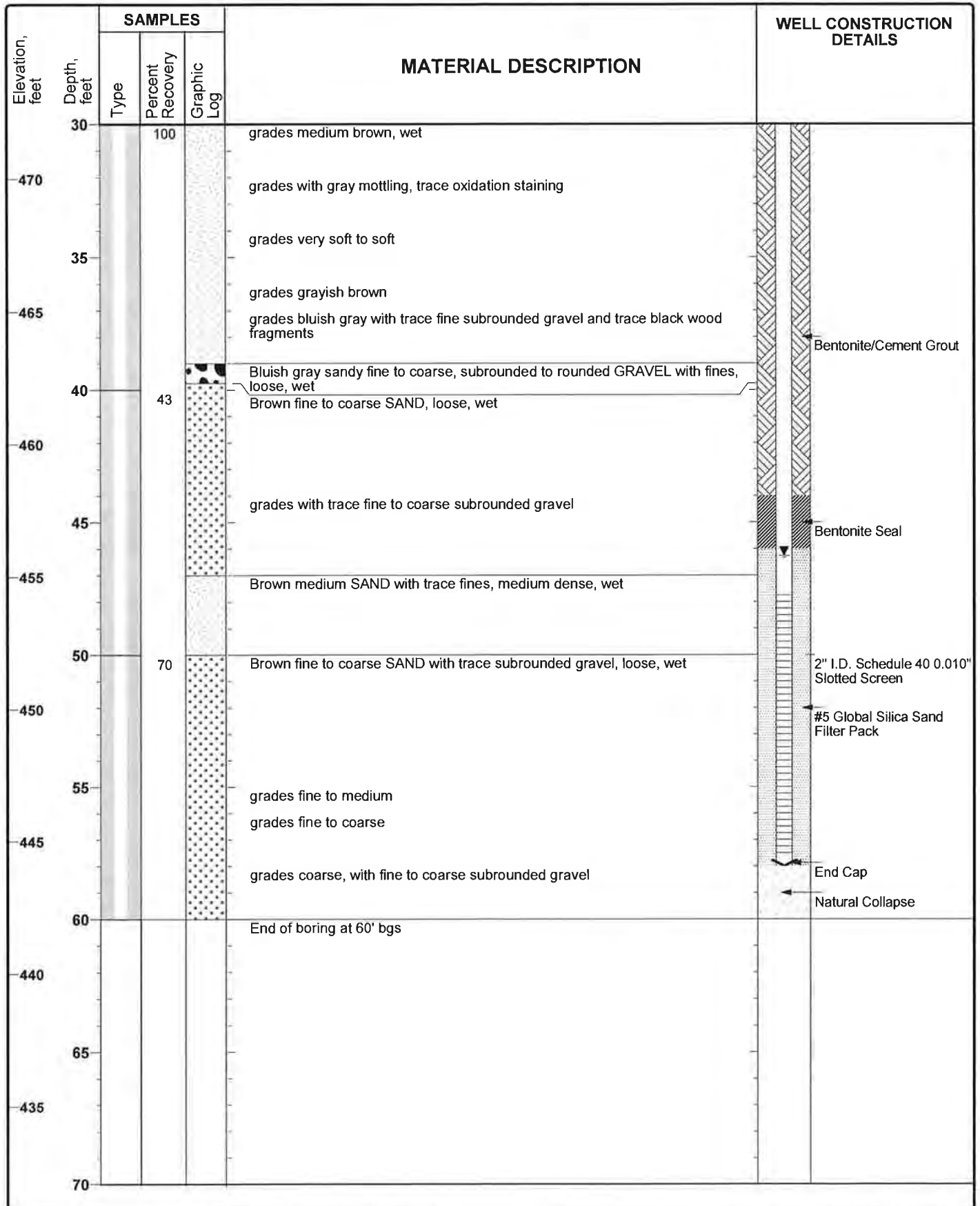

**Project: Dynegy**  
**Project Location: Zimmer Station**  
**Project Number: 60442412**

**Monitoring Well**  
**MW-15**  
 Sheet 1 of 2

Date(s) Drilled	11/25/15	Logged By	Becky Smolenski	Checked By	Mike Wagner
Drilling Method	Rotosonic	Drilling Contractor	Frontz Drilling	Total Depth of Borehole	62.0 feet
Date of Groundwater Measurement	12/18/15	Sampler Type	Sonic Sleeve	Surface Elevation	508.04 feet, msl
Depth to Groundwater	52.77 ft bgs	Seal Material	Hydrated 3/8-inch Bentonite Chips	Top of PVC Elevation	510.58 feet, msl
Diameter of Hole (inches)	6.0	Diameter of Well (inches)	2	Type of Well Casing	Schedule 40 PVC
Type of Sand Pack	#5 Silica Sand	Well Completion at Ground Surface	Riser, With locking cap and protective casing.		
Comments					

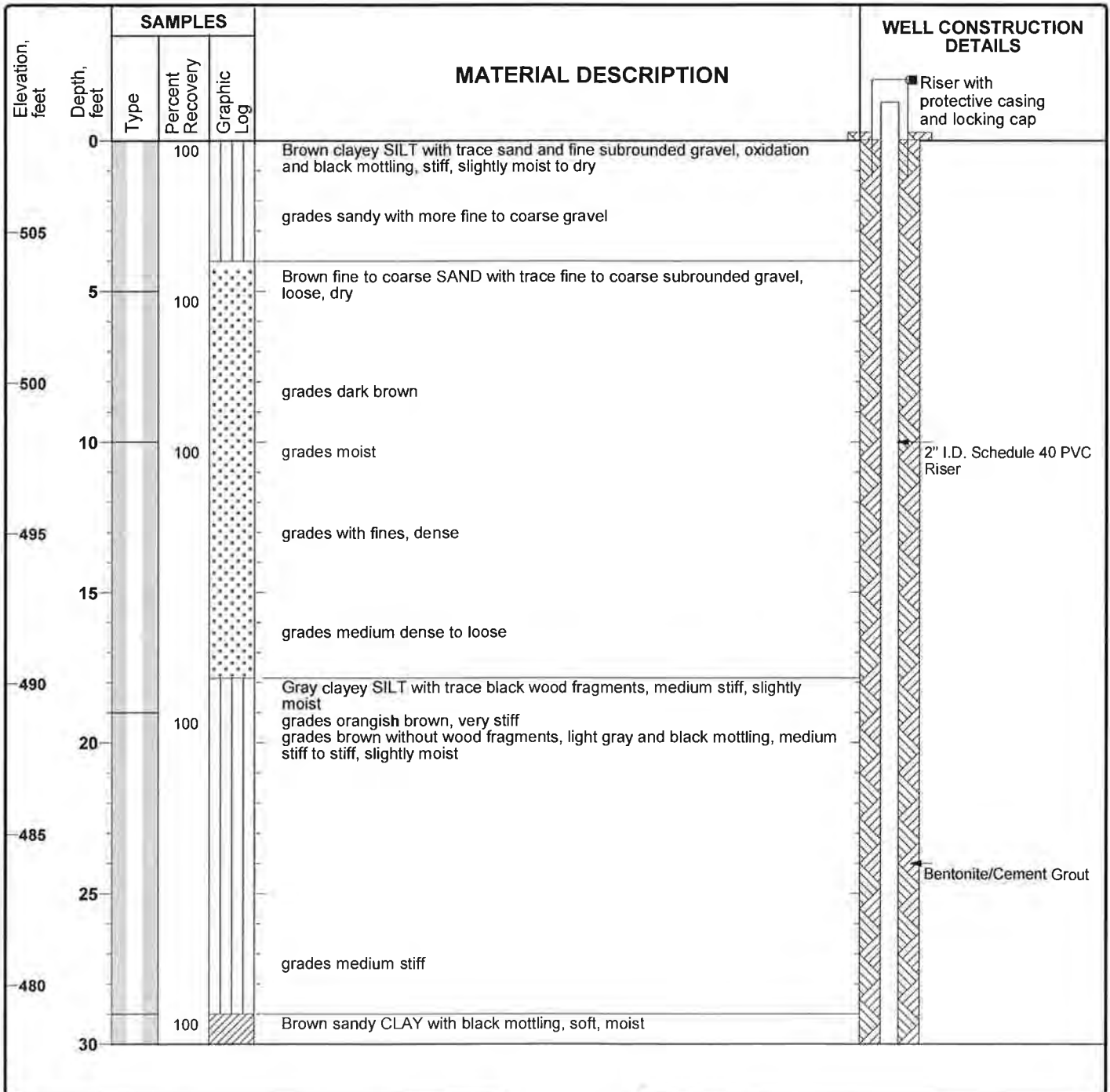



**Project: Dynegy**  
**Project Location: Zimmer Station**  
**Project Number: 60442412**

**Monitoring Well**  
**MW-15**  
 Sheet 2 of 2

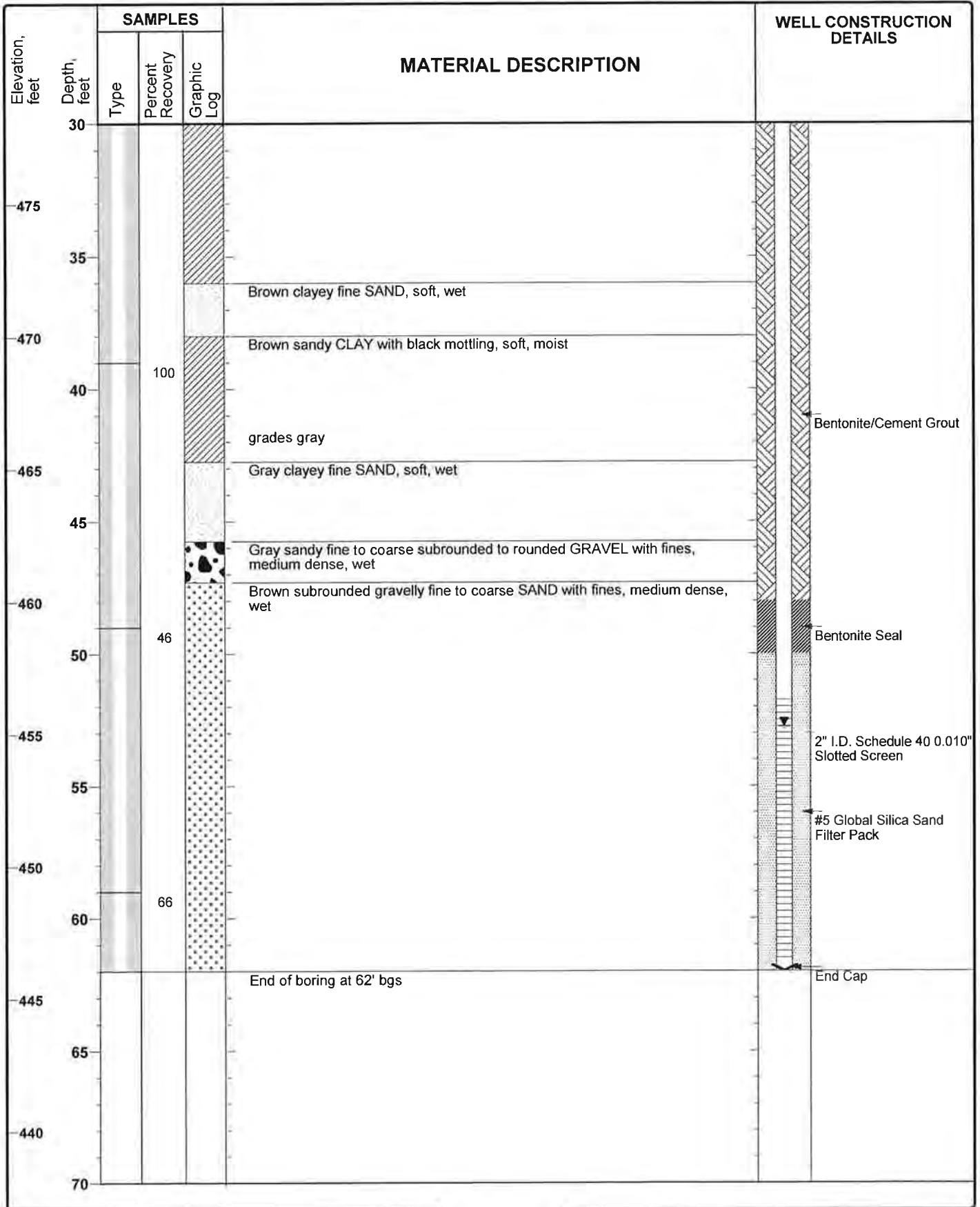

DYNEGY ZIMMER ZIMMER STATION CCR WELLS GPJ 4/19/16

JOB NO. \_\_\_\_\_  
 COMPANY Zimmer Plant  
 PROJECT \_\_\_\_\_  
 COORDINATES N-5940 W-520  
 DATE 5/2/89 TIME \_\_\_\_\_

**WELL CONSTRUCTION  
 SUMMARY ELEVATIONS  
 (FLNGVD)**

WELL No. 1  
 REF. DATUM PT. 511.8  
 Renamed MW-1  
 GRADE 509.9

1. GROUT SEAL Volclay Group  
509.9 to 470.9
2. BENTONITE SEAL
3. SCREEN 20' x 2" x .02 PVC
4. GRAVEL PACK natural sand
5. N. A.
6. RISER PIPE 2" PVC

Water level 470.5  
 5/2/89

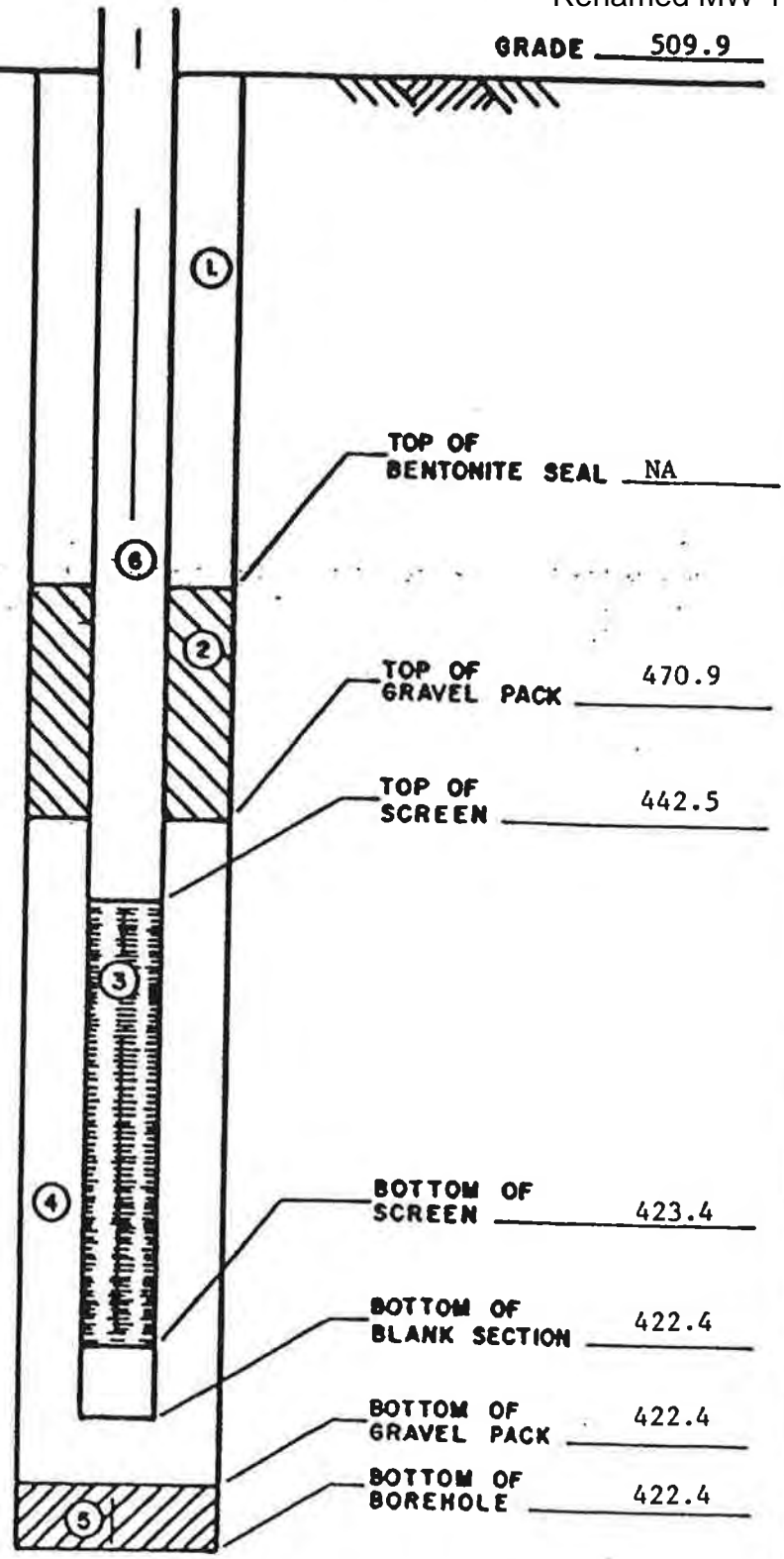

GEOTECHNICAL ENGINEERING SECTION CIVIL DESIGN STANDARD		REVISION		OBSERVATION WELL	
APPROVED	DR.	CH.	_____	_____	
AMERICAN ELECTRIC POWER SVC. CORP.				CDS-04	SH.

Job No. \_\_\_\_\_

COMPANY Zimmer Plant

PROJECT Flood plain monitoring well

COORDINATES N-3270 E-130

DATE 4/26/89 TIME \_\_\_\_\_

WELL CONSTRUCTION  
SUMMARY ELEVATIONS  
(ft. NGVD)

WELL No. 8  
REF. DATUM PT. 513.1

Renamed MW-8

GRADE 511.1

1. GROUT SEAL Volclay Grout  
511.1 to 441.0
2. BENTONITE SEAL
3. SCREEN 20' x 2" x .02 PVC
4. GRAVEL PACK natural sand
5. N. A.
6. RISER PIPE 2" PVC

Water level 4/27/89, 18 hrs.  
Elevation 464.4

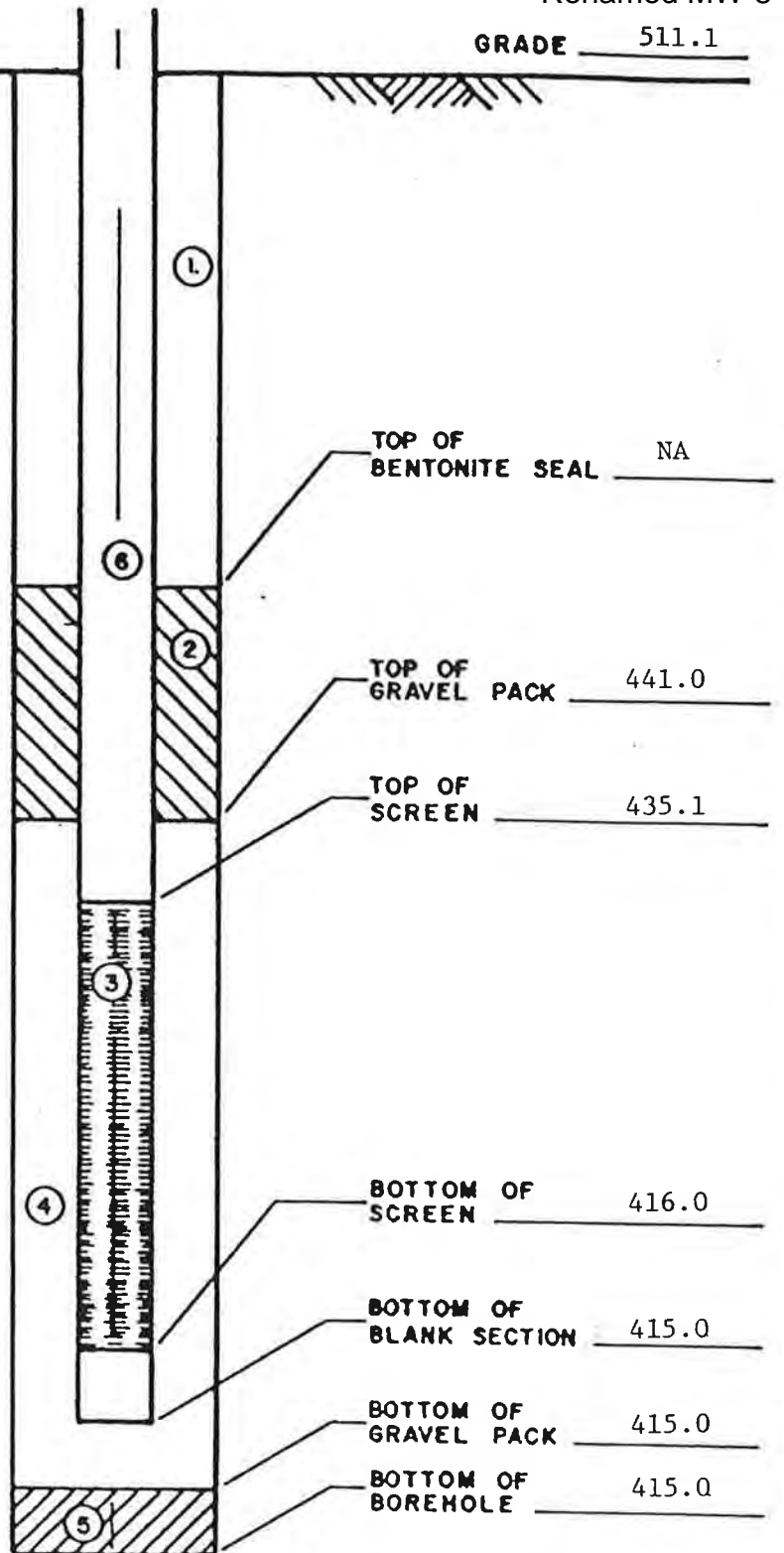

GEOTECHNICAL ENGINEERING SECTION  
CIVIL DESIGN STANDARD

REVISION

OBSERVATION  
WELL

APPROVED

DR.

CH.

AMERICAN ELECTRIC POWER SVC. CORP.

CDS-04

SH.

**APPENDIX C3 – MAPS OF THE DIRECTION OF GROUNDWATER FLOW**







J:\Project\ID\dynegy\60442412 Miami Fort and Zimmer CCR 2015-2017\Data-Tech\TIV\MZ\IM\PIEZ\local\_pile\_fig1\_9-16.ai

← Ohio River  
Stable River Conditions

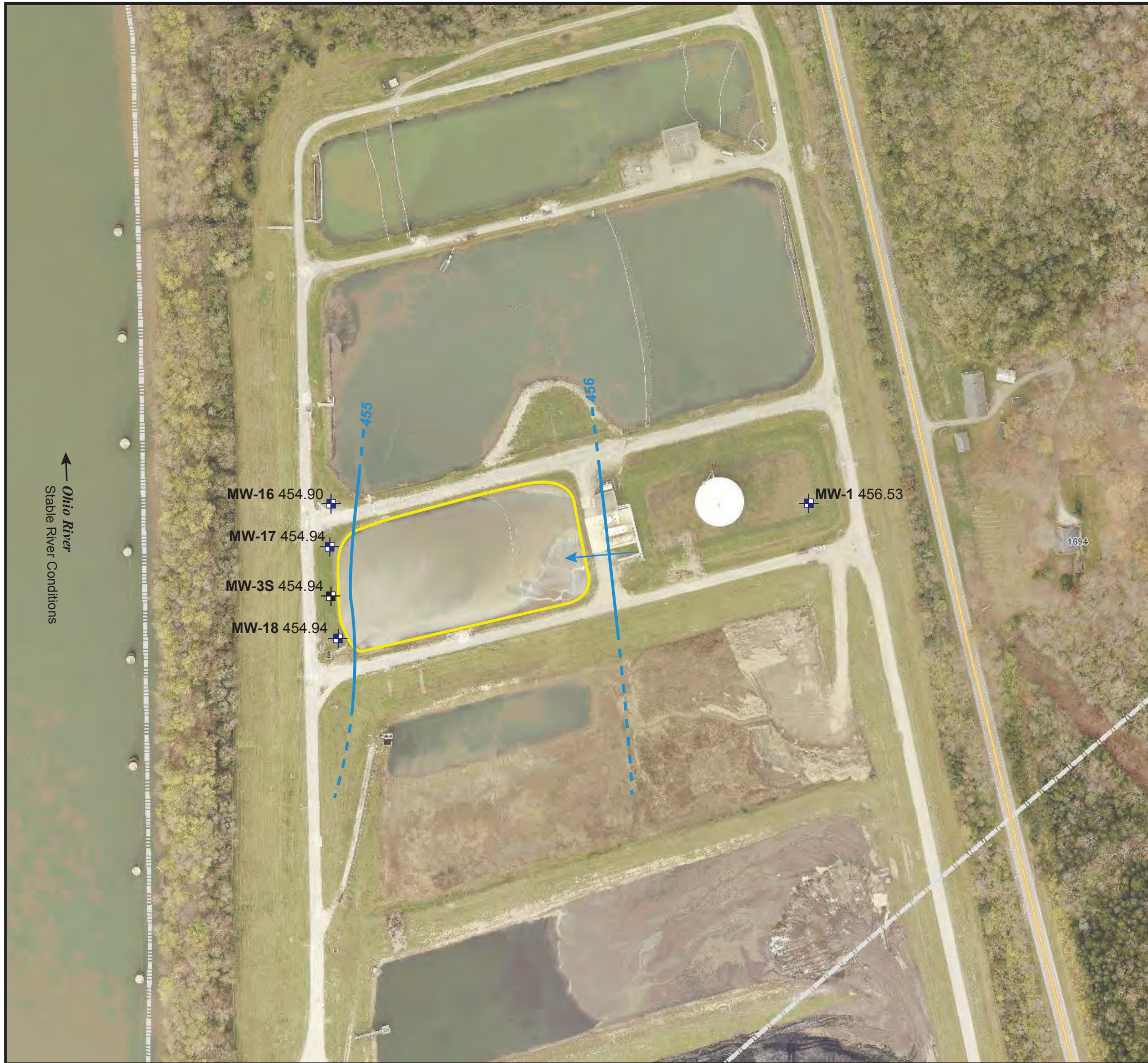

- UNIT BOUNDARY
- + EXISTING MONITORING WELL LOCATION
- + DOWNGRAIDENT MONITORING WELL LOCATION
- WATER TABLE CONTOUR  
(INFERRED FROM AVAILABLE MONITORING DATA)
- GROUNDWATER FLOW DIRECTION
- 456.53 GROUNDWATER ELEVATION (FEET, MSL),  
MEASURED SEPTEMBER 26, 2016

AERIAL SOURCE: CLERMONT COUNTY, OH GIS

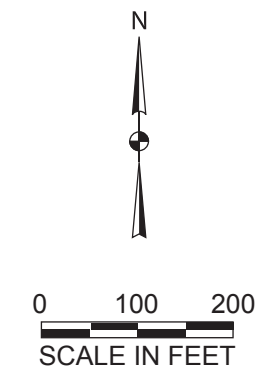

Certified By:



Zimmer Station  
Clermont County, Ohio

FIGURE 1  
GROUNDWATER SURFACE MAP-  
SEPTEMBER 26, 2016  
COAL PILE RUNOFF POND (UNIT ID: 125)  
CCR SAMPLING AND ANALYSIS PLAN

SIGNATURE \_\_\_\_\_  
DATE \_\_\_\_\_

DATE	REV NO.	DWG. BY	CHKD. BY
12/15/16	0	ALW	MAW

JOB NO. 60442412









J:\Project\DYnegy\60442412 Miami Fort and Zimmer CCR 2015-2017\Data-Tech\TIZIMIZIM PIEZCOAL pile fig1\_11-16.ai

Ohio River  
Stable River Conditions



- UNIT BOUNDARY
- + EXISTING MONITORING WELL LOCATION
- + DOWNGRAIDENT MONITORING WELL LOCATION
- WATER TABLE CONTOUR  
(INFERRED FROM AVAILABLE MONITORING DATA)
- GROUNDWATER FLOW DIRECTION
- 456.65 GROUNDWATER ELEVATION (FEET, MSL),  
MEASURED NOVEMBER 16, 2016

AERIAL SOURCE: CLERMONT COUNTY, OH GIS

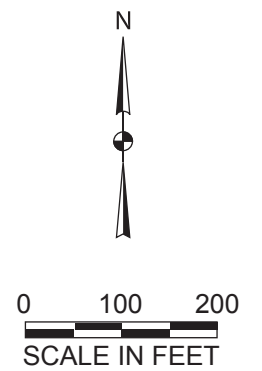

Certified By:

 Zimmer Station  
Clermont County, Ohio

**FIGURE 1**  
**GROUNDWATER SURFACE MAP-**  
**NOVEMBER 16, 2016**  
**COAL PILE RUNOFF POND (UNIT ID: 125)**  
**CCR SAMPLING AND ANALYSIS PLAN**

DATE	REV NO.	DWG. BY	CHKD. BY
12/16/16	0	ALW	MAW

SIGNATURE \_\_\_\_\_  
 DATE \_\_\_\_\_

JOB NO. 60442412 **AECOM**



J:\Project\DYnegy\60442412 Miami Fort and Zimmer CCR 2015-2017\Data-Tech\T1\ZIMZIM\_PIEZlocal\_pile\_fig1\_12-16.ai

← **Ohio River**  
Short-term Falling River Stage during  
Long-term Rising River Conditions



- UNIT BOUNDARY
- + EXISTING MONITORING WELL LOCATION
- + DOWNGRADIENT MONITORING WELL LOCATION
- WATER TABLE CONTOUR  
(INFERRED FROM AVAILABLE MONITORING DATA)
- GROUNDWATER FLOW DIRECTION
- 456.88 GROUNDWATER ELEVATION (FEET, MSL),  
MEASURED DECEMBER 12, 2016

AERIAL SOURCE: CLERMONT COUNTY, OH GIS

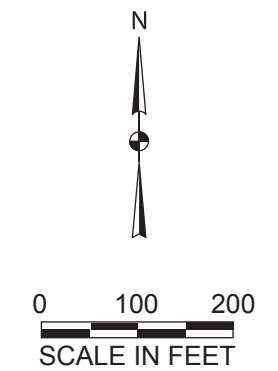

Certified By: _____  SIGNATURE _____ DATE _____	Zimmer Station Clermont County, Ohio	<b>FIGURE 1</b> GROUNDWATER SURFACE MAP- DECEMBER 12, 2016 COAL PILE RUNOFF POND (UNIT ID: 125) CCR SAMPLING AND ANALYSIS PLAN								
<table border="1" style="width: 100%; border-collapse: collapse;"> <thead> <tr> <th style="width: 25%;">DATE</th> <th style="width: 25%;">REV NO.</th> <th style="width: 25%;">DWG. BY</th> <th style="width: 25%;">CHKD. BY</th> </tr> </thead> <tbody> <tr> <td>01/05/16</td> <td>0</td> <td>ALW</td> <td>MAW</td> </tr> </tbody> </table>		DATE	REV NO.	DWG. BY	CHKD. BY	01/05/16	0	ALW	MAW	JOB NO. 60442412 
DATE	REV NO.	DWG. BY	CHKD. BY							
01/05/16	0	ALW	MAW							



J:\Project\ID\dynegy\60442412 Miami Fort and Zimmer CCR 2015-2017\Data-Tech\TIV\MZ\MZIM PIEZ\local pile fig1\_3-17.ai

← Ohio River  
Falling river conditions from  
near flood stage

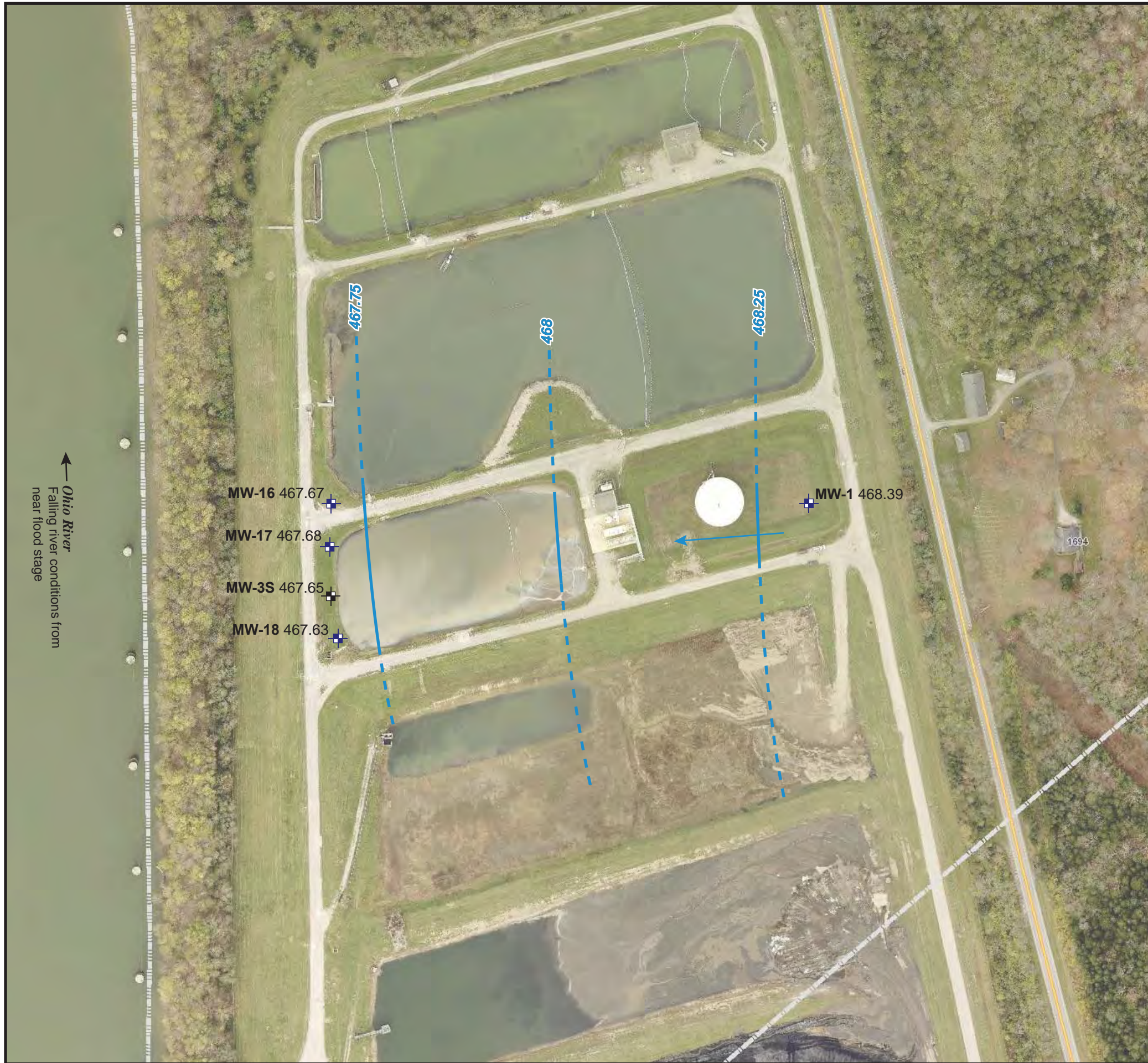

- UNIT BOUNDARY
- ⊕ EXISTING MONITORING WELL LOCATION
- ⊕ DOWNGRAIDENT MONITORING WELL LOCATION
- WATER TABLE CONTOUR  
(INFERRED FROM AVAILABLE MONITORING DATA)
- GROUNDWATER FLOW DIRECTION
- 468.39 GROUNDWATER ELEVATION (FEET, MSL),  
MEASURED MARCH 8, 2017

AERIAL SOURCE: CLERMONT COUNTY, OH GIS

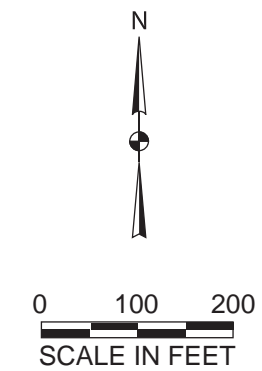

Certified By:



Zimmer Station  
Clermont County, Ohio

FIGURE 1  
GROUNDWATER SURFACE MAP-  
MARCH 8, 2017  
COAL PILE RUNOFF POND (UNIT ID: 125)  
CCR SAMPLING AND ANALYSIS PLAN

SIGNATURE \_\_\_\_\_  
DATE \_\_\_\_\_

DATE	REV NO.	DWG. BY	CHKD. BY
09/07/17	0	ALW	MAW

JOB NO. 60442412







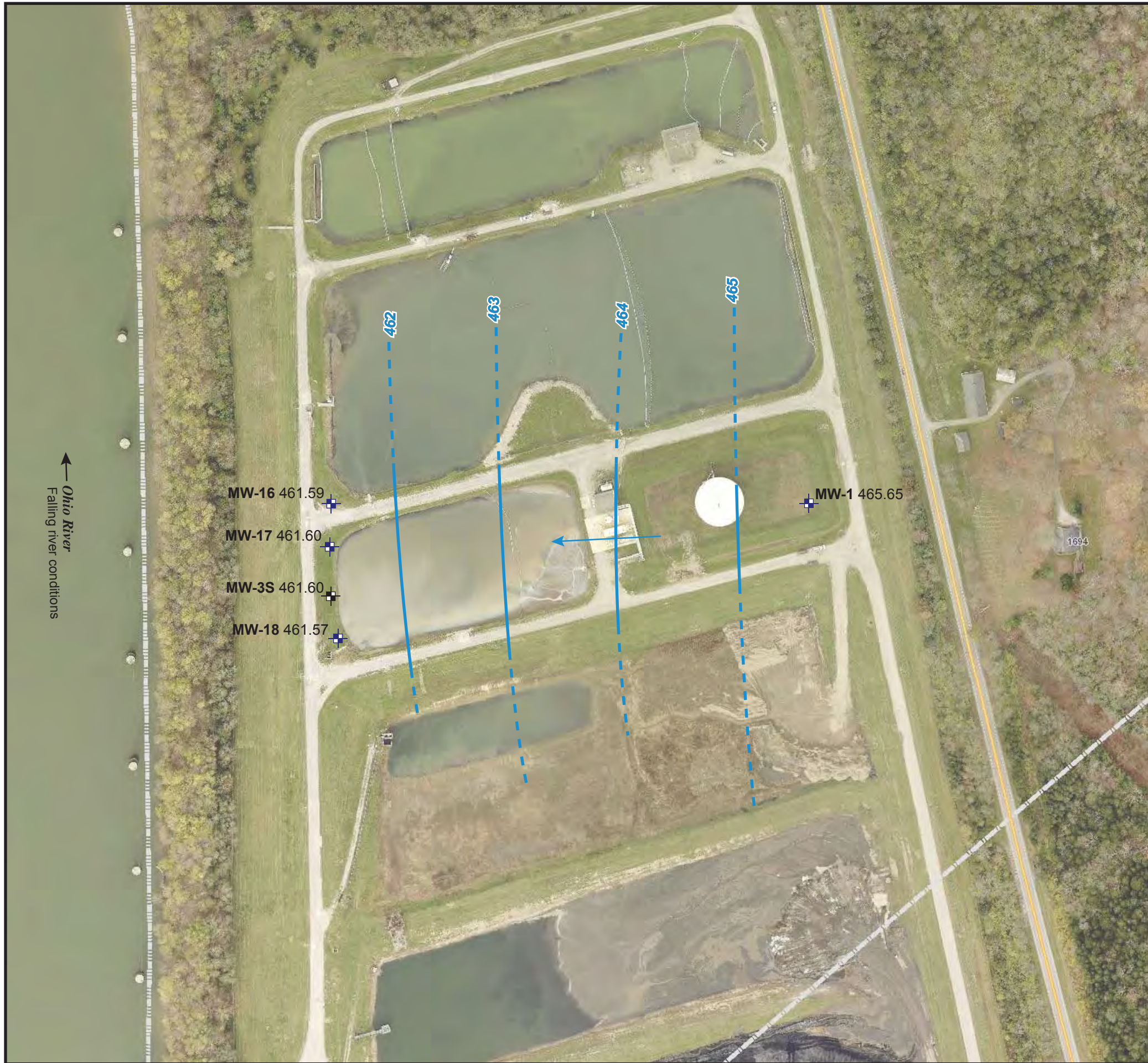

J:\Project\ID\dynegy\60442412 Miami Fort and Zimmer CCR 2015-2017\Data-Tech\TIV\MZ\IM PIEZ\local pile fig\_1\_6-17.ai

← Ohio River  
Falling river conditions



-  UNIT BOUNDARY
-  EXISTING MONITORING WELL LOCATION
-  DOWNGRAIDENT MONITORING WELL LOCATION
-  WATER TABLE CONTOUR  
(INFERRED FROM AVAILABLE MONITORING DATA)
-  GROUNDWATER FLOW DIRECTION
- 465.65 GROUNDWATER ELEVATION (FEET, MSL),  
MEASURED JUNE 8, 2017

AERIAL SOURCE: CLERMONT COUNTY, OH GIS

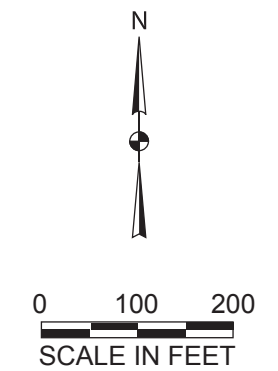

Certified By:

 Zimmer Station  
Clermont County, Ohio

FIGURE 1  
GROUNDWATER SURFACE MAP-  
JUNE 8, 2017  
COAL PILE RUNOFF POND (UNIT ID: 125)  
CCR SAMPLING AND ANALYSIS PLAN

DATE	REV NO.	DWG. BY	CHKD. BY
09/07/17	0	ALW	MAW

SIGNATURE \_\_\_\_\_  
DATE \_\_\_\_\_

JOB NO. 60442412 



J:\Project\IDynegy\60442412 Miami Fort and Zimmer CCR 2015-2017\Data-Tech\TIV\TIV\MZ\IM\PIEZ\local pile fig1\_7-17.ai

← Ohio River  
Stable river conditions



- UNIT BOUNDARY
- ⊕ EXISTING MONITORING WELL LOCATION
- ⊕ DOWNGRAIDENT MONITORING WELL LOCATION
- WATER TABLE CONTOUR  
(INFERRED FROM AVAILABLE MONITORING DATA)
- GROUNDWATER FLOW DIRECTION
- 462.42 GROUNDWATER ELEVATION (FEET, MSL),  
MEASURED JULY 13, 2017

AERIAL SOURCE: CLERMONT COUNTY, OH GIS

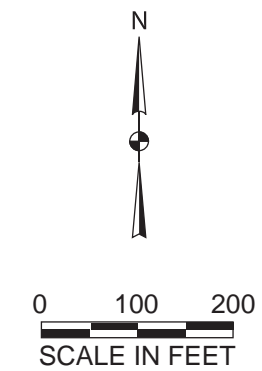

Certified By:



Zimmer Station  
Clermont County, Ohio

FIGURE 1  
GROUNDWATER SURFACE MAP-  
JULY 13, 2017  
COAL PILE RUNOFF POND (UNIT ID: 125)  
CCR SAMPLING AND ANALYSIS PLAN

SIGNATURE \_\_\_\_\_  
DATE \_\_\_\_\_

DATE	REV NO.	DWG. BY	CHKD. BY
09/07/17	0	ALW	MAW

JOB NO. 60442412





Service Layer Credits: Source: Esri, Maxar, GeoEye, Earthstar Geographics, CNES/Airbus DS, USDA, USGS, AeroGRID, IGN, and the GIS User Community



- CCR MONITORING WELL LOCATION
- GROUNDWATER ELEVATION CONTOUR (1-FT CONTOUR INTERVAL, FT MSL)
- INFERRED GROUNDWATER ELEVATION CONTOUR
- GROUNDWATER FLOW DIRECTION
- CCR MONITORED UNIT

ZIMMER D BASIN (UNIT ID: 121) AND  
 ZIMMER COAL PILE RUNOFF POND (UNIT ID: 125)  
 GROUNDWATER ELEVATION CONTOUR MAP  
 NOVEMBER 13, 2017

CCR RULE GROUNDWATER MONITORING  
 ZIMMER POWER STATION  
 MOSCOW, OHIO

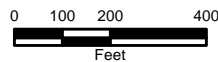

Service Layer Credits: Source: Esri, Maxar, GeoEye, Earthstar Geographics, CNES/Airbus DS, USDA, USGS, AeroGRID, IGN, and the GIS User Community



- CCR MONITORING WELL LOCATION
- GROUNDWATER ELEVATION CONTOUR (1-FT CONTOUR INTERVAL, FT MSL)
- INFERRED GROUNDWATER ELEVATION CONTOUR
- GROUNDWATER FLOW DIRECTION
- CCR MONITORED UNIT

ZIMMER D BASIN (UNIT ID: 121) AND  
 ZIMMER COAL PILE RUNOFF POND (UNIT ID: 125)  
 GROUNDWATER ELEVATION CONTOUR MAP  
 MAY 7-9, 2018

CCR RULE GROUNDWATER MONITORING  
 ZIMMER POWER STATION  
 MOSCOW, OHIO

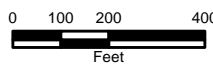



Service Layer Credits: Source: Esri, Maxar, GeoEye, Earthstar Geographics, CNES/Airbus DS, USDA, USGS, AeroGRID, IGN, and the GIS User Community



- CCR MONITORING WELL LOCATION
- GROUNDWATER ELEVATION CONTOUR (1-FT CONTOUR INTERVAL, FT MSL)
- INFERRED GROUNDWATER ELEVATION CONTOUR
- GROUNDWATER FLOW DIRECTION
- CCR MONITORED UNIT

ZIMMER D BASIN (UNIT ID: 121) AND  
ZIMMER COAL PILE RUNOFF POND (UNIT ID: 125)  
GROUNDWATER ELEVATION CONTOUR MAP  
SEPTEMBER 18, 2018

CCR RULE GROUNDWATER MONITORING  
ZIMMER POWER STATION  
MOSCOW, OHIO

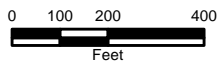

Service Layer Credits: Source: Esri, Maxar, GeoEye, Earthstar Geographics, CNES/Airbus DS, USDA, USGS, AeroGRID, IGN, and the GIS User Community

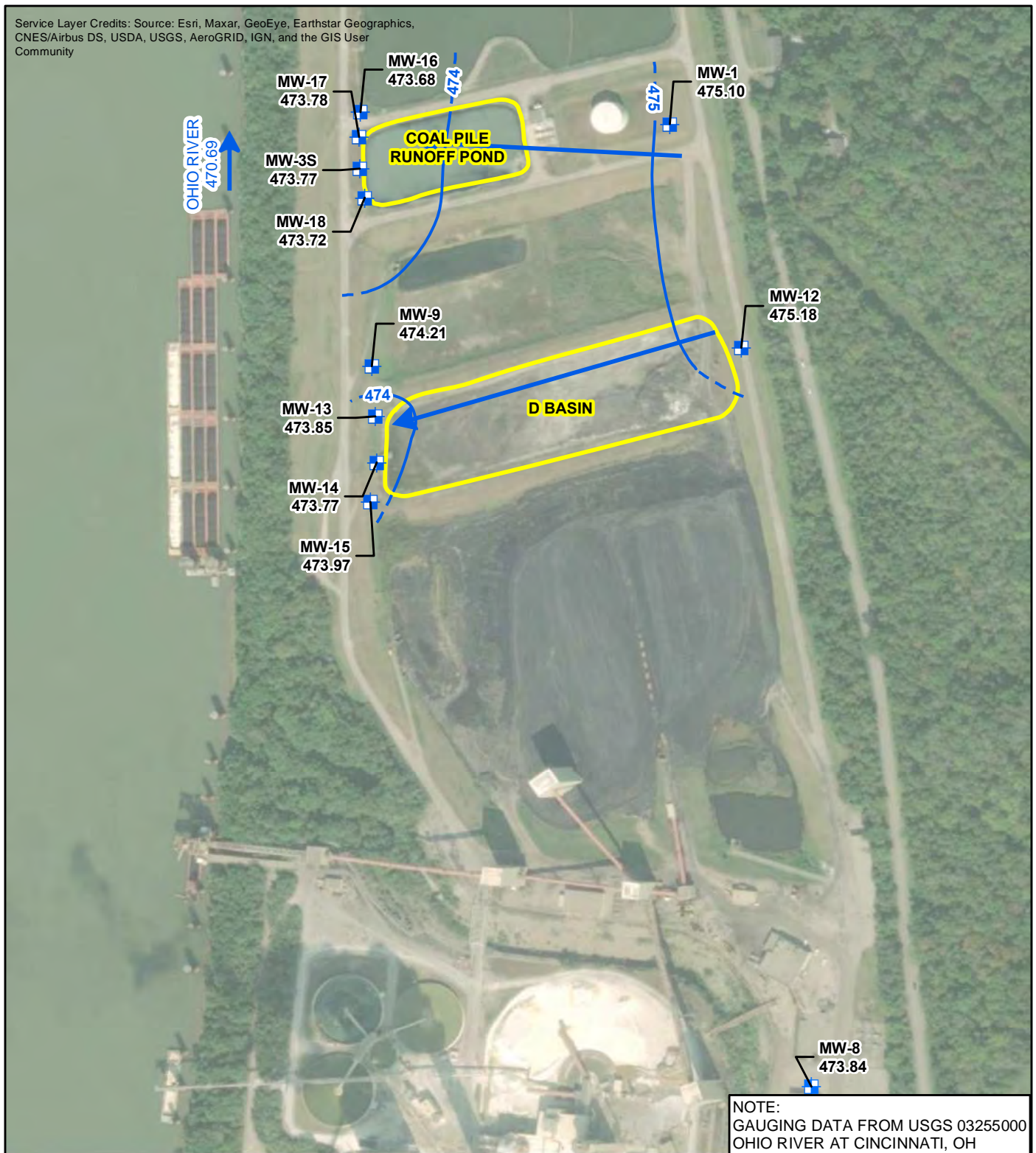

NOTE:  
 GAUGING DATA FROM USGS 03255000  
 OHIO RIVER AT CINCINNATI, OH

- CCR MONITORING WELL LOCATION
- GROUNDWATER ELEVATION CONTOUR (1-FT CONTOUR INTERVAL, FT MSL)
- INFERRED GROUNDWATER ELEVATION CONTOUR
- GROUNDWATER FLOW DIRECTION
- CCR MONITORED UNIT

ZIMMER D BASIN (UNIT ID: 121) AND  
 ZIMMER COAL PILE RUNOFF POND (UNIT ID: 125)  
 GROUNDWATER ELEVATION CONTOUR MAP  
 MARCH 13, 2019





CCR RULE GROUNDWATER MONITORING  
 ZIMMER POWER STATION  
 MOSCOW, OHIO





Service Layer Credits: Source: Esri, Maxar, GeoEye, Earthstar Geographics, CNES/Airbus DS, USDA, USGS, AeroGRID, IGN, and the GIS User Community



-  CCR MONITORING WELL LOCATION
-  GROUNDWATER ELEVATION CONTOUR (1-FT CONTOUR INTERVAL, FT MSL)
-  INFERRED GROUNDWATER ELEVATION CONTOUR
-  GROUNDWATER FLOW DIRECTION
-  CCR MONITORED UNIT

ZIMMER D BASIN (UNIT ID: 121) AND  
ZIMMER COAL PILE RUNOFF POND (UNIT ID: 125)  
GROUNDWATER ELEVATION CONTOUR MAP  
SEPTEMBER 10, 2019

CCR RULE GROUNDWATER MONITORING  
ZIMMER POWER STATION  
MOSCOW, OHIO

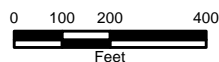

O'BRIEN & GERE ENGINEERS, INC.



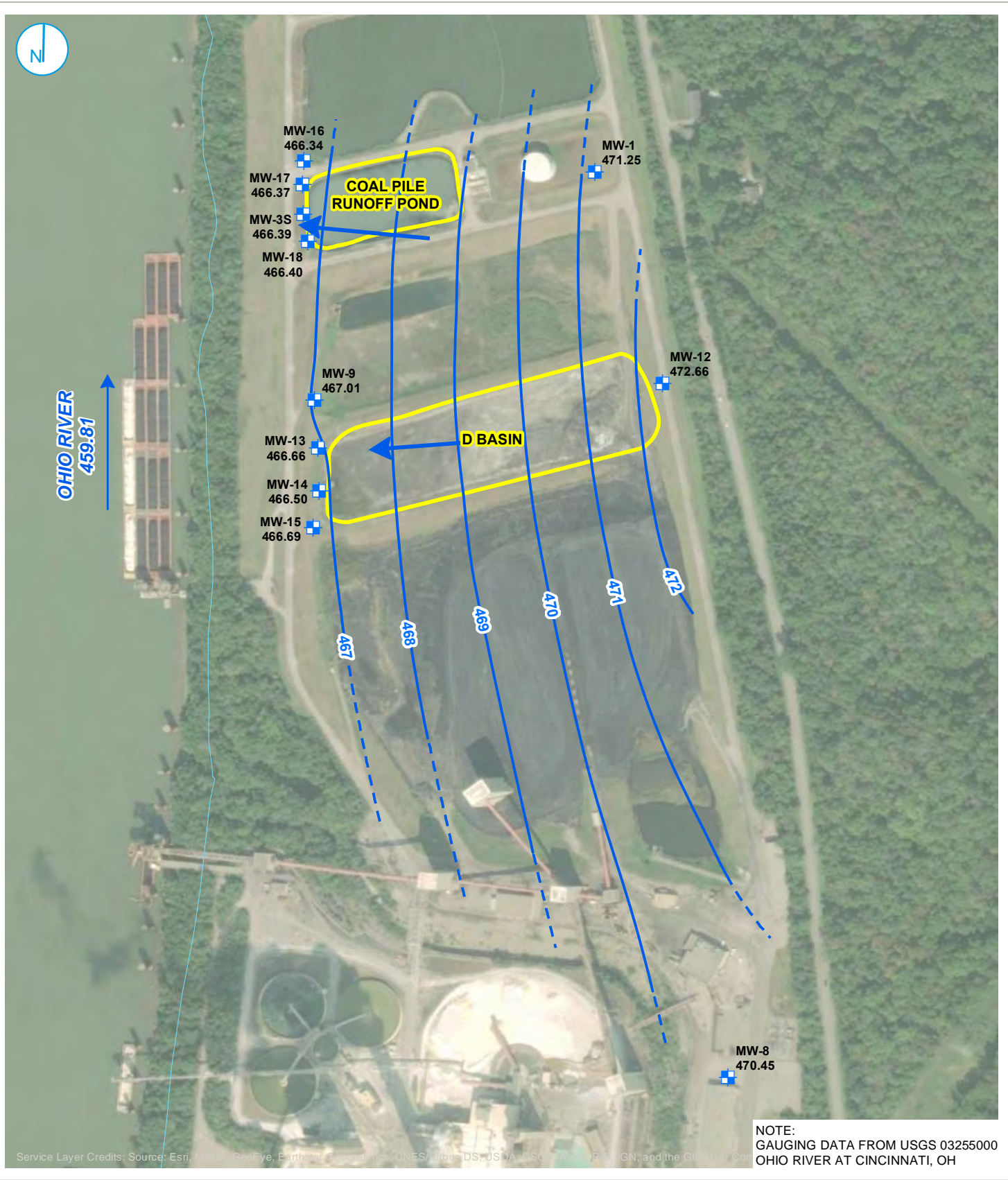

NOTE:  
GAUGING DATA FROM USGS 03255000  
OHIO RIVER AT CINCINNATI, OH

- CCR MONITORING WELL LOCATION
- GROUNDWATER ELEVATION CONTOUR (1-FT CONTOUR INTERVAL, FT MSL)
- INFERRED GROUNDWATER ELEVATION CONTOUR
- GROUNDWATER FLOW DIRECTION
- SURFACE WATER FEATURE
- CCR MONITORED UNIT



## GROUNDWATER ELEVATION CONTOUR MAP APRIL 9, 2020

ZIMMER D BASIN (UNIT ID: 121) AND  
ZIMMER COAL PILE RUNOFF POND (UNIT ID: 125)  
ZIMMER POWER STATION  
MOSCOW, OHIO

RAMBOLL US CORPORATION  
A RAMBOLL COMPANY





J:\Project\DYnegy\60442412 Miami Fort and Zimmer CCR 2015-2017\Data-Tech\T\ZIM\ZIM\_PIEZ\gyp\_recy\_pond\_fig1\_12-15.ai



- UNIT BOUNDARY
- + DOWNGRADIENT MONITORING WELL LOCATION
- + UPGRADIENT MONITORING WELL LOCATION
- WATER TABLE CONTOUR  
(INFERRED FROM AVAILABLE MONITORING DATA)
- GROUNDWATER FLOW DIRECTION
- 462.56 GROUNDWATER ELEVATION (FEET, MSL),  
MEASURED DECEMBER 29, 2015

NOTE- RISING OHIO RIVER CONDITIONS TO  
NEAR FLOOD STAGE

AERIAL SOURCE: CAGIS



0 40 80  
SCALE IN FEET

Certified By:



Zimmer Station  
Clermont County, Ohio

FIGURE 1  
GROUNDWATER SURFACE MAP-  
DECEMBER 29, 2015  
GYPSUM RECYCLING POND (UNIT ID: 124)  
CCR SAMPLING AND ANALYSIS PLAN

SIGNATURE \_\_\_\_\_  
DATE \_\_\_\_\_

DATE	REV NO.	DWG. BY	CHKD. BY
08/04/16	0	ALW	MAW

JOB NO. 60442412





J:\Project\DYnegy\60442412 Miami Fort and Zimmer CCR 2015-2017\Data-Tech\TIZIMIZIM PIEZlogyp recy pond fig\_3-16.ai



- UNIT BOUNDARY
- + DOWNGRADIENT MONITORING WELL LOCATION
- + UPGRADIENT MONITORING WELL LOCATION
- WATER TABLE CONTOUR  
(INFERRED FROM AVAILABLE MONITORING DATA)
- GROUNDWATER FLOW DIRECTION
- 468.40 GROUNDWATER ELEVATION (FEET, MSL),  
MEASURED MARCH 16, 2016

NOTE- RAPID RISING OHIO RIVER CONDITIONS FOLLOWING  
RAPID DECENDING CONDITIONS FROM NEAR FLOOD STAGE

AERIAL SOURCE: CAGIS



Certified By:



Zimmer Station  
Clermont County, Ohio

FIGURE 1  
GROUNDWATER SURFACE MAP-  
MARCH 16, 2016  
GYPSUM RECYCLING POND (UNIT ID: 124)  
CCR SAMPLING AND ANALYSIS PLAN

SIGNATURE \_\_\_\_\_  
DATE \_\_\_\_\_

DATE	REV NO.	DWG. BY	CHKD. BY
08/04/16	0	ALW	MAW

JOB NO. 60442412 **AECOM**



J:\Project\DYnegy\60442412 Miami Fort and Zimmer CCR 2015-2017\Data-Tech\TIZIMIZIM PIEZIGYP recy pond fig\_6-16.ai



- UNIT BOUNDARY
- + DOWNGRADE MONITORING WELL LOCATION
- + UPGRADIENT MONITORING WELL LOCATION
- WATER TABLE CONTOUR  
(INFERRED FROM AVAILABLE MONITORING DATA)
- GROUNDWATER FLOW DIRECTION
- 461.68 GROUNDWATER ELEVATION (FEET, MSL),  
MEASURED JUNE 15, 2016

NOTE- STABLE OHIO RIVER CONDITIONS

AERIAL SOURCE: CAGIS



Certified By:



Zimmer Station  
Clermont County, Ohio

FIGURE 1  
GROUNDWATER SURFACE MAP-  
JUNE 15, 2016  
GYPSUM RECYCLING POND (UNIT ID: 124)  
CCR SAMPLING AND ANALYSIS PLAN

SIGNATURE \_\_\_\_\_  
DATE \_\_\_\_\_

DATE	REV NO.	DWG. BY	CHKD. BY
08/04/16	0	ALW	MAW

JOB NO. 60442412 **AECOM**



J:\Project\DYNEGY\60442412 Miami Fort and Zimmer CCR 2015-2017\Data-Tech\TIZIMIZIM PIEZIGYP recy pond fig\_9-16.ai



- UNIT BOUNDARY
- + DOWNGRADE MONITORING WELL LOCATION
- + UPGRADIENT MONITORING WELL LOCATION
- WATER TABLE CONTOUR  
(INFERRED FROM AVAILABLE MONITORING DATA)
- GROUNDWATER FLOW DIRECTION
- 455.20 GROUNDWATER ELEVATION (FEET, MSL),  
MEASURED SEPTEMBER 26, 2016

NOTE- STABLE OHIO RIVER CONDITIONS

AERIAL SOURCE: CAGIS



Certified By:



Zimmer Station  
Clermont County, Ohio

FIGURE 1  
GROUNDWATER SURFACE MAP-  
SEPTEMBER 26, 2016  
GYPSUM RECYCLING POND (UNIT ID: 124)  
CCR SAMPLING AND ANALYSIS PLAN

SIGNATURE \_\_\_\_\_  
DATE \_\_\_\_\_

DATE	REV NO.	DWG. BY	CHKD. BY
12/44/16	0	ALW	MAW

JOB NO. 60442412 **AECOM**



J:\Project\DYNEGY\60442412 Miami Fort and Zimmer CCR 2015-2017\Data-Tech\TIZIM\ZIM\_PIEZ\gyp\_recy\_pond\_fig1\_12-16.ai



- UNIT BOUNDARY
- + DOWNGRADIENT MONITORING WELL LOCATION
- + UPGRADIENT MONITORING WELL LOCATION
- WATER TABLE CONTOUR  
(INFERRED FROM AVAILABLE MONITORING DATA)
- GROUNDWATER FLOW DIRECTION
- 455.44 GROUNDWATER ELEVATION (FEET, MSL),  
MEASURED DECEMBER 12, 2016

NOTE- SHORT-TERM FALLING RIVER STAGE DURING  
RISING LONG-TERM OHIO RIVER CONDITIONS

AERIAL SOURCE: CAGIS

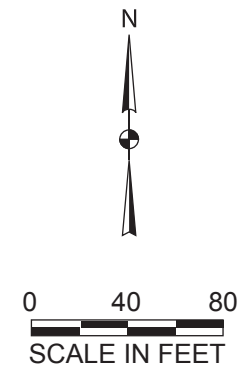

Certified By:



Zimmer Station  
Clermont County, Ohio

FIGURE 1  
GROUNDWATER SURFACE MAP-  
DECEMBER 12, 2016  
GYPSUM RECYCLING POND (UNIT ID: 124)  
CCR SAMPLING AND ANALYSIS PLAN

SIGNATURE \_\_\_\_\_  
DATE \_\_\_\_\_

DATE	REV NO.	DWG. BY	CHKD. BY
01/05/16	0	ALW	MAW

JOB NO. 60442412 **AECOM**



J:\Project\DYnegy\60442412 Miami Fort and Zimmer CCR 2015-2017\Data-Tech\T\Z\IM\ZIM PIEZ\gyp recy pond fig\_3-17.ai



- UNIT BOUNDARY
- + DOWNGRADIENT MONITORING WELL LOCATION
- + UPGRADIENT MONITORING WELL LOCATION
- WATER TABLE CONTOUR  
(INFERRED FROM AVAILABLE MONITORING DATA)
- GROUNDWATER FLOW DIRECTION
- 467.81 GROUNDWATER ELEVATION (FEET, MSL),  
MEASURED MARCH 8, 2017

NOTE- FALLING OHIO RIVER CONDITIONS FROM  
NEAR FLOOD STAGE

AERIAL SOURCE: CAGIS



0 40 80  
SCALE IN FEET

Certified By:



Zimmer Station  
Clermont County, Ohio

FIGURE 1  
GROUNDWATER SURFACE MAP-  
MARCH 8, 2017  
GYPSUM RECYCLING POND (UNIT ID: 124)  
CCR SAMPLING AND ANALYSIS PLAN

SIGNATURE \_\_\_\_\_  
DATE \_\_\_\_\_

DATE	REV NO.	DWG. BY	CHKD. BY
09/19/17	0	ALW	MAW

JOB NO. 60442412





J:\Project\DYnegy\60442412 Miami Fort and Zimmer CCR 2015-2017\Data-Tech\T\ZIMZIM PIEZ\gyp recy pond fig\_6-17.ai



- UNIT BOUNDARY
- + DOWNGRADIENT MONITORING WELL LOCATION
- + UPGRADIENT MONITORING WELL LOCATION
- WATER TABLE CONTOUR  
(INFERRED FROM AVAILABLE MONITORING DATA)
- GROUNDWATER FLOW DIRECTION
- 465.09 GROUNDWATER ELEVATION (FEET, MSL),  
MEASURED JUNE 8, 2017

NOTE- FALLING OHIO RIVER CONDITIONS

AERIAL SOURCE: CAGIS



Certified By:



Zimmer Station  
Clermont County, Ohio

**FIGURE 1**  
GROUNDWATER SURFACE MAP-  
JUNE 8, 2017  
GYPSUM RECYCLING POND (UNIT ID: 124)  
CCR SAMPLING AND ANALYSIS PLAN

SIGNATURE \_\_\_\_\_  
DATE \_\_\_\_\_

DATE	REV NO.	DWG. BY	CHKD. BY
09/19/17	0	ALW	MAW

JOB NO. 60442412 **AECOM**



J:\Project\DYnegy\60442412 Miami Fort and Zimmer CCR 2015-2017\Data-Tech\TIZIMIZIM PIEZGYPP recy pond fig\_7-17.ai



- UNIT BOUNDARY
- + DOWNGRADE MONITORING WELL LOCATION
- + UPGRADIENT MONITORING WELL LOCATION
- WATER TABLE CONTOUR  
(INFERRED FROM AVAILABLE MONITORING DATA)
- GROUNDWATER FLOW DIRECTION
- 462.21 GROUNDWATER ELEVATION (FEET, MSL),  
MEASURED JULY 13, 2017

NOTE- STABLE OHIO RIVER CONDITIONS

AERIAL SOURCE: CAGIS

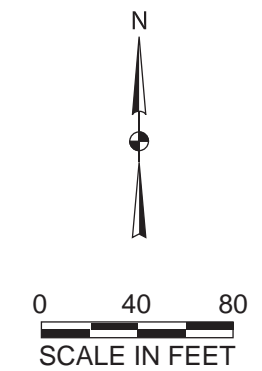

Certified By: \_\_\_\_\_

SIGNATURE \_\_\_\_\_

DATE \_\_\_\_\_

		Zimmer Station Clermont County, Ohio	
		<b>FIGURE 1</b> GROUNDWATER SURFACE MAP- JULY 13, 2017 GYPSUM RECYCLING POND (UNIT ID: 124) CCR SAMPLING AND ANALYSIS PLAN	
DATE	REV NO.	DWG. BY	CHKD. BY
09/19/17	0	ALW	MAW
JOB NO. 60442412			<b>AECOM</b>





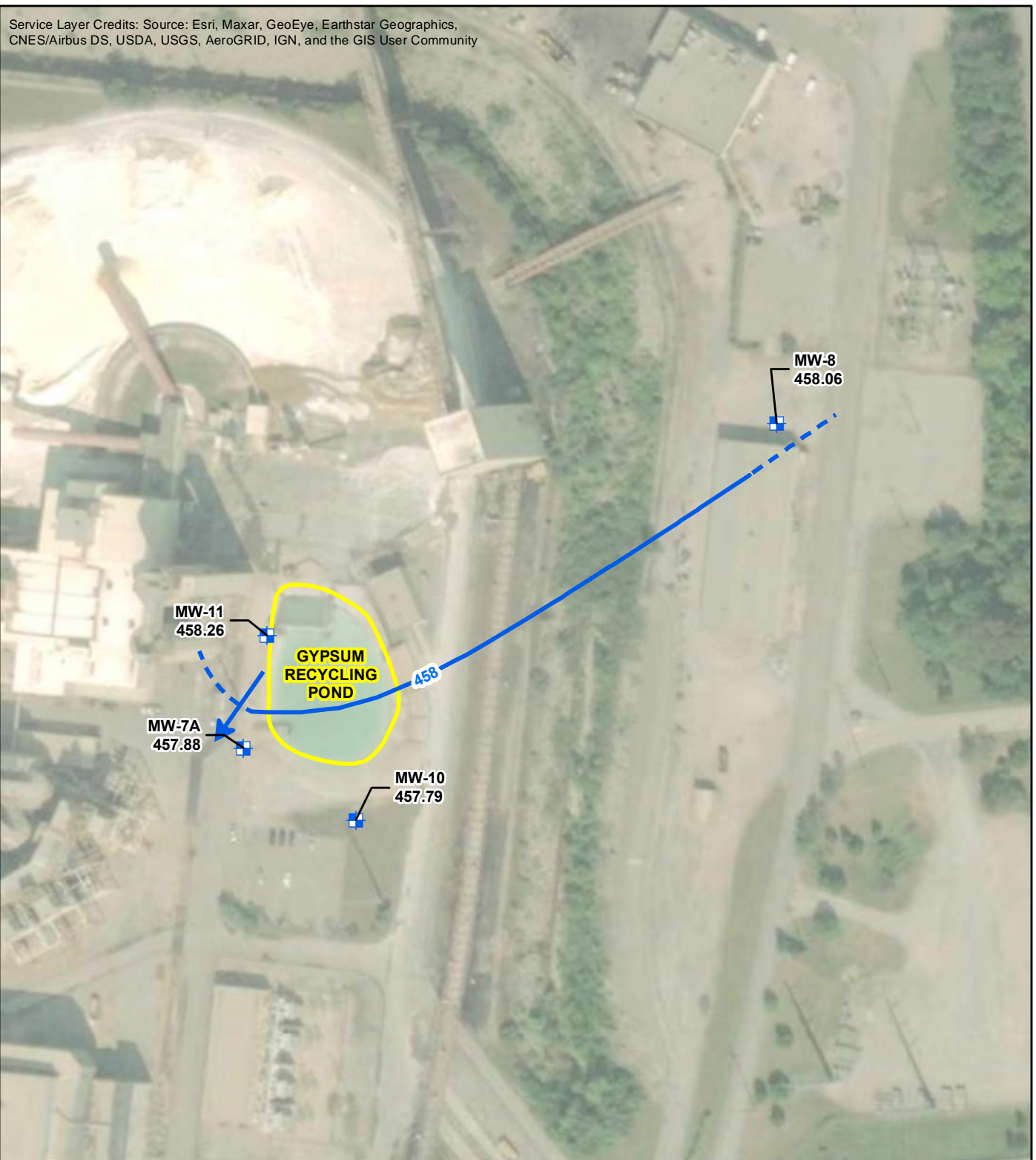

10/9/2019 2:43:54 PM

Service Layer Credits: Source: Esri, Maxar, GeoEye, Earthstar Geographics, CNES/Airbus DS, USDA, USGS, AeroGRID, IGN, and the GIS User Community

Y:\Mapping\Projects\222285\MXD\GW\_Contours\Round\_09\09\_ZimmerGRP\_GW\_Contours.mxd



-  CCR MONITORING WELL LOCATION
-  GROUNDWATER ELEVATION CONTOUR (1-FT CONTOUR INTERVAL, FT MSL)
-  INFERRED GROUNDWATER CONTOUR
-  GROUNDWATER FLOW DIRECTION
-  CCR MONITORED UNIT

ZIMMER GYPSUM RECYCLE POND (UNIT ID: 124)  
GROUNDWATER ELEVATION CONTOUR MAP  
NOVEMBER 13, 2017

CCR RULE GROUNDWATER MONITORING  
ZIMMER POWER STATION  
MOSCOW, OHIO

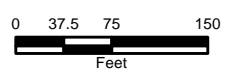





8/13/2020 3:43:30 PM

Service Layer Credits: Source: Esri, Maxar, GeoEye, Earthstar Geographics, CNES/Airbus DS, USDA, USGS, AeroGRID, IGN, and the GIS User Community

Y:\Mapping\Projects\22\2285\MXD\GW\_Contours\Round\_2018\_20\Round\_20\_ZimmerGRP\_GW\_Contours.mxd



-  CCR MONITORING WELL LOCATION
-  GROUNDWATER ELEVATION CONTOUR (0.5-FT CONTOUR INTERVAL, FT MSL)
-  INFERRED GROUNDWATER CONTOUR
-  GROUNDWATER FLOW DIRECTION
-  CCR MONITORED UNIT

ZIMMER GYPSUM RECYCLE POND (UNIT ID: 124)  
GROUNDWATER ELEVATION CONTOUR MAP  
MAY 9, 2018

CCR RULE GROUNDWATER MONITORING  
ZIMMER POWER STATION  
MOSCOW, OHIO

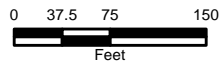







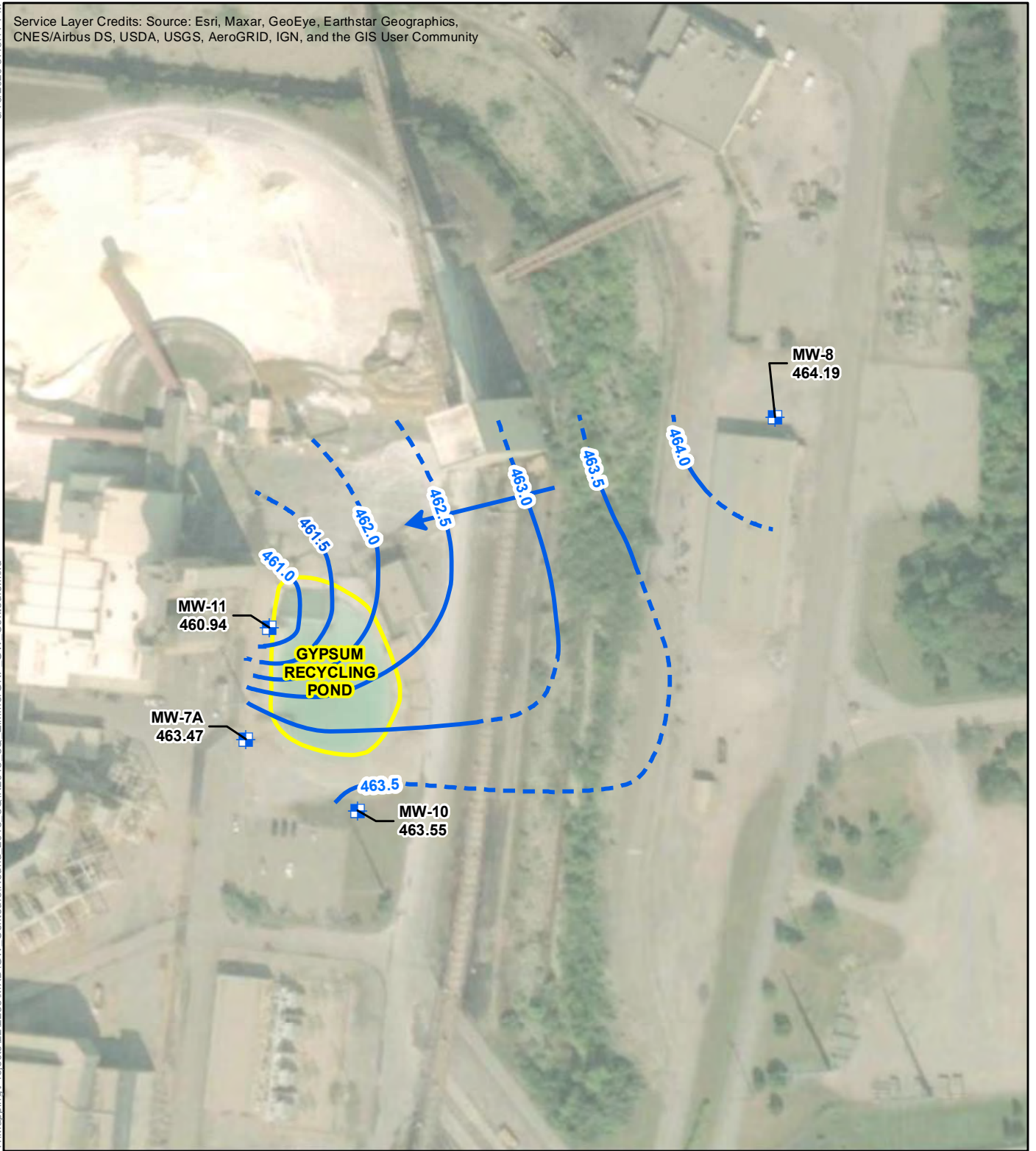

8/13/2020 3:45:17 PM

Service Layer Credits: Source: Esri, Maxar, GeoEye, Earthstar Geographics, CNES/Airbus DS, USDA, USGS, AeroGRID, IGN, and the GIS User Community

Y:\Mapping\Projects\222285\MXD\GW\_Contours\Round\_2018\_30\Round\_2018\_30\_ZimmerGRP\_GW\_Contours.mxd



-  CCR MONITORING WELL LOCATION
-  GROUNDWATER ELEVATION CONTOUR (0.5-FT CONTOUR INTERVAL, FT MSL)
-  INFERRED GROUNDWATER CONTOUR
-  GROUNDWATER FLOW DIRECTION
-  CCR MONITORED UNIT

ZIMMER GYPSUM RECYCLE POND (UNIT ID: 124)  
GROUNDWATER ELEVATION CONTOUR MAP  
MAY 9, 2018

CCR RULE GROUNDWATER MONITORING  
ZIMMER POWER STATION  
MOSCOW, OHIO

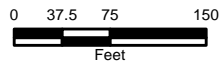







10/4/2019 3:42:37 PM

Service Layer Credits: Source: Esri, Maxar, GeoEye, Earthstar Geographics, CNES/Airbus DS, USDA, USGS, AeroGRID, IGN, and the GIS User Community

Y:\Mapping\Projects\222285\MXD\GW\_Contours\Round\_2019\_1\Q\B2019\_1Q\_ZimmerGRP\_GW\_Contours.mxd



-  CCR MONITORING WELL LOCATION
-  GROUNDWATER ELEVATION CONTOUR (0.25-FT CONTOUR INTERVAL, FT MSL)
-  INFERRED GROUNDWATER CONTOUR
-  GROUNDWATER FLOW DIRECTION
-  CCR MONITORED UNIT

ZIMMER GYPSUM RECYCLE POND (UNIT ID: 124)  
GROUNDWATER ELEVATION CONTOUR MAP  
MARCH 12, 2019

CCR RULE GROUNDWATER MONITORING  
ZIMMER POWER STATION  
MOSCOW, OHIO







10/21/2019 11:46:16 AM

Service Layer Credits: Source: Esri, Maxar, GeoEye, Earthstar Geographics, CNES/Airbus DS, USDA, USGS, AeroGRID, IGN, and the GIS User Community

Y:\Mapping\Projects\222285\MXD\GW\_Contours\Round\_2019\_30\Round\_2019\_30\_ZimmerGRP\_GW\_Contours.mxd



-  CCR MONITORING WELL LOCATION
-  GROUNDWATER ELEVATION CONTOUR (1-FT CONTOUR INTERVAL, FT MSL)
-  INFERRED GROUNDWATER CONTOUR
-  GROUNDWATER FLOW DIRECTION
-  CCR MONITORED UNIT

**ZIMMER GYPSUM RECYCLE POND (UNIT ID: 124)  
GROUNDWATER ELEVATION CONTOUR MAP  
SEPTEMBER 10, 2019**





CCR RULE GROUNDWATER MONITORING  
ZIMMER POWER STATION  
MOSCOW, OHIO

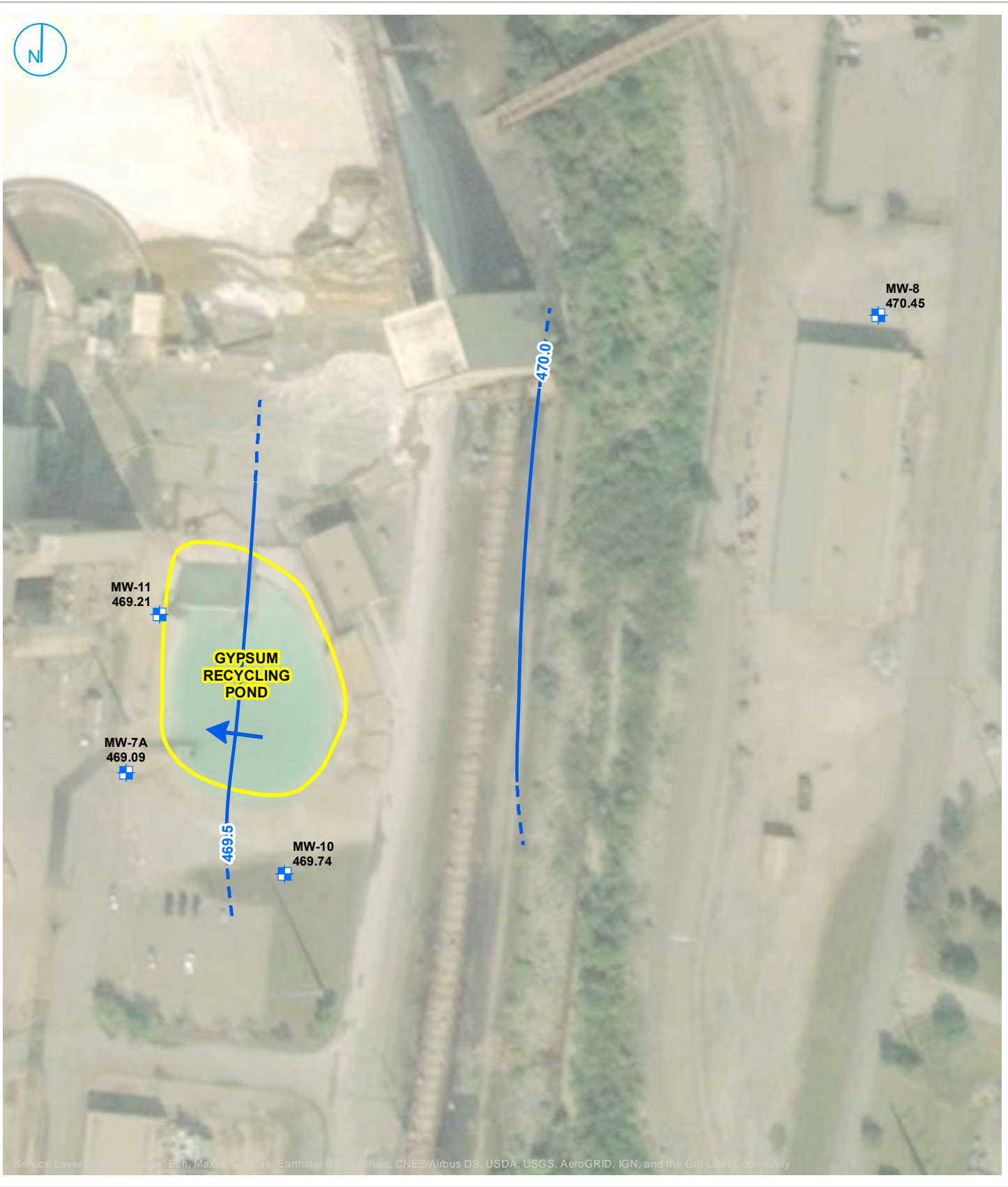





Service Layer Credits: Source: Esri, Maxar, GeoEye, Earthstar Geographics, CNES/Airbus DS, USDA, USGS, AeroGRID, IGN, and the GIS User Community

-  CCR MONITORING WELL LOCATION
-  GROUNDWATER ELEVATION CONTOUR (0.5-FT CONTOUR INTERVAL, FT MSL)
-  INFERRED GROUNDWATER ELEVATION CONTOUR
-  GROUNDWATER FLOW DIRECTION
-  CCR MONITORED UNIT

**GROUNDWATER ELEVATION  
CONTOUR MAP  
APRIL 9, 2020**



**ZIMMER GYPSUM RECYCLE POND (UNIT ID: 124)**  
ZIMMER POWER STATION  
MOSCOW, OHIO

RAMBOLL US CORPORATION  
A RAMBOLL COMPANY





J:\Project\IDynegy\60442412 Miami Fort and Zimmer CCR 2015-2017\Data-Tech\TIV\MZ\IM PIEZibasin d fig\_1\_12-15.ai

← Ohio River  
Rising River Conditions to  
near flood stage



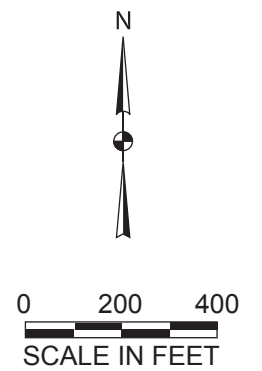

- UNIT BOUNDARY
- + DOWNGRAIDENT MONITORING WELL LOCATION
- + UPGRADIENT MONITORING WELL LOCATION
- - - WATER TABLE CONTOUR  
(INFERRED FROM AVAILABLE MONITORING DATA)
- GROUNDWATER FLOW DIRECTION
- 463.65 GROUNDWATER ELEVATION (FEET, MSL),  
MEASURED DECEMBER 29, 2015

AERIAL SOURCE: CAGIS



Certified By: \_\_\_\_\_  
SIGNATURE \_\_\_\_\_  
DATE \_\_\_\_\_

 Zimmer Station Clermont County, Ohio		FIGURE 1 GROUNDWATER SURFACE MAP- DECEMBER 29, 2015 D BASIN (UNIT ID: 121) CCR SAMPLING AND ANALYSIS PLAN			
				DATE	REV NO.
		08/04/16	0	ALW	MAW
JOB NO. 60442412					



J:\Project\IDynegy\60442412 Miami Fort and Zimmer CCR 2015-2017\Data-Tech\T\ZIMZIM\_PIEZbasin d fig1\_3-16.ai

Ohio River  
 Rapid Rising River Conditions  
 following rapid decending conditions from  
 near flood stage



- UNIT BOUNDARY
- + DOWNGRAIDENT MONITORING WELL LOCATION
- + UPGRADIENT MONITORING WELL LOCATION
- WATER TABLE CONTOUR  
(INFERRED FROM AVAILABLE MONITORING DATA)
- GROUNDWATER FLOW DIRECTION
- 469.30 GROUNDWATER ELEVATION (FEET, MSL),  
MEASURED MARCH 16, 2016

AERIAL SOURCE: CAGIS



0 200 400  
 SCALE IN FEET

Certified By:



Zimmer Station  
 Clermont County, Ohio

FIGURE 1  
 GROUNDWATER SURFACE MAP-  
 MARCH 16, 2016  
 D BASIN (UNIT ID: 121)  
 CCR SAMPLING AND ANALYSIS PLAN

SIGNATURE \_\_\_\_\_  
 DATE \_\_\_\_\_

DATE	REV NO.	DWG. BY	CHKD. BY
08/04/16	0	ALW	MAW

JOB NO. 60442412





J:\Project\IDynegy\60442412 Miami Fort and Zimmer CCR 2015-2017\Data-Tech\T\ZIMZIM\_PIEZbasin d fig\_6-16.ai



Ohio River  
Stable River Conditions

- UNIT BOUNDARY
- + DOWNGRADIENT MONITORING WELL LOCATION
- + UPGRADIENT MONITORING WELL LOCATION
- WATER TABLE CONTOUR  
(INFERRED FROM AVAILABLE MONITORING DATA)
- GROUNDWATER FLOW DIRECTION
- 461.87 GROUNDWATER ELEVATION (FEET, MSL),  
MEASURED JUNE 15, 2016

AERIAL SOURCE: CAGIS



0 200 400  
SCALE IN FEET

Certified By:



Zimmer Station  
Clermont County, Ohio

FIGURE 1  
GROUNDWATER SURFACE MAP-  
JUNE 15, 2016  
D BASIN (UNIT ID: 121)  
CCR SAMPLING AND ANALYSIS PLAN

SIGNATURE \_\_\_\_\_  
DATE \_\_\_\_\_

DATE	REV NO.	DWG. BY	CHKD. BY
08/04/16	0	ALW	MAW

JOB NO. 60442412





J:\Project\IDynegy\60442412 Miami Fort and Zimmer CCR 2015-2017\Data-Tech\T\ZIMZIM\_PIEZbasin d fig\_9-16.ai



- UNIT BOUNDARY
- + DOWNGRADIENT MONITORING WELL LOCATION
- + UPGRADIENT MONITORING WELL LOCATION
- WATER TABLE CONTOUR  
(INFERRED FROM AVAILABLE MONITORING DATA)
- GROUNDWATER FLOW DIRECTION
- 456.53 GROUNDWATER ELEVATION (FEET, MSL),  
MEASURED SEPTEMBER 26, 2016

AERIAL SOURCE: CAGIS



0 200 400  
SCALE IN FEET

Certified By:



Zimmer Station  
Clermont County, Ohio

FIGURE 1  
GROUNDWATER SURFACE MAP-  
SEPTEMBER 26, 2016  
D BASIN (UNIT ID: 121)  
CCR SAMPLING AND ANALYSIS PLAN

SIGNATURE \_\_\_\_\_  
DATE \_\_\_\_\_

DATE	REV NO.	DWG. BY	CHKD. BY
12/14/16	0	ALW	MAW

JOB NO. 60442412









J:\Project\ID\dynegy\60442412\_Miami\_Fort\_and\_Zimmer\_CCR\_2015-2017\Data-Tech\TIV\ZIM\ZIM\_PIEZibasin\_d\_fig1\_12-16.ai

Ohio River  
Short-term Falling River Stage during  
Long-term Rising River Conditions



-  UNIT BOUNDARY
-  DOWNGRAIDENT MONITORING WELL LOCATION
-  UPGRADIENT MONITORING WELL LOCATION
-  WATER TABLE CONTOUR  
(INFERRED FROM AVAILABLE MONITORING DATA)
-  GROUNDWATER FLOW DIRECTION
- 456.77 GROUNDWATER ELEVATION (FEET, MSL),  
MEASURED DECEMBER 12, 2016

AERIAL SOURCE: CAGIS



0 200 400  
SCALE IN FEET

Certified By:



Zimmer Station  
Clermont County, Ohio

FIGURE 1  
GROUNDWATER SURFACE MAP-  
DECEMBER 12, 2016  
D BASIN (UNIT ID: 121)  
CCR SAMPLING AND ANALYSIS PLAN

SIGNATURE \_\_\_\_\_  
DATE \_\_\_\_\_

DATE	REV NO.	DWG. BY	CHKD. BY
01/05/16	0	ALW	MAW

JOB NO. 60442412 



J:\Project\IDynegy\60442412 Miami Fort and Zimmer CCR 2015-2017\Data-Tech\TIZIMZIM PIEZobasin d fig1\_3-17.ai

Ohio River  
Falling river conditions from  
near flood stage



- UNIT BOUNDARY
- + DOWNGRAIDENT MONITORING WELL LOCATION
- + UPGRADIENT MONITORING WELL LOCATION
- WATER TABLE CONTOUR  
(INFERRED FROM AVAILABLE MONITORING DATA)
- GROUNDWATER FLOW DIRECTION
- 468.36 GROUNDWATER ELEVATION (FEET, MSL),  
MEASURED MARCH 8, 2017

AERIAL SOURCE: CAGIS

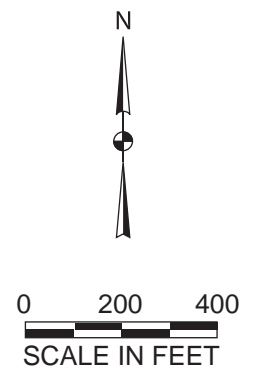

Certified By:

**DYNEGY** Zimmer Station  
Clermont County, Ohio

**FIGURE 1**  
GROUNDWATER SURFACE MAP-  
MARCH 8, 2017  
D BASIN (UNIT ID: 121)  
CCR SAMPLING AND ANALYSIS PLAN

DATE	REV NO.	DWG. BY	CHKD. BY
09/08/17	0	ALW	MAW

SIGNATURE \_\_\_\_\_  
DATE \_\_\_\_\_

JOB NO. 60442412 **AECOM**



J:\Project\IDynegy\60442412 Miami Fort and Zimmer CCR 2015-2017\Data-Tech\TZIMZIM PIEZobasin d fig1\_6-17.ai



- UNIT BOUNDARY
- + DOWNGRAIENT MONITORING WELL LOCATION
- + UPGRADIENT MONITORING WELL LOCATION
- WATER TABLE CONTOUR  
(INFERRED FROM AVAILABLE MONITORING DATA)
- GROUNDWATER FLOW DIRECTION
- 466.54 GROUNDWATER ELEVATION (FEET, MSL),  
MEASURED JUNE 8, 2017

AERIAL SOURCE: CAGIS

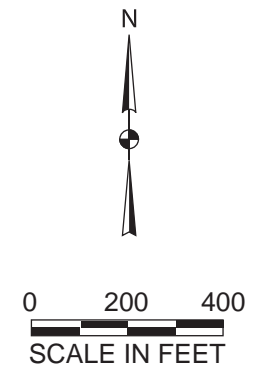

Certified By:



Zimmer Station  
Clermont County, Ohio

**FIGURE 1**  
**GROUNDWATER SURFACE MAP-**  
**JUNE 8, 2017**  
**D BASIN (UNIT ID: 121)**  
**CCR SAMPLING AND ANALYSIS PLAN**

SIGNATURE \_\_\_\_\_  
DATE \_\_\_\_\_

DATE	REV NO.	DWG. BY	CHKD. BY
09/08/17	0	ALW	MAW

JOB NO. 60442412





J:\Project\IDynegy\60442412 Miami Fort and Zimmer CCR 2015-2017\Data-Tech\TIZ\TIZ\MZIM\_PIEZobasin d fig1\_7-17.ai



- UNIT BOUNDARY
- + DOWNGRAIENT MONITORING WELL LOCATION
- + UPGRADIENT MONITORING WELL LOCATION
- WATER TABLE CONTOUR  
(INFERRED FROM AVAILABLE MONITORING DATA)
- GROUNDWATER FLOW DIRECTION
- 463.14 GROUNDWATER ELEVATION (FEET, MSL),  
MEASURED JULY 13, 2017

AERIAL SOURCE: CAGIS



0 200 400  
SCALE IN FEET

Certified By:



Zimmer Station  
Clermont County, Ohio

FIGURE 1  
GROUNDWATER SURFACE MAP-  
JULY 13, 2017  
D BASIN (UNIT ID: 121)  
CCR SAMPLING AND ANALYSIS PLAN

SIGNATURE \_\_\_\_\_  
DATE \_\_\_\_\_

DATE	REV NO.	DWG. BY	CHKD. BY
09/08/17	0	ALW	MAW





JOB NO. 60442412





Service Layer Credits: Source: Esri, Maxar, GeoEye, Earthstar Geographics, CNES/Airbus DS, USDA, USGS, AeroGRID, IGN, and the GIS User Community



-  CCR MONITORING WELL LOCATION
-  GROUNDWATER ELEVATION CONTOUR (1-FT CONTOUR INTERVAL, FT MSL)
-  INFERRED GROUNDWATER ELEVATION CONTOUR
-  GROUNDWATER FLOW DIRECTION
-  CCR MONITORED UNIT

ZIMMER D BASIN (UNIT ID: 121) AND  
 ZIMMER COAL PILE RUNOFF POND (UNIT ID: 125)  
 GROUNDWATER ELEVATION CONTOUR MAP  
 NOVEMBER 13, 2017

CCR RULE GROUNDWATER MONITORING  
 ZIMMER POWER STATION  
 MOSCOW, OHIO

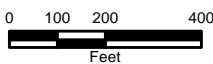



Service Layer Credits: Source: Esri, Maxar, GeoEye, Earthstar Geographics, CNES/Airbus DS, USDA, USGS, AeroGRID, IGN, and the GIS User Community



- CCR MONITORING WELL LOCATION
- GROUNDWATER ELEVATION CONTOUR (1-FT CONTOUR INTERVAL, FT MSL)
- INFERRED GROUNDWATER ELEVATION CONTOUR
- GROUNDWATER FLOW DIRECTION
- CCR MONITORED UNIT

ZIMMER D BASIN (UNIT ID: 121) AND  
 ZIMMER COAL PILE RUNOFF POND (UNIT ID: 125)  
 GROUNDWATER ELEVATION CONTOUR MAP  
 MAY 7-9, 2018

CCR RULE GROUNDWATER MONITORING  
 ZIMMER POWER STATION  
 MOSCOW, OHIO

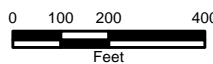

Service Layer Credits: Source: Esri, Maxar, GeoEye, Earthstar Geographics, CNES/Airbus DS, USDA, USGS, AeroGRID, IGN, and the GIS User Community



- CCR MONITORING WELL LOCATION
- GROUNDWATER ELEVATION CONTOUR (1-FT CONTOUR INTERVAL, FT MSL)
- INFERRED GROUNDWATER ELEVATION CONTOUR
- GROUNDWATER FLOW DIRECTION
- CCR MONITORED UNIT

ZIMMER D BASIN (UNIT ID: 121) AND  
ZIMMER COAL PILE RUNOFF POND (UNIT ID: 125)  
GROUNDWATER ELEVATION CONTOUR MAP  
SEPTEMBER 18, 2018

CCR RULE GROUNDWATER MONITORING  
ZIMMER POWER STATION  
MOSCOW, OHIO

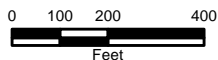







Service Layer Credits: Source: Esri, Maxar, GeoEye, Earthstar Geographics, CNES/Airbus DS, USDA, USGS, AeroGRID, IGN, and the GIS User Community



NOTE:  
GAUGING DATA FROM USGS 03255000  
OHIO RIVER AT CINCINNATI, OH

-  CCR MONITORING WELL LOCATION
-  GROUNDWATER ELEVATION CONTOUR (1-FT CONTOUR INTERVAL, FT MSL)
-  INFERRED GROUNDWATER ELEVATION CONTOUR
-  GROUNDWATER FLOW DIRECTION
-  CCR MONITORED UNIT

ZIMMER D BASIN (UNIT ID: 121) AND  
ZIMMER COAL PILE RUNOFF POND (UNIT ID: 125)  
GROUNDWATER ELEVATION CONTOUR MAP  
MARCH 13, 2019

CCR RULE GROUNDWATER MONITORING  
ZIMMER POWER STATION  
MOSCOW, OHIO



Service Layer Credits: Source: Esri, Maxar, GeoEye, Earthstar Geographics, CNES/Airbus DS, USDA, USGS, AeroGRID, IGN, and the GIS User Community



NOTE:  
GAUGING DATA FROM USGS 03255000  
OHIO RIVER AT CINCINNATI, OH

- CCR MONITORING WELL LOCATION
- GROUNDWATER ELEVATION CONTOUR (1-FT CONTOUR INTERVAL, FT MSL)
- INFERRED GROUNDWATER ELEVATION CONTOUR
- GROUNDWATER FLOW DIRECTION
- CCR MONITORED UNIT

ZIMMER D BASIN (UNIT ID: 121) AND  
ZIMMER COAL PILE RUNOFF POND (UNIT ID: 125)  
GROUNDWATER ELEVATION CONTOUR MAP  
SEPTEMBER 10, 2019

CCR RULE GROUNDWATER MONITORING  
ZIMMER POWER STATION  
MOSCOW, OHIO

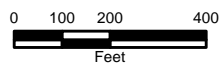

O'BRIEN & GERE ENGINEERS, INC.



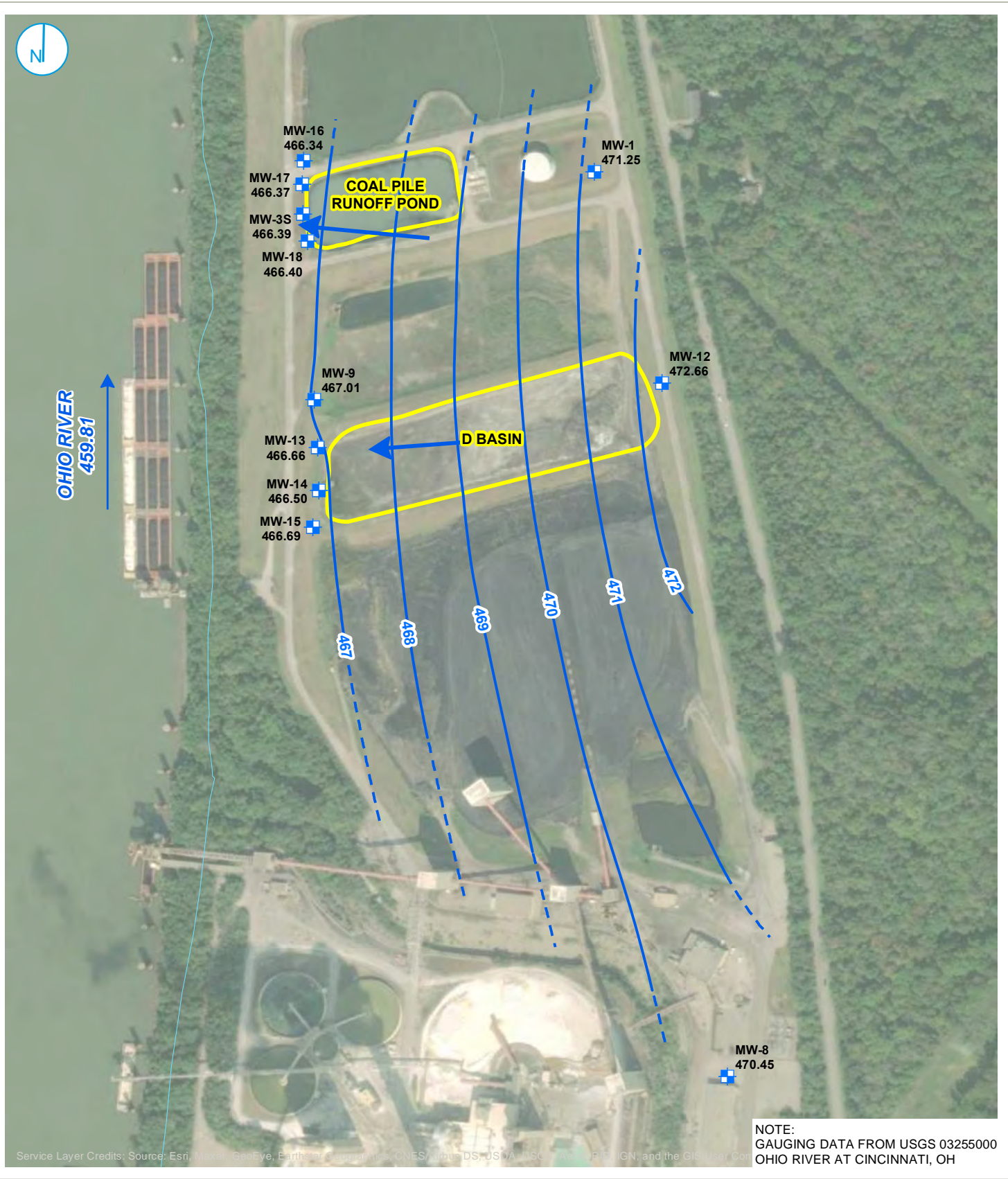

NOTE:  
GAUGING DATA FROM USGS 03255000  
OHIO RIVER AT CINCINNATI, OH

- CCR MONITORING WELL LOCATION
- GROUNDWATER ELEVATION CONTOUR (1-FT CONTOUR INTERVAL, FT MSL)
- INFERRED GROUNDWATER ELEVATION CONTOUR
- GROUNDWATER FLOW DIRECTION
- SURFACE WATER FEATURE
- CCR MONITORED UNIT



### GROUNDWATER ELEVATION CONTOUR MAP APRIL 9, 2020

ZIMMER D BASIN (UNIT ID: 121) AND  
ZIMMER COAL PILE RUNOFF POND (UNIT ID: 125)  
ZIMMER POWER STATION  
MOSCOW, OHIO

RAMBOLL US CORPORATION  
A RAMBOLL COMPANY



**APPENDIX C4 – TABLES SUMMARIZING CONSTITUENT CONCENTRATIONS AT  
EACH MONITORING WELL**



Analytical Results - Appendix III  
Zimmer Coal Pile Runoff Pond

Sample Location	Date Sampled	Boron, total (mg/L)	Calcium, total (mg/L)	Chloride, total (mg/L)	Fluoride, total (mg/L)	pH (s.u.)	Sulfate, total (mg/L)	Total Dissolved Solids (mg/L)
<b>Background Wells</b>								
MW-1	12/30/2015	0.0720	155	48.5	0.200	7.2	90.1	544
MW-1	3/16/2016	0.0233	206	59.1	0.146	7.1	85.2	583
MW-1	6/16/2016	0.0389	154	59.6	<1	7.0	95.3	648
MW-1	8/31/2016	0.0431	168	73.4	<1	6.4	113	612
MW-1	9/26/2016	0.0349	160	64.9	<1	7.1	93.1	621
MW-1	10/12/2016	0.0634	156	79.2	<1	7.2	112	571
MW-1	11/16/2016	0.0304	162	57.7	<1	6.4	90.6	596
MW-1	12/13/2016	0.0322	165	52.4	<1	7.0	93.3	561
MW-1	3/9/2017	<0.08	150	58.2	<1	8.3	85.9	589
MW-1	6/8/2017	<0.08	171	65.5	<1	7.1	87.0	582
MW-1	7/13/2017	<0.08	144	61.3	<1	7.0	79.0	608
MW-1	11/13/2017	<0.08	150	53.1	<1	6.9	89.1	571
MW-1	5/9/2018	<1	157	71.0	<1	7.0	88.9	631
MW-1	9/27/2018	<0.08	163	62.7	<1	6.9	113	578
MW-1	3/14/2019	<0.08	152	78.7	<1	7.0	90.2	617
MW-1	9/11/2019	<0.08	167	63.1	<1	7.0	90.6	637
MW-1	4/9/2020	0.123	170	80.5	<0.15	6.7	92.3	592
<b>Downgradient Wells</b>								
MW-3S	8/31/2016	0.109	194	<60	<1	6.9	371	860
MW-3S	9/26/2016	0.209	188	54.7	<1	6.9	338	830
MW-3S	10/12/2016	0.0983	168	66.3	<1	6.9	328	779
MW-3S	11/16/2016	0.0710	169	44.0	<1	7.5	268	706
MW-3S	12/12/2016	0.0567	131	36.4	<1	6.7	179	559
MW-3S	3/9/2017	<0.08	139	37.2	<1	8.3	242	665
MW-3S	6/8/2017	<0.08	208	69.5	<1	7.0	384	892
MW-3S	7/13/2017	0.0984	201	<60	<1	7.2	399	934
MW-3S	11/13/2017	<0.08	127	33.8	<1	6.5	176	560
MW-3S	5/9/2018	<1	115	32.1	<1	6.7	151	568
MW-3S	9/19/2018	0.188	162	41.3	<1	6.7	251	720
MW-3S	3/15/2019	0.143	160	37.3	<1	6.9	199	683
MW-3S	9/11/2019	1.91	228	39.2	<1	7.6	532	1090
MW-3S	4/10/2020	1.03	221	43.0	<0.15	7.0	447	949
MW-16	8/31/2016	0.0506	143	41.8	<1	6.4	198	642
MW-16	9/26/2016	0.102	163	42.2	<1	6.8	173	639
MW-16	10/12/2016	0.0689	149	51.6	<1	7.2	172	609
MW-16	11/16/2016	0.0446	151	38.8	<1	6.4	168	628
MW-16	12/12/2016	0.0527	151	37.8	<1	7.0	175	612
MW-16	3/9/2017	<0.08	106	28.0	<1	8.5	121	484
MW-16	6/8/2017	<0.08	132	31.8	<1	7.1	155	541
MW-16	7/13/2017	<0.08	135	36.1	<1	7.2	161	605
MW-16	11/13/2017	<0.08	139	38.8	<1	7.0	169	592
MW-16	5/9/2018	<1	128	32.3	<1	7.0	145	571
MW-16	9/19/2018	<0.08	153	38.5	<1	6.9	175	640
MW-16	3/15/2019	<0.08	153	39.4	<1	7.0	160	621
MW-16	9/12/2019	0.130	156	45.5	<1	6.8	187	686
MW-16	4/10/2020	0.0621	162	47.6	0.151	6.9	197	687

Analytical Results - Appendix III  
Zimmer Coal Pile Runoff Pond

Sample Location	Date Sampled	Boron, total (mg/L)	Calcium, total (mg/L)	Chloride, total (mg/L)	Fluoride, total (mg/L)	pH (s.u.)	Sulfate, total (mg/L)	Total Dissolved Solids (mg/L)
MW-17	8/31/2016	0.0584	128	36.3	<1	7.1	190	646
MW-17	9/26/2016	0.0757	147	32.0	<1	7.1	181	622
MW-17	10/12/2016	0.0478	126	39.5	<1	7.4	174	596
MW-17	11/16/2016	0.0447	142	38.7	<1	6.4	167	615
MW-17	12/12/2016	0.0569	145	37.6	<1	7.2	184	608
MW-17	3/9/2017	<0.08	112	<30	<1	8.4	159	528
MW-17	6/8/2017	<0.08	135	31.7	<1	7.1	182	602
MW-17	7/13/2017	<0.08	137	70.2	<1	7.1	390	626
MW-17	11/13/2017	<0.08	145	39.4	<1	7.1	180	627
MW-17	5/9/2018	<1	125	34.9	<1	7.1	167	603
MW-17	9/19/2018	<0.08	152	35.8	<1	6.9	187	659
MW-17	3/15/2019	<0.08	144	38.3	<1	7.1	174	620
MW-17	9/12/2019	0.0889	177	47.8	<1	7.0	280	776
MW-17	4/10/2020	0.0608	178	51.1	0.162	7.0	283	767
MW-18	8/31/2016	4.54	312	67.4	<1	7.0	973	1640
MW-18	9/26/2016	4.11	321	70.6	<1	7.2	874	1660
MW-18	10/12/2016	3.78	287	66.2	<1	7.3	924	1570
MW-18	11/16/2016	4.46	307	<60	<1	7.7	1130	1570
MW-18	12/12/2016	5.14	336	63.3	<1	7.1	918	1570
MW-18	3/9/2017	4.43	287	77.9	<1	8.3	844	1510
MW-18	6/8/2017	3.27	311	59.1	<1	7.0	883	1440
MW-18	7/13/2017	4.85	318	70.8	<1	7.2	1170	1760
MW-18	11/13/2017	3.72	322	54.0	<1	6.9	931	1520
MW-18	5/9/2018	2.62	249	56.5	<1	7.0	748	1450
MW-18	9/19/2018	4.32	306	52.1	<1	6.9	795	1600
MW-18	3/15/2019	2.77	262	49.0	<1	7.0	711	1370
MW-18	9/12/2019	3.00	226	30.8	<1	7.1	612	1210
MW-18	4/10/2020	3.56	272	43.2	0.161	7.0	771	1300

Notes:

1. Abbreviations: mg/L - milligrams per liter; s.u. - standard units.



Analytical Results - Appendix IV  
Zimmer Coal Pile Runoff Pond

Sample Location	Date Sampled	Antimony, total (mg/L)	Arsenic, total (mg/L)	Barium, total (mg/L)	Beryllium, total (mg/L)	Cadmium, total (mg/L)	Chromium, total (mg/L)	Cobalt, total (mg/L)	Fluoride, total (mg/L)	Lead, total (mg/L)	Lithium, total (mg/L)	Mercury, total (mg/L)	Molybdenum, total (mg/L)	Radium-226 + Radium 228, tot (pCi/L)	Selenium, total (mg/L)	Thallium, total (mg/L)
<b>Background Wells</b>																
MW-1	12/30/2015	<0.0005	0.00142	0.0655	<0.001	<0.0004	0.00191	<0.0005	0.200	<0.0002	<0.008	<0.0001	<0.0005	0.348	<0.0006	<0.0005
MW-1	3/16/2016	<0.00418	<0.00295	0.0863	<0.000875	<0.00025	<0.0025	<0.000543	0.146	<0.000433	0.0101	<0.0001	<0.0025	0.453	<0.00398	<0.00138
MW-1	6/16/2016	<0.002	<0.001	0.0601	<0.001	<0.001	<0.002	<0.0005	<1	<0.001	<0.00959	<0.0002	<0.005	0.603	<0.005	<0.001
MW-1	8/31/2016	<0.002	<0.001	0.0660	<0.001	<0.001	<0.002	<0.0005	<1	<0.001	0.0102	<0.0002	<0.005	0.0844	<0.005	<0.001
MW-1	9/26/2016	<0.002	<0.001	0.0627	<0.001	<0.001	<0.002	<0.0005	<1	<0.001	<0.00959	<0.0002	<0.005	0.168	<0.005	<0.001
MW-1	10/12/2016	<0.002	<0.001	0.0639	<0.001	<0.001	<0.002	<0.0005	<1	0.00268	<0.01	<0.0002	<0.005	0.489	<0.005	<0.001
MW-1	11/16/2016	<0.002	<0.001	0.0670	<0.001	<0.001	<0.002	<0.0005	<1	<0.001	0.0097	<0.0002	<0.005	0.339	<0.005	<0.001
MW-1	12/13/2016	<0.002	<0.001	0.0629	<0.001	<0.001	<0.002	<0.0005	<1	<0.001	<0.00959	<0.0002	<0.005	0.422	<0.005	<0.001
MW-1	3/9/2017	<0.002	<0.001	0.0587	<0.001	<0.001	<0.002	<0.0005	<1	<0.001	0.0107	<0.0002	<0.005	0.426	<0.005	<0.001
MW-1	6/8/2017	<0.002	<0.001	0.0643	<0.001	<0.001	<0.002	<0.0005	<1	<0.001	0.0116	<0.0002	<0.005	0.349	<0.005	<0.001
MW-1	7/13/2017	<0.002	<0.001	0.0566	<0.001	<0.001	<0.002	<0.0005	<1	<0.001	<0.00959	<0.0002	<0.005	0.144	<0.005	<0.001
MW-1	11/13/2017	NA	NA	NA	NA	NA	NA	NA	<1	NA	NA	NA	NA	NA	NA	NA
MW-1	5/9/2018	<0.003	<0.005	<0.2	<0.004	<0.005	<0.005	<0.005	<1	<0.005	<0.04	<0.0002	<0.01	0.370	<0.01	<0.002
MW-1	9/27/2018	NA	NA	NA	NA	NA	NA	NA	<1	NA	NA	NA	NA	0.231	NA	NA
MW-1	3/14/2019	<0.002	<0.001	0.0665	<0.001	<0.001	0.0023	<0.0005	<1	<0.001	0.00665	<0.0002	<0.005	0.171	<0.005	<0.001
MW-1	9/11/2019	NA	<0.001	0.0770	<0.001	NA	<0.002	<0.0005	<1	<0.001	0.0109	NA	<0.005	0.110	<0.005	NA
MW-1	4/9/2020	<0.004	<0.002	0.0725	<0.002	<0.001	<0.002	<0.002	<0.15	<0.005	0.00964	<0.0002	<0.005	0.0302	<0.002	<0.002
<b>Downgradient Wells</b>																
MW-3S	8/31/2016	<0.002	<0.001	0.0519	<0.001	<0.001	<0.002	<0.0005	<1	<0.001	<0.00959	<0.0002	<0.005	0.138	<0.005	<0.001
MW-3S	9/26/2016	<0.002	<0.001	0.0515	<0.001	<0.001	<0.002	<0.0005	<1	<0.001	<0.00959	<0.0002	<0.005	0.364	0.00588	<0.001
MW-3S	10/12/2016	<0.002	<0.001	0.0508	<0.001	<0.001	<0.002	<0.0005	<1	0.00182	<0.00959	<0.0002	<0.005	0.249	<0.005	<0.001
MW-3S	11/16/2016	<0.002	0.0019	0.0491	<0.001	<0.001	<0.002	0.00254	<1	0.00134	<0.00959	<0.0002	<0.005	0.520	0.00557	<0.001
MW-3S	12/12/2016	<0.002	<0.001	0.0393	<0.001	<0.001	<0.002	<0.0005	<1	<0.001	<0.00959	<0.0002	<0.005	0.0391	0.00529	<0.001
MW-3S	3/9/2017	<0.002	<0.001	0.0383	<0.001	<0.001	<0.002	<0.0005	<1	<0.001	<0.00959	<0.0002	<0.005	0.329	<0.005	<0.001
MW-3S	6/8/2017	<0.002	<0.001	0.0507	<0.001	<0.001	<0.002	<0.0005	<1	<0.001	<0.00959	<0.0002	<0.005	0.315	<0.005	<0.001
MW-3S	7/13/2017	<0.002	<0.001	0.0513	<0.001	<0.001	<0.002	<0.0005	<1	<0.001	<0.00959	<0.0002	<0.005	0.441	<0.005	<0.001
MW-3S	11/13/2017	NA	NA	NA	NA	NA	NA	NA	<1	NA	NA	NA	NA	NA	NA	NA
MW-3S	5/9/2018	<0.003	<0.005	<0.2	<0.004	<0.005	<0.005	<0.005	<1	<0.005	<0.04	<0.0002	<0.01	0.346	<0.01	<0.002
MW-3S	9/19/2018	NA	NA	NA	NA	NA	NA	NA	<1	NA	NA	NA	NA	0.491	NA	NA
MW-3S	3/15/2019	<0.002	<0.001	0.0517	<0.001	<0.001	<0.002	<0.0005	<1	<0.001	<0.005	<0.0002	<0.005	0.262	<0.005	<0.001
MW-3S	9/11/2019	NA	<0.001	0.0715	NA	<0.001	0.00275	<0.0005	<1	<0.001	0.0118	NA	<0.005	0.338	0.0111	NA
MW-3S	4/10/2020	<0.004	<0.002	0.0576	<0.002	<0.001	<0.002	<0.002	<0.15	<0.005	0.00548	<0.0002	<0.005	0.888	0.00390	<0.002
MW-16	8/31/2016	<0.002	<0.001	0.0371	<0.001	<0.001	<0.002	0.00402	<1	<0.001	<0.00959	<0.0002	0.00679	0.371	<0.005	<0.001
MW-16	9/26/2016	<0.002	<0.001	0.0414	<0.001	<0.001	<0.002	0.00416	<1	<0.001	<0.00959	<0.0002	0.00517	0.402	<0.005	<0.001
MW-16	10/12/2016	<0.002	0.00124	0.0432	<0.001	<0.001	<0.002	0.00417	<1	0.00383	<0.00959	<0.0002	0.00508	0.311	<0.005	<0.001
MW-16	11/16/2016	<0.002	<0.001	0.0466	<0.001	<0.001	<0.002	0.00322	<1	<0.001	<0.00959	<0.0002	0.00572	0.489	<0.005	<0.001
MW-16	12/12/2016	<0.002	<0.001	0.0453	<0.001	<0.001	<0.002	0.00461	<1	<0.001	<0.00959	<0.0002	0.00674	0.664	<0.005	<0.001
MW-16	3/9/2017	<0.002	<0.001	0.0314	<0.001	<0.001	<0.002	0.00204	<1	<0.001	<0.00959	<0.0002	<0.005	0.317	<0.005	<0.001
MW-16	6/8/2017	<0.002	<0.001	0.0348	<0.001	<0.001	<0.002	0.00246	<1	<0.001	<0.00959	<0.0002	<0.005	0.439	<0.005	<0.001
MW-16	7/13/2017	<0.002	<0.001	0.0344	<0.001	<0.001	<0.002	0.00252	<1	<0.001	<0.00959	<0.0002	<0.005	0.566	<0.005	<0.001
MW-16	11/13/2017	NA	NA	NA	NA	NA	NA	NA	<1	NA	NA	NA	NA	NA	NA	NA
MW-16	5/9/2018	<0.003	<0.005	<0.2	<0.004	<0.005	<0.005	<0.005	<1	<0.005	<0.04	<0.0002	<0.01	0.240	<0.01	<0.002
MW-16	9/19/2018	NA	NA	NA	NA	NA	NA	NA	<1	NA	NA	NA	NA	0.554	NA	NA
MW-16	3/15/2019	<0.002	<0.001	0.114	<0.001	<0.001	<0.002	0.00203	<1	<0.001	0.00677	<0.0002	<0.005	0.233	<0.005	<0.001
MW-16	9/12/2019	NA	<0.001	0.0538	NA	<0.001	0.00218	0.00201	<1	<0.001	0.0111	NA	<0.005	0.969	<0.005	NA
MW-16	4/10/2020	<0.004	<0.002	0.0474	<0.002	<0.001	<0.002	0.00208	0.151	<0.005	0.00522	<0.0002	<0.005	1.85	<0.002	<0.002

Analytical Results - Appendix IV  
Zimmer Coal Pile Runoff Pond

Sample Location	Date Sampled	Antimony, total (mg/L)	Arsenic, total (mg/L)	Barium, total (mg/L)	Beryllium, total (mg/L)	Cadmium, total (mg/L)	Chromium, total (mg/L)	Cobalt, total (mg/L)	Fluoride, total (mg/L)	Lead, total (mg/L)	Lithium, total (mg/L)	Mercury, total (mg/L)	Molybdenum, total (mg/L)	Radium-226 + Radium 228, tot (pCi/L)	Selenium, total (mg/L)	Thallium, total (mg/L)
MW-17	8/31/2016	<0.002	<0.001	0.0489	<0.001	<0.001	<0.002	0.00177	<1	<0.001	<0.00959	<0.0002	0.00715	0.533	<0.005	<0.001
MW-17	9/26/2016	<0.002	<0.001	0.0537	<0.001	<0.001	<0.002	0.00189	<1	<0.001	<0.00959	<0.0002	0.00825	0.802	<0.005	<0.001
MW-17	10/12/2016	<0.002	<0.001	0.0532	<0.001	<0.001	<0.002	0.00203	<1	0.0015	<0.00959	<0.0002	0.009	0.363	<0.005	<0.001
MW-17	11/16/2016	<0.002	<0.001	0.0642	<0.001	<0.001	<0.002	0.00159	<1	<0.001	<0.00959	<0.0002	0.0096	0.403	<0.005	<0.001
MW-17	12/12/2016	<0.002	<0.001	0.0599	<0.001	<0.001	<0.002	0.00188	<1	<0.001	<0.00959	<0.0002	0.0095	0.781	<0.005	<0.001
MW-17	3/9/2017	<0.002	<0.001	0.0423	<0.001	<0.001	<0.002	0.00102	<1	<0.001	<0.00959	<0.0002	<0.005	0.264	<0.005	<0.001
MW-17	6/8/2017	0.00232	<0.001	0.0498	<0.001	<0.001	<0.002	0.00109	<1	<0.001	<0.00959	<0.0002	<0.005	0.266	<0.005	<0.001
MW-17	7/13/2017	<0.002	<0.001	0.0468	<0.001	<0.001	<0.002	0.00117	<1	<0.001	<0.00959	<0.0002	<0.005	0.246	<0.005	<0.001
MW-17	11/13/2017	NA	NA	NA	NA	NA	NA	NA	<1	NA	NA	NA	NA	NA	NA	NA
MW-17	5/9/2018	<0.003	<0.005	<0.2	<0.004	<0.005	<0.005	<0.005	<1	<0.005	<0.04	<0.0002	<0.01	0.650	<0.01	<0.002
MW-17	9/19/2018	NA	NA	NA	NA	NA	NA	NA	<1	NA	NA	NA	NA	0.359	NA	NA
MW-17	3/15/2019	<0.002	<0.001	0.0619	<0.001	<0.001	<0.002	0.000964	<1	<0.001	<0.005	<0.0002	<0.005	0.150	<0.005	<0.001
MW-17	9/12/2019	NA	<0.001	0.0815	NA	<0.001	0.00243	0.00139	<1	<0.001	0.0175	NA	<0.005	0.658	<0.005	NA
MW-17	4/10/2020	<0.004	<0.002	0.0602	<0.002	<0.001	<0.002	<0.002	0.162	<0.005	0.00536	<0.0002	<0.005	0.806	0.00204	<0.002
MW-18	8/31/2016	<0.002	<0.001	0.0494	<0.001	<0.001	<0.002	0.00369	<1	<0.001	0.00973	<0.0002	<0.005	0.975	0.0112	<0.001
MW-18	9/26/2016	<0.002	<0.001	0.0471	<0.001	<0.001	<0.002	0.00279	<1	<0.001	<0.00959	<0.0002	<0.005	1.55	0.0142	<0.001
MW-18	10/12/2016	<0.002	<0.001	0.0468	<0.001	<0.001	<0.002	0.00240	<1	0.00106	<0.00959	<0.0002	<0.005	0.394	0.00520	<0.001
MW-18	11/16/2016	<0.002	<0.001	0.0524	<0.001	<0.001	<0.002	0.00231	<1	<0.001	<0.00959	<0.0002	<0.005	0.65	0.0128	<0.001
MW-18	12/12/2016	<0.002	<0.001	0.0550	<0.001	<0.001	<0.002	0.00358	<1	<0.001	<0.00959	<0.0002	<0.005	0.89	0.0134	<0.001
MW-18	3/9/2017	<0.002	<0.001	0.0416	<0.001	<0.001	<0.002	0.00168	<1	<0.001	0.0111	<0.0002	<0.005	0.531	<0.005	<0.001
MW-18	6/8/2017	<0.002	<0.001	0.0475	<0.001	<0.001	<0.002	0.00203	<1	<0.001	0.0121	<0.0002	<0.005	0.489	<0.005	<0.001
MW-18	7/13/2017	<0.002	<0.001	0.0407	<0.001	<0.001	<0.002	0.00172	<1	<0.001	<0.00959	<0.0002	<0.005	0.728	0.00697	<0.001
MW-18	11/13/2017	NA	NA	NA	NA	NA	NA	NA	<1	NA	NA	NA	NA	NA	NA	NA
MW-18	5/9/2018	<0.003	<0.005	<0.2	<0.004	<0.005	<0.005	<0.005	<1	<0.005	<0.04	<0.0002	<0.01	0.405	<0.01	<0.002
MW-18	9/19/2018	NA	NA	NA	NA	NA	NA	NA	<1	NA	NA	NA	NA	0.699	NA	NA
MW-18	3/15/2019	<0.002	<0.001	0.0398	<0.001	<0.001	<0.002	0.00131	<1	<0.001	0.00562	<0.0002	<0.005	0.501	0.0143	<0.001
MW-18	9/12/2019	NA	<0.001	0.0411	NA	<0.001	0.00252	0.00176	<1	<0.001	0.0134	NA	<0.005	0.328	0.0157	NA
MW-18	4/10/2020	<0.004	<0.002	0.0317	<0.002	<0.001	<0.002	<0.002	0.161	<0.005	0.00537	<0.0002	<0.005	0.568	0.0120	<0.002

Notes:

- Abbreviations: mg/L - milligrams per liter; NA - not analyzed; pCi/L - picocurie per liter;

Analytical Results - Appendix III  
Zimmer Gypsum Recycle Pond

Sample Location	Date Sampled	Boron, total (mg/L)	Calcium, total (mg/L)	Chloride, total (mg/L)	Fluoride, total (mg/L)	pH (s.u.)	Sulfate, total (mg/L)	Total Dissolved Solids (mg/L)
<b>Background Wells</b>								
MW-8	12/30/2015	0.0783	108	10.3	0.0766	7.3	52.0	370
MW-8	3/16/2016	0.0359	165	32.4	0.106	7.1	59.1	468
MW-8	6/15/2016	0.0455	114	13.8	<1	7.1	64.4	474
MW-8	9/27/2016	0.0413	119	13.1	<1	7.0	66.0	446
MW-8	12/13/2016	0.0405	128	19.2	<1	7.0	65.2	455
MW-8	3/9/2017	<0.08	114	21.1	<1	8.6	57.3	474
MW-8	6/8/2017	<0.08	118	31.6	<1	7.5	63.4	534
MW-8	7/13/2017	<0.08	109	27.5	<1	6.9	61.1	491
MW-8	11/13/2017	<0.08	113	15.0	<1	6.8	<50	434
MW-8	5/8/2018	<1	127	33.8	<1	7.0	62.8	491
MW-8	9/27/2018	<0.08	121	14.5	<1	7.0	66.5	439
MW-8	3/14/2019	<0.08	117	23.8	<1	6.9	62.5	462
MW-8	9/11/2019	<0.08	129	34.0	<1	6.8	59.5	508
MW-8	4/9/2020	<0.03	122	16.0	<0.15	6.8	65.2	421
<b>Downgradient Wells</b>								
MW-7A	12/30/2015	1.63	135	81.4	0.206	7.0	259	737
MW-7A	3/16/2016	2.82	180	134	0.0655	6.6	444	1090
MW-7A	6/16/2016	0.840	122	90.7	<1	6.8	261	765
MW-7A	9/27/2016	4.51	198	108	<1	6.7	512	1180
MW-7A	12/13/2016	1.41	121	160	<1	6.7	553	721
MW-7A	3/10/2017	6.14	260	156	<1	7.7	682	1870
MW-7A	6/8/2017	1.58	146	78.6	<1	6.7	311	854
MW-7A	7/13/2017	1.22	116	69.1	<1	6.8	247	725
MW-7A	11/14/2017	1.40	118	64.7	<1	6.7	277	718
MW-7A	5/8/2018	1.54	135	63.7	<1	6.8	318	923
MW-7A	9/27/2018	1.57	119	55.7	<1	6.7	205	667
MW-7A	3/13/2019	3.03	175	111	<1	6.5	517	1170
MW-7A	9/11/2019	3.38	159	62.8	<1	7.3	376	912
MW-7A	4/10/2020	2.43	156	62.8	<0.15	7.2	366	876
MW-10	12/29/2015	5.42	135	57.3	0.218	7.7	234	1050
MW-10	3/16/2016	9.05	189	122	0.181	7.1	550	1230
MW-10	6/16/2016	4.91	81.5	146	<1	7.2	409	960
MW-10	9/27/2016	0.270	137	149	<1	7.1	606	1400
MW-10	12/13/2016	6.63	127	221	<1	6.8	527	1190
MW-10	3/10/2017	6.00	103	77.9	<1	7.9	426	1160
MW-10	6/8/2017	5.87	99.7	99.5	<1	6.9	452	1050
MW-10	7/13/2017	4.87	79.1	75.7	<1	7.1	367	883
MW-10	11/14/2017	4.07	126	<150	1.44	6.9	582	1210
MW-10	5/8/2018	5.72	249	146	2.49	6.9	1070	2180
MW-10	9/27/2018	4.89	150	113	1.77	6.9	534	1230
MW-10	3/13/2019	5.90	308	176	2.38	6.7	1420	2390
MW-10	9/12/2019	2.79	140	73.3	1.41	6.8	513	1100
MW-10	4/10/2020	4.38	108	60.5	1.92	7.3	372	845



Analytical Results - Appendix III  
 Zimmer Gypsum Recycle Pond

Sample Location	Date Sampled	Boron, total (mg/L)	Calcium, total (mg/L)	Chloride, total (mg/L)	Fluoride, total (mg/L)	pH (s.u.)	Sulfate, total (mg/L)	Total Dissolved Solids (mg/L)
MW-11	12/29/2015	0.581	176	70.4	0.175	7.0	252	768
MW-11	3/16/2016	0.489	270	126	0.0952	6.8	447	1140
MW-11	6/16/2016	0.572	130	81.1	<1	6.9	170	640
MW-11	9/27/2016	0.444	137	74.8	<1	6.9	196	703
MW-11	12/13/2016	1.45	225	131	<1	6.8	545	1110
MW-11	3/10/2017	0.434	147	66.9	<1	8.1	209	736
MW-11	6/8/2017	0.508	167	69.9	<1	6.8	248	767
MW-11	7/13/2017	0.825	149	66.7	<1	6.8	195	728
MW-11	11/14/2017	0.498	133	68.1	<1	6.8	188	634
MW-11	5/8/2018	<1	139	75.1	<1	7.0	197	793
MW-11	9/27/2018	0.921	164	78.1	<1	6.8	<250	771
MW-11	3/13/2019	0.458	181	58.2	<1	6.7	352	959
MW-11	9/12/2019	0.450	119	45.1	<1	6.9	145	590
MW-11	4/10/2020	0.719	110	48.9	0.170	7.4	135	510

Notes:

1. Abbreviations: mg/L - milligrams per liter; s.u. - standard units.

Analytical Results - Appendix IV  
Zimmer Gypsum Recycle Pond

Sample Location	Date Sampled	Antimony, total (mg/L)	Arsenic, total (mg/L)	Barium, total (mg/L)	Beryllium, total (mg/L)	Cadmium, total (mg/L)	Chromium, total (mg/L)	Cobalt, total (mg/L)	Fluoride, total (mg/L)	Lead, total (mg/L)	Lithium, total (mg/L)	Mercury, total (mg/L)	Molybdenum, total (mg/L)	Radium-226 + Radium 228, tot (pCi/L)	Selenium, total (mg/L)	Thallium, total (mg/L)
<b>Background Wells</b>																
MW-8	12/30/2015	<0.0005	0.00115	0.0378	<0.001	<0.0004	<0.0005	<0.0005	0.0766	<0.0002	<0.008	<0.0001	<0.0005	0.173	<0.0006	<0.0005
MW-8	3/16/2016	<0.00418	<0.00295	0.0681	<0.000875	<0.00025	<0.0025	<0.000543	0.106	<0.000433	0.00635	<0.0001	<0.0025	0.408	<0.00398	<0.00138
MW-8	6/15/2016	<0.002	<0.001	0.0418	<0.001	<0.001	<0.002	<0.0005	<1	<0.001	<0.00959	<0.0002	<0.005	0.0694	<0.005	<0.001
MW-8	9/27/2016	<0.002	<0.001	0.0430	<0.001	<0.001	<0.002	<0.0005	<1	<0.001	<0.00959	<0.0002	<0.005	0.214	<0.005	<0.001
MW-8	12/13/2016	<0.002	<0.001	0.0458	<0.001	<0.001	<0.002	<0.0005	<1	<0.001	<0.00959	<0.0002	<0.005	0.710	<0.005	<0.001
MW-8	3/9/2017	<0.002	<0.001	0.0423	<0.001	<0.001	<0.002	<0.0005	<1	<0.001	<0.00959	<0.0002	<0.005	0.361	<0.005	<0.001
MW-8	6/8/2017	<0.002	<0.001	0.0491	<0.001	<0.001	<0.002	<0.0005	<1	<0.001	<0.00959	<0.0002	<0.005	0.0283	<0.005	<0.001
MW-8	7/13/2017	<0.002	<0.001	0.0447	<0.001	<0.001	<0.002	<0.0005	<1	<0.001	<0.00959	<0.0002	<0.005	0.269	<0.005	<0.001
MW-8	11/13/2017	NA	NA	NA	NA	NA	NA	NA	<1	NA	NA	NA	NA	NA	NA	NA
MW-8	5/8/2018	<0.003	<0.005	<0.2	<0.004	<0.005	<0.005	<0.005	<1	<0.005	<0.04	<0.0002	<0.01	0.182	<0.01	<0.002
MW-8	9/27/2018	NA	<0.001	NA	NA	NA	<0.002	NA	<1	NA	NA	NA	NA	0.215	NA	NA
MW-8	3/14/2019	<0.002	<0.001	0.0454	<0.001	<0.001	0.00201	<0.0005	<1	<0.001	<0.005	<0.0002	<0.005	0.0807	<0.005	<0.001
MW-8	9/11/2019	NA	<0.001	0.0552	<0.001	NA	0.00206	<0.0005	<1	<0.001	0.00754	NA	<0.005	0.261	<0.005	NA
MW-8	4/9/2020	<0.004	<0.002	0.0460	<0.002	<0.001	<0.002	<0.002	<0.15	<0.005	0.00464	<0.0002	<0.005	0.292	<0.002	<0.002
<b>Downgradient Wells</b>																
MW-7A	12/30/2015	<0.0005	0.00217	0.0597	<0.001	<0.0004	<0.0005	0.0126	0.206	<0.0002	<0.008	<0.0001	0.00369	0.174	<0.0006	<0.0005
MW-7A	3/16/2016	0.000634	0.0978	0.0543	<0.001	<0.0004	0.0123	0.00783	0.0655	<0.0002	0.00136	<0.0001	0.0014	0.645	0.00267	<0.0005
MW-7A	6/16/2016	<0.002	<0.001	0.0377	<0.001	<0.001	<0.002	0.00291	<1	<0.001	<0.00959	<0.0002	<0.005	0.256	<0.005	<0.001
MW-7A	9/27/2016	<0.002	<0.001	0.0544	<0.001	<0.001	<0.002	0.00411	<1	<0.001	<0.00959	<0.0002	<0.005	0.471	<0.005	<0.001
MW-7A	12/13/2016	<0.002	<0.001	0.0319	<0.001	<0.001	<0.002	0.00298	<1	<0.001	<0.00959	<0.0002	<0.005	0.377	<0.005	<0.001
MW-7A	3/10/2017	<0.002	<0.001	0.0437	<0.001	<0.001	<0.002	0.00528	<1	<0.001	<0.00959	<0.0002	<0.005	0.190	<0.005	<0.001
MW-7A	6/8/2017	<0.002	<0.001	0.0287	<0.001	<0.001	<0.002	0.00149	<1	<0.001	<0.00959	<0.0002	<0.005	0.347	<0.005	<0.001
MW-7A	7/13/2017	<0.002	<0.001	0.0263	<0.001	<0.001	<0.002	0.00113	<1	<0.001	<0.00959	<0.0002	<0.005	0.821	<0.005	<0.001
MW-7A	11/14/2017	NA	NA	NA	NA	NA	NA	NA	<1	NA	NA	NA	NA	NA	NA	NA
MW-7A	5/8/2018	<0.003	<0.005	<0.2	<0.004	<0.005	0.00755	<0.005	<1	<0.005	<0.04	<0.0002	<0.01	0.522	<0.01	<0.002
MW-7A	9/27/2018	NA	<0.001	NA	NA	NA	0.00207	NA	<1	NA	NA	NA	NA	0.411	NA	NA
MW-7A	3/13/2019	<0.002	<0.001	0.0483	<0.001	<0.001	<0.002	0.00245	<1	<0.001	<0.005	<0.0002	<0.005	0.310	<0.005	<0.001
MW-7A	9/11/2019	NA	<0.001	0.0458	NA	<0.001	<0.002	0.00101	<1	<0.001	0.0124	NA	<0.005	0.436	<0.005	NA
MW-7A	4/10/2020	<0.004	<0.002	0.0371	<0.002	<0.001	<0.002	<0.002	<0.15	<0.005	<0.002	<0.0002	<0.005	0.785	0.00204	<0.002
MW-10	12/29/2015	<0.0005	0.00228	0.130	<0.001	<0.0004	0.00293	0.0100	0.218	<0.0002	<0.008	<0.0001	0.0146	0.434	<0.0006	<0.0005
MW-10	3/16/2016	<0.0005	0.00263	0.114	<0.001	<0.0004	<0.0005	0.00835	0.181	<0.0002	0.00132	<0.0001	0.00750	0.382	<0.0006	<0.0005
MW-10	6/16/2016	<0.002	0.00139	0.0729	<0.001	<0.001	<0.002	0.00410	<1	<0.001	<0.00959	<0.0002	0.00793	0.787	<0.005	<0.001
MW-10	9/27/2016	<0.002	0.00203	0.0577	<0.001	<0.001	<0.002	0.00756	<1	<0.001	0.0103	<0.0002	0.0109	0.521	<0.005	<0.001
MW-10	12/13/2016	<0.002	0.00127	0.0436	<0.001	<0.001	<0.002	0.00883	<1	<0.001	<0.00959	<0.0002	0.00590	0.135	<0.005	<0.001
MW-10	3/10/2017	<0.002	0.00164	0.0564	<0.001	<0.001	<0.002	0.00593	<1	<0.001	<0.00959	<0.0002	0.00513	0.446	<0.005	<0.001
MW-10	6/8/2017	<0.002	0.00286	0.0618	<0.001	<0.001	<0.002	0.00417	<1	<0.001	<0.00959	<0.0002	0.00752	0.487	<0.005	<0.001
MW-10	7/13/2017	<0.002	<0.001	0.0453	<0.001	<0.001	<0.002	0.00371	<1	<0.001	<0.00959	<0.0002	0.00731	1.41	<0.005	<0.001
MW-10	11/14/2017	NA	NA	NA	NA	NA	NA	NA	1.44	NA	NA	NA	NA	NA	NA	NA
MW-10	5/8/2018	<0.003	0.00535	<0.2	<0.004	<0.005	<0.005	<0.005	2.49	<0.005	<0.04	<0.0002	<0.01	0.246	<0.01	<0.002
MW-10	9/27/2018	NA	0.00153	NA	NA	NA	<0.002	NA	1.77	NA	NA	NA	NA	0.294	NA	NA
MW-10	3/13/2019	<0.002	0.00407	0.021	<0.001	<0.001	<0.002	0.00112	2.38	<0.001	0.0187	<0.0002	<0.005	0.363	<0.005	<0.001
MW-10	9/12/2019	NA	0.00501	0.0127	NA	<0.001	<0.002	0.00464	1.41	<0.001	0.0144	NA	0.0105	0.336	<0.005	NA
MW-10	4/10/2020	<0.004	0.00201	<0.02	<0.002	<0.001	<0.002	<0.002	1.92	<0.005	0.00934	<0.0002	0.00628	1.29	<0.002	<0.002

Analytical Results - Appendix IV  
Zimmer Gypsum Recycle Pond

Sample Location	Date Sampled	Antimony, total (mg/L)	Arsenic, total (mg/L)	Barium, total (mg/L)	Beryllium, total (mg/L)	Cadmium, total (mg/L)	Chromium, total (mg/L)	Cobalt, total (mg/L)	Fluoride, total (mg/L)	Lead, total (mg/L)	Lithium, total (mg/L)	Mercury, total (mg/L)	Molybdenum, total (mg/L)	Radium-226 + Radium 228, tot (pCi/L)	Selenium, total (mg/L)	Thallium, total (mg/L)
MW-11	12/29/2015	<0.0005	0.00194	0.00977	<0.001	<0.0004	0.000794	0.00920	0.175	<0.0002	<0.008	<0.0001	0.00471	0.471	<0.0006	<0.0005
MW-11	3/16/2016	<0.0005	0.00350	0.116	<0.001	<0.0004	<0.0005	0.00422	0.0952	<0.0002	0.0014	<0.0001	0.00219	0.523	<0.0006	<0.0005
MW-11	6/16/2016	<0.002	<0.001	0.0539	<0.001	<0.001	<0.002	0.00192	<1	<0.001	<0.00959	<0.0002	<0.005	0.525	<0.005	<0.001
MW-11	9/27/2016	<0.002	<0.001	0.0643	<0.001	<0.001	<0.002	0.00147	<1	<0.001	<0.00959	<0.0002	<0.005	0.891	<0.005	<0.001
MW-11	12/13/2016	<0.002	<0.001	0.0921	<0.001	<0.001	<0.002	0.0019	<1	<0.001	<0.00959	<0.0002	<0.005	0.600	<0.005	<0.001
MW-11	3/10/2017	<0.002	<0.001	0.0585	<0.001	<0.001	<0.002	0.00176	<1	<0.001	<0.00959	<0.0002	<0.005	0.525	<0.005	<0.001
MW-11	6/8/2017	<0.002	0.00166	0.0643	<0.001	<0.001	<0.002	0.00200	<1	<0.001	<0.00959	<0.0002	<0.005	0.347	<0.005	<0.001
MW-11	7/13/2017	<0.002	<0.001	0.0589	<0.001	<0.001	<0.002	0.00172	<1	<0.001	<0.00959	<0.0002	<0.005	0.569	<0.005	<0.001
MW-11	11/14/2017	NA	NA	NA	NA	NA	NA	NA	<1	NA	NA	NA	NA	NA	NA	NA
MW-11	5/8/2018	<0.003	<0.005	<0.2	<0.004	<0.005	<0.005	<0.005	<1	<0.005	<0.04	<0.0002	<0.01	0.457	<0.01	<0.002
MW-11	9/27/2018	NA	<0.001	NA	NA	NA	<0.002	NA	<1	NA	NA	NA	NA	0.294	NA	NA
MW-11	3/13/2019	<0.002	0.00123	0.0764	<0.001	<0.001	<0.002	0.00175	<1	<0.001	<0.005	<0.0002	<0.005	0.531	<0.005	<0.001
MW-11	9/12/2019	NA	0.00109	0.0493	NA	<0.001	<0.002	0.00136	<1	<0.001	0.00609	NA	<0.005	0.105	<0.005	NA
MW-11	4/10/2020	<0.004	<0.002	0.0443	<0.002	<0.001	<0.002	<0.002	0.170	<0.005	<0.002	<0.0002	<0.005	0.955	<0.002	<0.002

Notes:

- Abbreviations: mg/L - milligrams per liter; NA - not analyzed; pCi/L - picocurie per liter;



Analytical Results - Appendix III  
Zimmer D Basin

Sample Location	Date Sampled	Boron, total (mg/L)	Calcium, total (mg/L)	Chloride, total (mg/L)	Fluoride, total (mg/L)	pH (s.u.)	Sulfate, total (mg/L)	Total Dissolved Solids (mg/L)
<b>Background Wells</b>								
MW-1	12/30/2015	0.0720	155	48.5	0.200	7.2	90.1	544
MW-1	3/16/2016	0.0233	206	59.1	0.146	7.1	85.2	583
MW-1	6/16/2016	0.0389	154	59.6	<1	7.0	95.3	648
MW-1	8/31/2016	0.0431	168	73.4	<1	6.4	113	612
MW-1	9/26/2016	0.0349	160	64.9	<1	7.1	93.1	621
MW-1	10/12/2016	0.0634	156	79.2	<1	7.2	112	571
MW-1	11/16/2016	0.0304	162	57.7	<1	6.4	90.6	596
MW-1	12/13/2016	0.0322	165	52.4	<1	7.0	93.3	561
MW-1	3/9/2017	<0.08	150	58.2	<1	8.3	85.9	589
MW-1	6/8/2017	<0.08	171	65.5	<1	7.1	87.0	582
MW-1	7/13/2017	<0.08	144	61.3	<1	7.0	79.0	608
MW-1	11/13/2017	<0.08	150	53.1	<1	6.9	89.1	571
MW-1	5/9/2018	<1	157	71.0	<1	7.0	88.9	631
MW-1	9/27/2018	<0.08	163	62.7	<1	6.9	113	578
MW-1	3/14/2019	<0.08	152	78.7	<1	7.0	90.2	617
MW-1	9/11/2019	<0.08	167	63.1	<1	7.0	90.6	637
MW-1	4/9/2020	0.123	170	80.5	<0.15	6.7	92.3	592
MW-8	12/30/2015	0.0783	108	10.3	0.0766	7.3	52.0	370
MW-8	3/16/2016	0.0359	165	32.4	0.106	7.1	59.1	468
MW-8	6/15/2016	0.0455	114	13.8	<1	7.1	64.4	474
MW-8	9/27/2016	0.0413	119	13.1	<1	7.0	66.0	446
MW-8	12/13/2016	0.0405	128	19.2	<1	7.0	65.2	455
MW-8	3/9/2017	<0.08	114	21.1	<1	8.6	57.3	474
MW-8	6/8/2017	<0.08	118	31.6	<1	7.5	63.4	534
MW-8	7/13/2017	<0.08	109	27.5	<1	6.9	61.1	491
MW-8	11/13/2017	<0.08	113	15.0	<1	6.8	<50	434
MW-8	5/8/2018	<1	127	33.8	<1	7.0	62.8	491
MW-8	9/27/2018	<0.08	121	14.5	<1	7.0	66.5	439
MW-8	3/14/2019	<0.08	117	23.8	<1	6.9	62.5	462
MW-8	9/11/2019	<0.08	129	34.0	<1	6.8	59.5	508
MW-8	4/9/2020	<0.03	122	16.0	<0.15	6.8	65.2	421
MW-12	12/30/2015	0.300	179	27.3	0.145	7.1	127	608
MW-12	3/18/2016	0.220	200	66.0	0.172	6.8	99.8	666
MW-12	6/15/2016	0.273	159	42.4	<1	7.0	137	649
MW-12	9/27/2016	0.276	160	29.5	<1	7.1	110	600
MW-12	12/13/2016	0.241	151	31.0	<1	6.9	88.8	555
MW-12	3/9/2017	0.246	160	42.9	<1	8.4	113	610
MW-12	6/8/2017	0.215	168	39.6	<1	7.0	110	606
MW-12	7/13/2017	0.199	154	35.6	<1	6.9	105	579
MW-12	11/13/2017	0.199	146	30.0	<1	6.8	95.5	550
MW-12	5/9/2018	<1	143	30.7	<1	6.9	104	584
MW-12	9/19/2018	0.272	163	31.9	<1	6.8	104	577
MW-12	3/14/2019	0.256	147	33.2	<1	6.9	106	596
MW-12	9/11/2019	0.204	148	26.6	<1	7.7	90.0	557
MW-12	4/9/2020	0.210	162	32.5	<0.15	6.9	98.3	598

Analytical Results - Appendix III  
Zimmer D Basin

Sample Location	Date Sampled	Boron, total (mg/L)	Calcium, total (mg/L)	Chloride, total (mg/L)	Fluoride, total (mg/L)	pH (s.u.)	Sulfate, total (mg/L)	Total Dissolved Solids (mg/L)
<b>Downgradient Wells</b>								
MW-9	12/30/2015	3.31	331	106	0.152	7.2	944	1770
MW-9	3/17/2016	1.98	363	111	0.139	7.0	789	1680
MW-9	6/15/2016	1.12	235	55.6	<1	7.2	630	1170
MW-9	9/27/2016	0.628	213	38.3	<1	7.2	512	989
MW-9	12/12/2016	1.96	280	71.8	<1	7.0	740	1430
MW-9	3/9/2017	2.65	300	104	<1	8.3	837	1680
MW-9	6/8/2017	0.521	262	72.6	<1	7.0	658	1240
MW-9	7/13/2017	1.30	291	<150	<1	7.1	729	1380
MW-9	11/13/2017	0.869	264	50.7	<1	7.0	650	1190
MW-9	5/9/2018	2.47	360	110	<1	6.9	905	1870
MW-9	9/19/2018	1.62	277	53.5	<1	6.8	658	1320
MW-9	3/14/2019	2.29	299	111	<1	7.0	995	1840
MW-9	9/11/2019	0.737	236	30.7	<1	8.3	495	1190
MW-9	4/9/2020	0.511	270	32.3	<0.15	6.9	589	1160
MW-13	12/29/2015	0.0968	220	13.9	0.280	7.2	328	710
MW-13	3/17/2016	0.0482	165	20.7	0.294	7.2	276	667
MW-13	6/15/2016	0.0739	134	39.9	<1	7.1	256	685
MW-13	9/27/2016	0.0594	163	21.9	<1	7.2	215	672
MW-13	12/13/2016	0.0612	162	19.6	<1	7.1	239	678
MW-13	3/9/2017	<0.08	140	17.3	<1	8.5	267	705
MW-13	6/8/2017	<0.08	154	17.2	<1	7.1	256	683
MW-13	7/13/2017	<0.08	149	15.9	<1	7.2	302	722
MW-13	11/13/2017	<0.08	151	19.0	<1	6.9	<250	667
MW-13	5/9/2018	<1	147	17.2	<1	7.1	236	674
MW-13	9/19/2018	<0.08	167	19.2	<1	6.9	260	732
MW-13	3/14/2019	0.0830	141	18.5	<1	7.1	260	717
MW-13	9/11/2019	<0.08	144	14.4	<1	7.6	146	616
MW-13	4/9/2020	0.0597	166	20.4	0.165	7.0	281	715

Analytical Results - Appendix III  
Zimmer D Basin

Sample Location	Date Sampled	Boron, total (mg/L)	Calcium, total (mg/L)	Chloride, total (mg/L)	Fluoride, total (mg/L)	pH (s.u.)	Sulfate, total (mg/L)	Total Dissolved Solids (mg/L)
MW-14	12/29/2015	0.110	262	<0.7	<0.06	7.3	467	1010
MW-14	3/17/2016	0.0453	245	33.7	0.225	7.2	470	992
MW-14	6/15/2016	0.0595	172	<30	<1	7.1	348	837
MW-14	9/27/2016	0.0661	183	29.6	<1	7.1	303	814
MW-14	12/13/2016	0.0702	196	33.4	<1	7.0	365	905
MW-14	3/9/2017	<0.08	192	29.9	<1	8.4	408	916
MW-14	6/8/2017	<0.08	181	<30	<1	7.0	354	843
MW-14	7/13/2017	<0.08	198	30.8	<1	7.2	477	1020
MW-14	11/13/2017	<0.08	194	30.6	<1	7.0	340	893
MW-14	5/9/2018	<1	199	27.9	<1	7.1	398	947
MW-14	9/19/2018	<0.08	207	31.6	<1	6.9	416	1000
MW-14	3/14/2019	<0.08	186	29.5	<1	7.1	420	946
MW-14	9/11/2019	0.139	181	28.8	<1	7.4	287	836
MW-14	4/9/2020	0.116	213	40.0	0.179	7.4	427	939
MW-15	12/30/2015	0.110	296	31.1	0.298	7.1	505	1100
MW-15	3/18/2016	0.0557	233	34.0	0.290	6.9	447	1110
MW-15	6/15/2016	0.0737	213	34.9	<1	6.9	606	1120
MW-15	9/27/2016	0.0833	237	38.0	<1	7.1	493	1160
MW-15	12/13/2016	0.0816	247	38.2	<1	7.0	522	1140
MW-15	3/9/2017	<0.08	212	32.8	<1	8.4	505	1100
MW-15	6/8/2017	<0.08	226	32.4	<1	7.0	524	1090
MW-15	7/13/2017	<0.08	217	36.6	<1	7.1	549	1120
MW-15	11/13/2017	<0.08	224	36.5	<1	6.8	498	1110
MW-15	5/9/2018	<1	203	31.1	<1	7.0	414	1000
MW-15	9/19/2018	0.0939	240	38.7	<1	6.9	529	1170
MW-15	3/14/2019	0.0807	198	38.6	<1	6.9	486	1090
MW-15	9/11/2019	0.120	241	36.2	<1	7.4	535	1170
MW-15	4/9/2020	0.0790	258	41.1	0.175	7.4	567	1090

Notes:

1. Abbreviations: mg/L - milligrams per liter; s.u. - standard units.



Analytical Results - Appendix IV  
Zimmer D Basin

Sample Location	Date Sampled	Antimony, total (mg/L)	Arsenic, total (mg/L)	Barium, total (mg/L)	Beryllium, total (mg/L)	Cadmium, total (mg/L)	Chromium, total (mg/L)	Cobalt, total (mg/L)	Fluoride, total (mg/L)	Lead, total (mg/L)	Lithium, total (mg/L)	Mercury, total (mg/L)	Molybdenum, total (mg/L)	Radium-226 + Radium 228, tot (pCi/L)	Selenium, total (mg/L)	Thallium, total (mg/L)
<b>Background Wells</b>																
MW-1	12/30/2015	<0.0005	0.00142	0.0655	<0.001	<0.0004	0.00191	<0.0005	0.200	<0.0002	<0.008	<0.0001	<0.0005	0.348	<0.0006	<0.0005
MW-1	3/16/2016	<0.00418	<0.00295	0.0863	<0.000875	<0.00025	<0.0025	<0.000543	0.146	<0.000433	0.0101	<0.0001	<0.0025	0.453	<0.00398	<0.00138
MW-1	6/16/2016	<0.002	<0.001	0.0601	<0.001	<0.001	<0.002	<0.0005	<1	<0.001	<0.00959	<0.0002	<0.005	0.603	<0.005	<0.001
MW-1	8/31/2016	<0.002	<0.001	0.0660	<0.001	<0.001	<0.002	<0.0005	<1	<0.001	0.0102	<0.0002	<0.005	0.0844	<0.005	<0.001
MW-1	9/26/2016	<0.002	<0.001	0.0627	<0.001	<0.001	<0.002	<0.0005	<1	<0.001	<0.00959	<0.0002	<0.005	0.168	<0.005	<0.001
MW-1	10/12/2016	<0.002	<0.001	0.0639	<0.001	<0.001	<0.002	<0.0005	<1	0.00268	<0.01	<0.0002	<0.005	0.489	<0.005	<0.001
MW-1	11/16/2016	<0.002	<0.001	0.0670	<0.001	<0.001	<0.002	<0.0005	<1	<0.001	0.0097	<0.0002	<0.005	0.339	<0.005	<0.001
MW-1	12/13/2016	<0.002	<0.001	0.0629	<0.001	<0.001	<0.002	<0.0005	<1	<0.001	<0.00959	<0.0002	<0.005	0.422	<0.005	<0.001
MW-1	3/9/2017	<0.002	<0.001	0.0587	<0.001	<0.001	<0.002	<0.0005	<1	<0.001	0.0107	<0.0002	<0.005	0.426	<0.005	<0.001
MW-1	6/8/2017	<0.002	<0.001	0.0643	<0.001	<0.001	<0.002	<0.0005	<1	<0.001	0.0116	<0.0002	<0.005	0.349	<0.005	<0.001
MW-1	7/13/2017	<0.002	<0.001	0.0566	<0.001	<0.001	<0.002	<0.0005	<1	<0.001	<0.00959	<0.0002	<0.005	0.144	<0.005	<0.001
MW-1	11/13/2017	NA	NA	NA	NA	NA	NA	NA	<1	NA	NA	NA	NA	NA	NA	NA
MW-1	5/9/2018	<0.003	<0.005	<0.2	<0.004	<0.005	<0.005	<0.005	<1	<0.005	<0.04	<0.0002	<0.01	0.370	<0.01	<0.002
MW-1	9/27/2018	NA	NA	NA	NA	NA	NA	NA	<1	NA	NA	NA	NA	0.231	NA	NA
MW-1	3/14/2019	<0.002	<0.001	0.0665	<0.001	<0.001	0.0023	<0.0005	<1	<0.001	0.00665	<0.0002	<0.005	0.171	<0.005	<0.001
MW-1	9/11/2019	NA	<0.001	0.0770	<0.001	NA	<0.002	<0.0005	<1	<0.001	0.0109	NA	<0.005	0.110	<0.005	NA
MW-1	4/9/2020	<0.004	<0.002	0.0725	<0.002	<0.001	<0.002	<0.002	<0.15	<0.005	0.00964	<0.0002	<0.005	0.0302	<0.002	<0.002
MW-8	12/30/2015	<0.0005	0.00115	0.0378	<0.001	<0.0004	<0.0005	<0.0005	0.0766	<0.0002	<0.008	<0.0001	<0.0005	0.173	<0.0006	<0.0005
MW-8	3/16/2016	<0.00418	<0.00295	0.0681	<0.000875	<0.00025	<0.0025	<0.000543	0.106	<0.000433	0.00635	<0.0001	<0.0025	0.408	<0.00398	<0.00138
MW-8	6/15/2016	<0.002	<0.001	0.0418	<0.001	<0.001	<0.002	<0.0005	<1	<0.001	<0.00959	<0.0002	<0.005	0.0694	<0.005	<0.001
MW-8	9/27/2016	<0.002	<0.001	0.0430	<0.001	<0.001	<0.002	<0.0005	<1	<0.001	<0.00959	<0.0002	<0.005	0.214	<0.005	<0.001
MW-8	12/13/2016	<0.002	<0.001	0.0458	<0.001	<0.001	<0.002	<0.0005	<1	<0.001	<0.00959	<0.0002	<0.005	0.710	<0.005	<0.001
MW-8	3/9/2017	<0.002	<0.001	0.0423	<0.001	<0.001	<0.002	<0.0005	<1	<0.001	<0.00959	<0.0002	<0.005	0.361	<0.005	<0.001
MW-8	6/8/2017	<0.002	<0.001	0.0491	<0.001	<0.001	<0.002	<0.0005	<1	<0.001	<0.00959	<0.0002	<0.005	0.0283	<0.005	<0.001
MW-8	7/13/2017	<0.002	<0.001	0.0447	<0.001	<0.001	<0.002	<0.0005	<1	<0.001	<0.00959	<0.0002	<0.005	0.269	<0.005	<0.001
MW-8	11/13/2017	NA	NA	NA	NA	NA	NA	NA	<1	NA	NA	NA	NA	NA	NA	NA
MW-8	5/8/2018	<0.003	<0.005	<0.2	<0.004	<0.005	<0.005	<0.005	<1	<0.005	<0.04	<0.0002	<0.01	0.182	<0.01	<0.002
MW-8	9/27/2018	NA	<0.001	NA	NA	NA	<0.002	NA	<1	NA	NA	NA	NA	0.215	NA	NA
MW-8	3/14/2019	<0.002	<0.001	0.0454	<0.001	<0.001	0.00201	<0.0005	<1	<0.001	<0.005	<0.0002	<0.005	0.0807	<0.005	<0.001
MW-8	9/11/2019	NA	<0.001	0.0552	<0.001	NA	0.00206	<0.0005	<1	<0.001	0.00754	NA	<0.005	0.261	<0.005	NA
MW-8	4/9/2020	<0.004	<0.002	0.0460	<0.002	<0.001	<0.002	<0.002	<0.15	<0.005	0.00464	<0.0002	<0.005	0.292	<0.002	<0.002
MW-12	12/30/2015	<0.0005	0.00169	0.0697	<0.001	<0.0004	0.000518	<0.0005	0.145	<0.0002	<0.008	<0.0001	<0.0005	0.318	0.00131	<0.0005
MW-12	3/18/2016	<0.00418	<0.00295	0.0813	<0.000875	<0.00025	<0.0025	<0.000543	0.172	<0.000433	0.00875	<0.0001	<0.0025	0.510	<0.00398	<0.00138
MW-12	6/15/2016	<0.002	<0.001	0.0605	<0.001	<0.001	<0.002	<0.0005	<1	<0.001	<0.00959	<0.0002	<0.005	0.130	<0.005	<0.001
MW-12	9/27/2016	<0.002	<0.001	0.0614	<0.001	<0.001	<0.002	<0.0005	<1	<0.001	<0.00959	<0.0002	<0.005	1.11	<0.005	<0.001
MW-12	12/13/2016	<0.002	<0.001	0.0588	<0.001	<0.001	<0.002	<0.0005	<1	<0.001	<0.00959	<0.0002	<0.005	0.375	<0.005	<0.001
MW-12	3/9/2017	<0.002	<0.001	0.0563	<0.001	<0.001	<0.002	<0.0005	<1	<0.001	<0.00959	<0.0002	<0.005	0.429	<0.005	<0.001
MW-12	6/8/2017	<0.002	<0.001	0.0618	<0.001	<0.001	<0.002	<0.0005	<1	<0.001	<0.00959	<0.0002	<0.005	0.182	<0.005	<0.001
MW-12	7/13/2017	<0.002	<0.001	0.0579	<0.001	<0.001	<0.002	<0.0005	<1	<0.001	<0.00959	<0.0002	<0.005	0.288	<0.005	<0.001
MW-12	11/13/2017	NA	NA	NA	NA	NA	NA	NA	<1	NA	NA	NA	NA	NA	NA	NA
MW-12	5/9/2018	<0.003	<0.005	<0.2	<0.004	<0.005	<0.005	<0.005	<1	<0.005	<0.04	<0.0002	<0.01	0.411	<0.01	<0.002
MW-12	9/19/2018	NA	NA	NA	NA	NA	NA	NA	<1	NA	NA	NA	NA	0.522	NA	NA
MW-12	3/14/2019	<0.002	<0.001	0.0631	<0.001	<0.001	0.00218	<0.0005	<1	<0.001	0.00543	<0.0002	<0.005	0.247	<0.005	<0.001
MW-12	9/11/2019	NA	<0.001	0.0692	<0.001	NA	0.00249	<0.0005	<1	<0.001	0.0114	NA	<0.005	0.118	<0.005	NA
MW-12	4/9/2020	<0.004	<0.002	0.0657	<0.002	<0.001	<0.002	<0.002	<0.15	<0.005	0.00591	<0.0002	<0.005	3.90	<0.002	<0.002

Analytical Results - Appendix IV  
Zimmer D Basin

Sample Location	Date Sampled	Antimony, total (mg/L)	Arsenic, total (mg/L)	Barium, total (mg/L)	Beryllium, total (mg/L)	Cadmium, total (mg/L)	Chromium, total (mg/L)	Cobalt, total (mg/L)	Fluoride, total (mg/L)	Lead, total (mg/L)	Lithium, total (mg/L)	Mercury, total (mg/L)	Molybdenum, total (mg/L)	Radium-226 + Radium 228, tot (pCi/L)	Selenium, total (mg/L)	Thallium, total (mg/L)
<b>Downgradient Wells</b>																
MW-9	12/30/2015	<0.0005	0.00454	0.0450	<0.001	0.000721	0.00159	0.00327	0.152	0.00021	0.00836	<0.0001	0.00145	0.649	<0.0006	<0.0005
MW-9	3/17/2016	<0.00418	<0.00295	0.0567	<0.000875	<0.00025	<0.0025	0.00406	0.139	<0.000433	0.011	<0.0001	<0.0025	0.637	<0.00398	<0.00138
MW-9	6/15/2016	<0.002	0.00127	0.0253	<0.001	<0.001	<0.002	0.00253	<1	<0.001	<0.00959	<0.0002	<0.005	0.573	<0.005	<0.001
MW-9	9/27/2016	<0.002	0.00140	0.0239	<0.001	<0.001	<0.002	0.00202	<1	<0.001	<0.00959	<0.0002	<0.005	0.841	<0.005	<0.001
MW-9	12/12/2016	<0.002	0.00151	0.0269	<0.001	<0.001	<0.002	0.00299	<1	<0.001	<0.00959	<0.0002	<0.005	1.07	<0.005	<0.001
MW-9	3/9/2017	<0.002	0.00161	0.0330	<0.001	<0.001	<0.002	0.00403	<1	<0.001	0.0126	<0.0002	<0.005	0.358	<0.005	<0.001
MW-9	6/8/2017	<0.002	0.00257	0.0337	<0.001	<0.001	<0.002	0.00219	<1	<0.001	0.0124	<0.0002	<0.005	0.32	<0.005	<0.001
MW-9	7/13/2017	<0.002	0.00178	0.0308	<0.001	<0.001	<0.002	0.00292	<1	<0.001	0.0116	<0.0002	<0.005	0.729	<0.005	<0.001
MW-9	11/13/2017	NA	NA	NA	NA	NA	NA	NA	<1	NA	NA	NA	NA	NA	NA	NA
MW-9	5/9/2018	<0.003	<0.005	<0.2	<0.004	<0.005	<0.005	<0.005	<1	<0.005	<0.04	<0.0002	<0.01	0.446	<0.01	<0.002
MW-9	9/19/2018	NA	NA	NA	NA	NA	NA	NA	<1	NA	NA	NA	NA	0.342	NA	NA
MW-9	3/14/2019	<0.002	0.00171	0.0333	<0.001	<0.001	<0.002	0.00351	<1	<0.001	0.00779	<0.0002	<0.005	0.323	<0.005	<0.001
MW-9	9/11/2019	NA	0.00188	0.0261	<0.001	NA	0.00237	0.00267	<1	<0.001	0.0135	NA	<0.005	0.372	<0.005	NA
MW-9	4/9/2020	<0.004	<0.002	0.0260	<0.002	<0.001	<0.002	0.00286	<0.15	<0.005	0.00709	<0.0002	<0.005	6.29	<0.002	<0.002
MW-13	12/29/2015	0.000841	0.00260	0.0564	<0.001	<0.0004	<0.0005	0.00653	0.280	<0.0002	<0.008	<0.0001	0.00495	0.574	0.000664	<0.0005
MW-13	3/17/2016	<0.00418	0.00480	0.0691	<0.000875	<0.00025	<0.0025	0.00516	0.294	<0.000433	0.00426	<0.0001	0.00674	0.425	<0.00398	<0.00138
MW-13	6/15/2016	<0.002	0.00264	0.0521	<0.001	<0.001	<0.002	0.00641	<1	<0.001	<0.00959	<0.0002	<0.005	0.459	<0.005	<0.001
MW-13	9/27/2016	<0.002	0.00460	0.0524	<0.001	<0.001	<0.002	0.00514	<1	<0.001	<0.00959	<0.0002	<0.005	0.612	<0.005	<0.001
MW-13	12/13/2016	<0.002	0.00324	0.0536	<0.001	<0.001	<0.002	0.00477	<1	<0.001	<0.00959	<0.0002	0.005	0.646	<0.005	<0.001
MW-13	3/9/2017	<0.002	0.00348	0.0516	<0.001	<0.001	<0.002	0.00348	<1	<0.001	<0.00959	<0.0002	<0.005	0.235	<0.005	<0.001
MW-13	6/8/2017	<0.002	0.00319	0.0503	<0.001	<0.001	<0.002	0.00237	<1	<0.001	<0.00959	<0.0002	<0.005	0.284	<0.005	<0.001
MW-13	7/13/2017	<0.002	0.00222	0.0446	<0.001	<0.001	<0.002	0.00244	<1	<0.001	<0.00959	<0.0002	<0.005	0.841	<0.005	<0.001
MW-13	11/13/2017	NA	NA	NA	NA	NA	NA	NA	<1	NA	NA	NA	NA	NA	NA	NA
MW-13	5/9/2018	<0.003	<0.005	<0.2	<0.004	<0.005	<0.005	<0.005	<1	<0.005	<0.04	<0.0002	<0.01	0.565	<0.01	<0.002
MW-13	9/19/2018	NA	NA	NA	NA	NA	NA	NA	<1	NA	NA	NA	NA	0.478	NA	NA
MW-13	3/14/2019	<0.002	0.0183	0.0540	<0.001	<0.001	<0.002	0.00295	<1	<0.001	<0.005	<0.0002	<0.005	0.284	<0.005	<0.001
MW-13	9/11/2019	NA	0.00525	0.0461	<0.001	NA	0.00231	0.00368	<1	<0.001	0.00811	NA	<0.005	0.449	<0.005	NA
MW-13	4/9/2020	<0.004	0.00261	0.0477	<0.002	<0.001	<0.002	0.00297	0.165	<0.005	0.00266	<0.0002	<0.005	3.43	<0.002	<0.002

Analytical Results - Appendix IV  
Zimmer D Basin

Sample Location	Date Sampled	Antimony, total (mg/L)	Arsenic, total (mg/L)	Barium, total (mg/L)	Beryllium, total (mg/L)	Cadmium, total (mg/L)	Chromium, total (mg/L)	Cobalt, total (mg/L)	Fluoride, total (mg/L)	Lead, total (mg/L)	Lithium, total (mg/L)	Mercury, total (mg/L)	Molybdenum, total (mg/L)	Radium-226 + Radium 228, tot (pCi/L)	Selenium, total (mg/L)	Thallium, total (mg/L)
MW-14	12/29/2015	0.00067	0.00263	0.0509	<0.001	<0.0004	<0.0005	0.00857	<0.06	0.000291	<0.008	<0.0001	0.00142	0.594	<0.0006	<0.0005
MW-14	3/17/2016	<0.00418	<0.00295	0.0641	<0.000875	<0.00025	<0.0025	0.00514	0.225	<0.000433	0.00379	<0.0001	0.00276	0.957	<0.00398	<0.00138
MW-14	6/15/2016	<0.002	0.00171	0.0480	<0.001	<0.001	<0.002	0.00547	<1	<0.001	<0.00959	<0.0002	<0.005	0.534	<0.005	<0.001
MW-14	9/27/2016	<0.002	0.00163	0.0464	<0.001	<0.001	<0.002	0.00435	<1	<0.001	<0.00959	<0.0002	<0.005	0.496	<0.005	<0.001
MW-14	12/13/2016	<0.002	0.00173	0.0535	<0.001	<0.001	<0.002	0.00563	<1	<0.001	<0.00959	<0.0002	<0.005	1.36	<0.005	<0.001
MW-14	3/9/2017	<0.002	0.00168	0.0465	<0.001	<0.001	<0.002	0.00367	<1	<0.001	<0.00959	<0.0002	<0.005	0.444	<0.005	<0.001
MW-14	6/8/2017	<0.002	0.00158	0.0465	<0.001	<0.001	<0.002	0.00278	<1	<0.001	<0.00959	<0.0002	<0.005	0.318	<0.005	<0.001
MW-14	7/13/2017	<0.002	0.00124	0.0440	<0.001	<0.001	<0.002	0.00231	<1	<0.001	<0.00959	<0.0002	<0.005	0.689	<0.005	<0.001
MW-14	11/13/2017	NA	NA	NA	NA	NA	NA	NA	<1	NA	NA	NA	NA	NA	NA	NA
MW-14	5/9/2018	<0.003	<0.005	<0.2	<0.004	<0.005	<0.005	<0.005	<1	<0.005	<0.04	<0.0002	<0.01	0.618	<0.01	<0.002
MW-14	9/19/2018	NA	NA	NA	NA	NA	NA	NA	<1	NA	NA	NA	NA	0.933	NA	NA
MW-14	3/14/2019	<0.002	<0.001	0.0507	<0.001	<0.001	0.00213	0.00229	<1	<0.001	<0.005	<0.0002	<0.005	0.229	<0.005	<0.001
MW-14	9/11/2019	NA	0.00155	0.0554	<0.001	NA	0.00254	0.00239	<1	<0.001	0.00843	NA	<0.005	1.94	<0.005	NA
MW-14	4/9/2020	<0.004	<0.002	0.0501	<0.002	<0.001	<0.002	0.00223	0.179	<0.005	0.00236	<0.0002	<0.005	1.6	<0.002	<0.002
MW-15	12/30/2015	0.000823	0.00265	0.0896	<0.001	<0.0004	<0.0005	0.0109	0.298	<0.0002	<0.008	<0.0001	0.00554	0.59	<0.0006	<0.0005
MW-15	3/18/2016	<0.00418	<0.00295	0.0835	<0.000875	<0.00025	<0.0025	0.00798	0.290	<0.000433	0.00298	<0.0001	0.00495	0.419	<0.00398	<0.00138
MW-15	6/15/2016	<0.002	<0.001	0.0687	<0.001	<0.001	<0.002	0.00751	<1	<0.001	<0.00959	<0.0002	<0.005	0.735	<0.005	<0.001
MW-15	9/27/2016	<0.002	<0.001	0.0773	<0.001	<0.001	<0.002	0.00778	<1	<0.001	<0.00959	<0.0002	<0.005	1.26	<0.005	<0.001
MW-15	12/13/2016	<0.002	<0.001	0.0767	<0.001	<0.001	<0.002	0.00701	<1	<0.001	<0.00959	<0.0002	0.00524	0.936	<0.005	<0.001
MW-15	3/9/2017	<0.002	<0.001	0.0677	<0.001	<0.001	<0.002	0.00593	<1	<0.001	<0.00959	<0.0002	<0.005	0.556	<0.005	<0.001
MW-15	6/8/2017	<0.002	<0.001	0.0663	<0.001	<0.001	<0.002	0.00353	<1	<0.001	<0.00959	<0.0002	<0.005	0.474	<0.005	<0.001
MW-15	7/13/2017	<0.002	<0.001	0.0676	<0.001	<0.001	<0.002	0.00427	<1	<0.001	<0.00959	<0.0002	<0.005	0.554	<0.005	<0.001
MW-15	11/13/2017	NA	NA	NA	NA	NA	NA	NA	<1	NA	NA	NA	NA	NA	NA	NA
MW-15	5/9/2018	<0.003	<0.005	<0.2	<0.004	<0.005	<0.005	<0.005	<1	<0.005	<0.04	<0.0002	<0.01	0.707	<0.01	<0.002
MW-15	9/19/2018	NA	NA	NA	NA	NA	NA	NA	<1	NA	NA	NA	NA	1.08	NA	NA
MW-15	3/14/2019	<0.002	<0.001	0.0600	<0.001	<0.001	<0.002	0.00318	<1	<0.001	<0.005	<0.0002	<0.005	0.783	<0.005	<0.001
MW-15	9/11/2019	NA	<0.001	0.0836	<0.001	NA	0.00257	0.00381	<1	<0.001	0.00845	NA	<0.005	0.756	<0.005	NA
MW-15	4/9/2020	<0.004	<0.002	0.0663	<0.002	<0.001	<0.002	0.00374	0.175	<0.005	0.00213	<0.0002	<0.005	3.26	<0.002	<0.002

Notes:

- Abbreviations: mg/L - milligrams per liter; NA - not analyzed; pCi/L - picocurie per liter;



**APPENDIX C5 – SITE HYDROGEOLOGY AND STRATIGRAPHIC CROSS-  
SECTIONS OF THE SITE**

## CONCEPTUAL SITE MODEL AND DESCRIPTION OF SITE HYDROGEOLOGY (ASH POND AREAS)

The Zimmer Power Station (Zimmer Station) conceptual site model (CSM) and Description of Site Hydrogeology for the D Basin, the Gypsum Recycling Pond, and the Coal Pile Runoff Pond, hereinafter referred to as the 'Site', located near Moscow, Ohio are described in the following sections.

### REGIONAL SETTING

The Ohio River Valley generally separates the Till Plains Section of the Central Lowlands Physiographic Province from the Lexington Plain Section of the Interior Low Plateaus Physiographic Province. The Central Lowlands Physiographic Province is characterized by plains of low relief with youthful to mature dissection developed on soil and rock deposits. The Till Plains Section is generally north of the Ohio River and is characterized by hills of low relief that are developed on nearly horizontal, Paleozoic sedimentary strata. Continental glaciation has affected most of the province so that bedrock is almost entirely concealed by glacial drift. Common valley fill material consists of coarse-grained outwash deposits, fine-grained lacustrine and overbank deposits, and glacial till. The bedrock consists of interbedded shales and limestones typical of the Cincinnati Series.

### SITE GEOLOGY

Zimmer Station is located on the relatively flat floor of the Ohio River Valley and is underlain by valley-fill glacial deposits. Glacial deposits directly beneath Zimmer Station consist of fine-grained fluvial and lacustrine deposits (clay and silt) to a maximum depth of 45 feet below the present ground surface. These deposits are underlain by coarser alluvial deposits that are composed of well-graded to poorly-graded sands having greater amounts of gravel with increasing depth. Bedrock beneath the unconsolidated sediments belongs to the Fairview and Kope formations. Depth to bedrock beneath the site varies between 60 and 90 feet below the ground surface.

Cross-sections showing the subsurface materials encountered at the Site are included in an attachment to this demonstration.

### SITE HYDROGEOLOGY

The CCR groundwater monitoring system consists of the follow:

- Seven monitoring wells are installed in the uppermost aquifer and adjacent to the D Basin (MW-1, MW-8, MW-9, MW-12, MW-13, MW-14 and MW-15). The unit utilizes three background monitoring wells (MW-1, MW-8 and MW-12) as part of the CCR groundwater monitoring system.
- Four monitoring wells are installed in the uppermost aquifer and adjacent to the Gypsum Recycling Pond (MW-7A, MW-8, MW-10 and MW-11). The unit utilizes one background monitoring wells (MW-8) as part of the CCR groundwater monitoring system.
- Five monitoring wells are installed in the uppermost aquifer and adjacent to the Coal Pile Runoff Pond (MW-1, MW-3S, MW-16, MW-17 and MW-18). The unit utilizes one background monitoring wells (MW-1) as part of the CCR groundwater monitoring system.

See Monitoring Well Location Map, and Well Construction Diagrams and Drilling Logs attached to this demonstration.

Groundwater is encountered in the Ohio River valley aquifer. The aquifer consists primarily of the coarser alluvial deposits described above. The thickness of the deposits ranges from approximately 50 to 65 feet and covers much of the width of the flood plain between the river and Route 52 located to the east. Porosity of the aquifer material is likely to be on the order of 20 to 40 percent given the distribution of grain sizes. The groundwater potentiometric surface on site is encountered at depths of 25 to 50 feet below ground surface (bgs) (approximately 455 to 470 feet above mean sea level [msl]). The large variability is introduced by rising and falling river stage because of a relatively direct hydraulic connection between the riverbed and the aquifer.

The aquifer receives most of its recharge from infiltration of precipitation on the valley floor; however, secondary recharge sources include adjacent upgradient aquifers in the upland, and bank storage from the Ohio River during flood stages. Recharge to the aquifer from bank storage is periodic and short-lived, and the main movement of groundwater discharge is toward the river.

Zimmer Station withdraws water from the underlying sand and gravel aquifer through eight onsite production wells, all of which are located on the southern half of the facility. In general, each of the production wells is capable of yielding between 0.720 and 0.432 million gallons per day (mgd); however, the average daily yield is approximately 0.206 mgd.

When pumping, a localized cone of depression in the groundwater surface is created that encompasses the southern and, occasionally, the central portion of the site (AEP, November, 1986). This cone of depression induces flow from the Ohio River toward the pumping wells. The hydraulic gradient of the aquifer was calculated to be on the order of 0.0025 toward the Ohio River with a west-northwest to west southwest direction. The transmissivity of the aquifer is approximately 50,000 gallons per day per foot (gpd/ft), the hydraulic conductivity is approximately 1,000 gpd/ft<sup>2</sup> (134 ft/day), and the storage coefficient of the aquifer is 0.17 (Wm. H. Zimmer, 1983).

Material overlying the uppermost aquifer directly beneath Zimmer Station is comprised of glacial deposits consisting of fine-grained fluvial and lacustrine deposits (clay and silt) to a maximum depth of 45 feet bgs. Permeability tests conducted on in-situ cohesive material by American Electric Power Service Corporation, Civil Engineering Division in 1986 suggested values in the range of  $9.7 \times 10^{-9}$  to  $1.4 \times 10^{-8}$  cm/sec.

The lower confining unit underlying Zimmer Station is bedrock consisting of interbedded shales and limestones belonging to the Fairview and Kope formations. Depth to bedrock beneath the site varies between 60 and 90 feet bgs. These low-yielding shale and limestone formations are approximately 400- to 600-feet thick (Luft, et. al., 1973). Groundwater yields from the bedrock strata in this region are quite limited. Generally, the bedrock is not tapped for water due to its low permeability. Those wells which do tap the bedrock aquifers generally draw water from the bedding planes and fracture zones. Due to the relatively impermeable nature of the shales and limestone underlying this region, water yields are generally insufficient for domestic use. Fresh water does not typically occur at depths greater than 150 feet bgs (Wm. H. Zimmer, 1983).

## REFERENCES

American Electric Power Service Corporation, Civil Engineering Division, November 1986, Geotechnical report for the WM. H. Zimmer Coal Conversion Project.

Luft, Stanley J.1 Osborne, Robert H., and Malcolm P. Weiss. Geologic Map of the Moscow Quadrangle, Ohio - Kentucky (GQ-1069). Prepared in cooperation with The Commonwealth of Kentucky, University of Kentucky, Kentucky Geological Survey, 1973.





Zimmer, William. H., 1983, Nuclear Power Station Unit 1 Environmental Report Operating License Stage, Volume 1, Section Number 245.



Service Layer Credits: Source: Esri, DeLorme, GeoEye, Earthstar, Imagery, CNES, Airbus DS, USDA, USGS, AeroGRID, IGN, and the GIS User Community

- CCR MONITORING WELL LOCATION
- TEST BORING LOCATION
- CROSS SECTION LOCATION
- CCR MONITORED UNIT

### CROSS SECTION LOCATION MAP

ZIMMER D BASIN (UNIT ID: 121),  
 ZIMMER GYPSUM RECYCLE POND (UNIT ID: 124) AND  
 ZIMMER COAL PILE RUNOFF POND (UNIT ID: 125)  
 ZIMMER POWER STATION  
 MOSCOW, OHIO

RAMBOLL US CORPORATION  
 A RAMBOLL COMPANY











## **APPENDIX C6 – STRUCTURAL STABILITY ASSESSMENT**





Submitted to  
Zimmer Power Station  
1781 US Route 52  
Moscow, OH 45153

Submitted by  
AECOM  
1001 Highlands Plaza Drive West  
Suite 300  
St. Louis, MO 63110

October 2016

# CCR Rule Report: Initial Structural Stability Assessment

For

Coal Pile Runoff Pond

At Zimmer Power Station

# 1 Introduction

This Coal Combustion Residual (CCR) Rule Report documents that the Coal Pile Runoff Pond at the Zimmer Power Station meets the structural stability assessment requirements specified in 40 Code of Federal Regulations (CFR) §257.73(d). The Coal Pile Runoff Pond is located near Moscow, Ohio in Clermont County, approximately 0.6 miles north of the Zimmer Power Station. The Coal Pile Runoff Pond receives leachate from the Zimmer Power Station's on-site landfill, discharge from the Chemical Metal Cleaning waste treatment tank, and pumped flows from the D Basin CCR surface impoundment and other non-CCR ponds at Zimmer Power Station.

The Coal Pile Runoff Pond is an existing CCR surface impoundment as defined by 40 CFR §257.53. The CCR Rule requires that an initial structural stability assessment for an existing CCR surface impoundment be completed by October 17, 2016. In general, the initial structural stability assessment must document that the design, construction, operation, and maintenance of the CCR unit is consistent with recognized and generally accepted good engineering practices.

The owner or operator of the CCR unit must obtain a certification from a qualified professional engineer stating that the initial structural stability assessment was conducted in accordance with the requirements of 40 CFR § 257.73(d). The owner or operator must prepare a periodic structural stability assessment every five years.

## 2 Initial Structural Stability Assessment

### *40 CFR §257.73(d)(1)*

*The owner or operator of the CCR unit must conduct initial and periodic structural stability assessments and document whether the design, construction, operation, and maintenance of the CCR unit is consistent with recognized and generally accepted good engineering practices for the maximum volume of CCR and CCR wastewater which can be impounded therein. The assessment must, at a minimum, document whether the CCR unit has been designed, constructed, operated, and maintained with [the standards in (d)(1)(i)-(vii)].*

An initial structural stability assessment has been performed to document that the design, construction, operation and maintenance of the Coal Pile Runoff Pond is consistent with recognized and generally accepted good engineering practices and meets the standards in 257.73(d)(1)(i)-(vii). The results of the structural stability assessment are discussed in the following sections. Based on the assessment and its results, the design, construction, operation, and maintenance of the Coal Pile Runoff Pond were found to be consistent with recognized and generally accepted good engineering practices.

### **2.1 Foundations and Abutments (§257.73(d)(1)(i))**

*CCR unit designed, constructed, operated, and maintained with stable foundations and abutments.*

The stability of the foundations was evaluated using soil data from field investigations and reviewing design drawings, information about operations and maintenance, and conditions observed in the field by AECOM. Additionally, slope stability analyses were performed to evaluate slip surfaces passing through the foundations. The Coal Pile Runoff Pond is a ring dike structure and does not have abutments.

The foundation consists of medium stiff to hard clay soil, underlain by loose to very dense sand, which indicates stable foundations. Slope stability analyses exceed the criteria listed in §257.73(e)(1) for slip surfaces passing through the foundation. The slope stability analyses are discussed in the *CCR Rule Report: Initial Safety Factor Assessment for Coal Pile Runoff Pond at Zimmer Power Station* (October 2016). A review of information about operations and maintenance as well as current and past performance of the dikes has determined appropriate processes are in place for continued operational performance.

Based on the conditions observed by AECOM, the Coal Pile Runoff Pond was designed and constructed with stable foundations. Any issues related to the stability of the foundation is addressed during operations and maintenance; therefore, the Coal Pile Runoff Pond meets the requirements in §257.73(d)(1)(i).

### **2.2 Slope Protection (§257.73(d)(1)(ii))**

*CCR unit designed, constructed, operated, and maintained with adequate slope protection to protect against surface erosion, wave action and adverse effects of sudden drawdown.*

The adequacy of slope protection was evaluated by reviewing design drawings, information about operations and maintenance, and conditions observed in the field by AECOM.

Based on this evaluation, adequate slope protection was designed and constructed at the Coal Pile Runoff Pond. No evidence of significant areas of erosion or wave action were observed and slopes were covered in vegetation. The Zimmer Power Station regularly maintains the slopes, including repairing observed surface erosion and addressing areas of poor vegetation growth, as required. Due to the characteristics of the outfall structure for the



Coal Pile Runoff Pond, sudden drawdown conditions are not expected to occur on the interior slopes. Therefore, the Coal Pile Runoff Pond meets the requirements in §257.73(d)(1)(ii).

### **2.3 Dike Compaction (§257.73(d)(1)(iii))**

*CCR unit designed, constructed, operated, and maintained with dikes mechanically compacted to a density sufficient to withstand the range of loading conditions in the CCR unit.*

The density of the dike materials was evaluated using soil data from field investigations and reviewing design drawings, information about operations and maintenance, and conditions observed in the field by AECOM. Additionally, slope stability analyses were performed to evaluate slip surfaces passing through the dike over the range of expected loading conditions as defined within §257.73(e)(1).

Based on this evaluation, the dike consists of very stiff to hard clay material, which is indicative of mechanically compacted dikes. Slope stability analyses exceed the criteria listed in §257.73(e)(1) for slip surfaces passing through the dike. The slope stability analyses are discussed in the *CCR Rule Report: Initial Safety Factor Assessment for Coal Pile Runoff Pond at Zimmer Power Station* (October 2016); therefore, the original design and construction of the Coal Pile Runoff Pond included sufficient dike compaction. Deficiencies related to compaction of the dikes are identified and mitigated as part of operations and maintenance, in order to maintain sufficient compaction and density of the dikes to withstand the range of loading conditions. Therefore, the Coal Pile Runoff Pond meets the requirements in §257.73(d)(1)(iii).

### **2.4 Vegetated Slopes (§257.73(d)(1)(iv))<sup>1</sup>**

*CCR unit designed, constructed, operated, and maintained with vegetated slopes of dikes and surrounding areas, except for slopes which have an alternate form or forms of slope protection.*

The adequacy of slope vegetation was evaluated by reviewing design drawings, information about operations and maintenance, and conditions observed in the field by AECOM.

Based on this evaluation, the vegetation on the interior and exterior slopes is adequate as no substantial bare or overgrown areas were observed. Therefore, the original design and construction of the Coal Pile Runoff Pond included adequate vegetation of the dikes and surrounding areas. Adequate operational and maintenance practices are in place to regularly manage vegetation growth, including mowing and seeding any bare areas, as evidenced by the conditions observed by AECOM. Therefore, the Coal Pile Runoff Pond meets the requirements in §257.73(d)(1)(iv).

---

<sup>1</sup> As modified by court order issued June 14, 2016, *Utility Solid Waste Activities Group v. EPA*, D.C. Cir. No. 15-1219 (order granting remand and vacatur of specific regulatory provisions).

## 2.5 Spillways (§257.73(d)(1)(v))

*CCR unit designed, constructed, operated, and maintained with a single spillway or a combination of spillways configured as specified in [paragraph (A) and (B)]:*

*(A) All spillways must be either:*

- (1) of non-erodible construction and designed to carry sustained flows; or*
- (2) earth- or grass-lined and designed to carry short-term, infrequent flows at non-erosive velocities where sustained flows are not expected.*

*(B) The combined capacity of all spillways must adequately manage flow during and following the peak discharge from a:*

- (1) Probable maximum flood (PMF) for a high hazard potential CCR surface impoundment; or*
- (2) 1000-year flood for a significant hazard potential CCR surface impoundment; or*
- (3) 100-year flood for a low hazard potential CCR surface impoundment.*

The spillway was evaluated using design drawings, information about operations and maintenance, and conditions observed in the field by AECOM. Additionally, hydrologic and hydraulic analyses were completed to evaluate the capacity of the spillway relative to inflow estimated for the 1,000-year flood event for the significant hazard potential Coal Pile Runoff Pond. The hazard potential classification assessment was performed by Stantec in 2016 in accordance with §257.73(a)(2).

The spillway consists of two, high-density polyethylene (HDPE) pipes, which is a non-erodible material that is designed to carry sustained flows. The capacity of the spillway was evaluated using hydrologic and hydraulic analysis performed per §257.82(a). The analysis found that the spillway can adequately manage flow during peak discharge resulting from the 1,000-year storm event without overtopping of the embankments. The hydrologic and hydraulic analyses are discussed in the *CCR Rule Report: Initial Inflow Design Flood Control System Plan for Coal Pile Runoff Pond at Zimmer Power Station* (October 2016). Any issues with the spillway are repaired and debris or other obstructions are removed from the spillway during operations and maintenance, as appropriate and as evidenced by the conditions observed by AECOM. Therefore, the Coal Pile Runoff Pond meets the requirements in §257.73(d)(1)(v).

## 2.6 Stability and Structural Integrity of Hydraulic Structures (§257.73(d)(1)(vi))

*CCR unit designed, constructed, operated, and maintained with hydraulic structures underlying the base of the CCR unit or passing through the dike of the CCR unit that maintain structural integrity and are free of significant deterioration, deformation, distortion, bedding deficiencies, sedimentation, and debris which may negatively affect the operation of the hydraulic structure.*

The stability and structural integrity of the hydraulic structure penetrating the dike of the Coal Pile Runoff Pond, which includes two HDPE pipe conduits, was evaluated using design drawings, information about operations and maintenance, and conditions observed in the field by AECOM. No other hydraulic structures are known to pass through the dike of or underlie the base of the Coal Pile Runoff Pond.

AECOM's field observations found the HDPE pipes to be free of significant deterioration, deformation, distortion, bedding deficiencies, sedimentation, and debris that may negatively affect the operation of the hydraulic structure. Operations and maintenance practices are in place to remove debris or other obstructions from the hydraulic structures, and address any deficiencies, as evidenced by conditions observed by AECOM. As a result, these procedures are appropriate for maintaining the hydraulic structures. Therefore, the Coal Pile Runoff Pond meets the requirements in §257.73(d)(1)(vi).

## 2.7 Downstream Slope Inundation/Stability (§257.73(d)(1)(vii))

*CCR unit designed, constructed, operated, and maintained with, for CCR units with downstream slopes which can be inundated by the pool of an adjacent water body, such as a river, stream or lake, downstream slopes that maintain structural stability during low pool of the adjacent water body or sudden drawdown of the adjacent water body.*

The structural stability of the downstream slopes of the Coal Pile Runoff Pond was evaluated by comparing the location of the Coal Pile Runoff Pond relative to adjacent water bodies using published Federal Emergency Management Agency (FEMA) Flood Insurance Rate Maps (FIRM), aerial imagery, conditions observed in the field by AECOM, and sudden drawdown slope stability analyses.

Based on this evaluation, the Ohio River is adjacent to the western downstream slope of the Coal Pile Runoff Pond. No other downstream water bodies such as rivers, streams, or lakes are adjacent to the Coal Pile Runoff Pond. Several adjacent non-CCR surface impoundments are present, but they are not a river, stream, or lake.

A sudden drawdown slope stability analysis was performed for a cross section adjacent to the Ohio River considered critical for sudden drawdown slope stability analysis. The analysis considered drawdown of the pool in the Ohio River from a 100-year flood condition, as found from the FEMA FIRM map, to an empty pool condition, thereby evaluating both sudden drawdown and low pool conditions. The resulting factor of safety was found to satisfy the criteria listed in United States Army Corps of Engineers Engineer Manual 1110-2-1902 for drawdown from normal to empty pool, as factor of safety criteria for sudden drawdown slope stability analysis is not expressly stated as a requirement of §257.73(d)(1)(vii). Therefore, the Coal Pile Runoff Pond meets the requirements listed in §257.73(d)(1)(vii).



### 3 Certification Statement

**CCR Unit:** Zimmer Power Station; Coal Pile Runoff Pond

I, Victor A. Modeer, being a Registered Professional Engineer in good standing in the State of Ohio, do hereby certify, to the best of my knowledge, information, and belief that the information contained in this CCR Rule Report, and the underlying data in the operating record, has been prepared in accordance with the accepted practice of engineering. I certify, for the above-referenced CCR Unit, that the initial structural stability assessment dated October 13, 2016 was conducted in accordance with the requirements of 40 CFR § 257.73(d).

VICTOR A MODEER JR.  
Printed Name

10/13/16  
Date

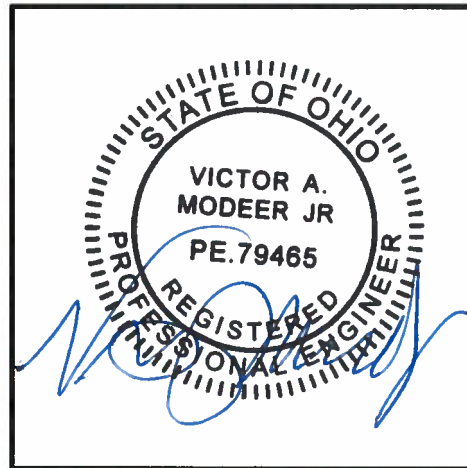



Submitted to  
Zimmer Power Station  
1781 US Route 52  
Moscow, OH 45153

Submitted by  
AECOM  
1001 Highlands Plaza Drive West  
Suite 300  
St. Louis, MO 63110

October 2016

# CCR Rule Report: Initial Structural Stability Assessment

For

Gypsum Recycle Pond  
At Zimmer Power Station

This Coal Combustion Residual (CCR) Rule Report documents that the Gypsum Recycle Pond at the Zimmer Power Station is exempt from the structural stability assessment requirements specified in 40 Code of Federal Regulations (CFR) §257.73(d). The Gypsum Recycle Pond is located near Moscow, Ohio in Clermont County, approximately 0.1 miles northeast of the Zimmer Power Station. The Gypsum Recycle Pond serves as a storage pond for miscellaneous CCRs from wash-down collection systems and stormwater runoff at the Zimmer Power Station.

The Gypsum Recycle Pond is an incised CCR surface impoundment, as defined in 40 CFR 257.53. Under 40 CFR §257.73(b) structural stability assessments (§257.73(d)) must be performed for an existing CCR surface impoundment that:

- 1. Has a height of five feet or more and a storage volume of 20 acre-feet or more; or*
- 2. Has a height of 20 feet or more.*

The Gypsum Recycle Pond does not satisfy the criteria of §257.73(b) because the incised impoundment does not have dikes. Therefore, the Gypsum Recycle Pond is not subject to the structural stability assessment requirements under §257.73(d).





Submitted to  
Zimmer Power Station  
1781 US Route 52  
Moscow, OH 45153

Submitted by  
AECOM  
1001 Highlands Plaza Drive West  
Suite 300  
St. Louis, MO 63110

October 2016

# CCR Rule Report: Initial Structural Stability Assessment

For

D Basin

At Zimmer Power Station

# 1 Introduction

This Coal Combustion Residual (CCR) Rule Report documents that the D Basin at the Zimmer Power Station meets the structural stability assessment requirements specified in 40 Code of Federal Regulations (CFR) §257.73(d). The D Basin is located near Moscow, Ohio in Clermont County, approximately 0.5 miles north of the Zimmer Power Station. The D Basin serves as a dewatering basin for CCR produced by the Zimmer Power Station.

The D Basin is an existing CCR surface impoundment as defined by 40 CFR §257.53. The CCR Rule requires that an initial structural stability assessment for an existing CCR surface impoundment be completed by October 17, 2016. In general, the initial structural stability assessment must document that the design, construction, operation, and maintenance of the CCR unit is consistent with recognized and generally accepted good engineering practices.

The owner or operator of the CCR unit must obtain a certification from a qualified professional engineer stating that the initial structural stability assessment was conducted in accordance with the requirements of 40 CFR § 257.73(d). The owner or operator must prepare a periodic structural stability assessment every five years.

## 2 Initial Structural Stability Assessment

### *40 CFR §257.73(d)(1)*

*The owner or operator of the CCR unit must conduct initial and periodic structural stability assessments and document whether the design, construction, operation, and maintenance of the CCR unit is consistent with recognized and generally accepted good engineering practices for the maximum volume of CCR and CCR wastewater which can be impounded therein. The assessment must, at a minimum, document whether the CCR unit has been designed, constructed, operated, and maintained with [the standards in (d)(1)(i)-(vii)].*

An initial structural stability assessment has been performed to document that the design, construction, operation and maintenance of the D Basin is consistent with recognized and generally accepted good engineering practices and meets the standards in 257.73(d)(1)(i)-(vii). The results of the structural stability assessment are discussed in the following sections. Based on the assessment and its results, the design, construction, operation, and maintenance of the D Basin were found to be consistent with recognized and generally accepted good engineering practices.

### **2.1 Foundations and Abutments (§257.73(d)(1)(i))**

*CCR unit designed, constructed, operated, and maintained with stable foundations and abutments.*

The stability of the foundations was evaluated using soil data from field investigations and reviewing design drawings, information about operations and maintenance, and conditions observed in the field by AECOM. Additionally, slope stability analyses were performed to evaluate slip surfaces passing through the foundations. The D Basin is a ring dike structure and does not have abutments.

The foundation consists of soft to stiff alluvial soil overlying medium dense to very dense alluvial soil. Slope stability analyses exceed the criteria listed in §257.73(e)(1) for slip surfaces passing through the foundation. The slope stability analyses are discussed in the *CCR Rule Report: Initial Safety Factor Assessment for D Basin at Zimmer Power Station* (October 2016). Additional slope stability analyses were performed to evaluate the effects of cyclic softening in the foundation, and were found to satisfy the criteria in §257.73(e)(1)(iv) applicable to dikes. A review of information about operations and maintenance as well as current and past performance of the dikes has determined appropriate processes are in place for continued operational performance.

Based on the conditions observed by AECOM, the D Basin was designed and constructed with stable foundations. Any issues related to the stability of the foundation is addressed during operations and maintenance; therefore, the D Basin meets the requirements in §257.73(d)(1)(i).

### **2.2 Slope Protection (§257.73(d)(1)(ii))**

*CCR unit designed, constructed, operated, and maintained with adequate slope protection to protect against surface erosion, wave action and adverse effects of sudden drawdown.*

The adequacy of slope protection was evaluated by reviewing design drawings, information about operations and maintenance, and conditions observed in the field by AECOM.

Based on this evaluation, adequate slope protection was designed and constructed at the D Basin. No evidence of significant areas of erosion or wave action were observed. Under normal operating conditions there is no free water present within the D Basin. The interior slopes are protected vegetation and a bottom ash protection layer. The exterior slopes are protected with vegetation. The bottom ash protection layer on the interior slopes isolates



the embankment soils from surface erosion, wave action, and acts as a free-draining material that is not susceptible to the adverse effects of sudden drawdown. Therefore, the D Basin meets the requirements in §257.73(d)(1)(ii).

### **2.3 Dike Compaction (§257.73(d)(1)(iii))**

*CCR unit designed, constructed, operated, and maintained with dikes mechanically compacted to a density sufficient to withstand the range of loading conditions in the CCR unit.*

The density of the dike materials was evaluated using soil data from field investigations and reviewing design drawings, information about operations and maintenance, and conditions observed in the field by AECOM. Additionally, slope stability analyses were performed to evaluate slip surfaces passing through the dike over the range of expected loading conditions as defined within §257.73(e)(1).

Based on this evaluation, the dike consists of medium dense to very dense material, which is indicative of mechanically compacted dikes. Slope stability analyses exceed the criteria listed in §257.73(e)(1) for slip surfaces passing through the dike. The slope stability analyses are discussed in the *CCR Rule Report: Initial Safety Factor Assessment for D Basin at Zimmer Power Station* (October 2016); therefore, the original design and construction of the D Basin included sufficient dike compaction. Deficiencies related to compaction of the dikes are identified and mitigated as part of operations and maintenance, in order to maintain sufficient compaction and density of the dikes to withstand the range of loading conditions. Therefore, the D Basin meets the requirements in §257.73(d)(1)(iii).

### **2.4 Vegetated Slopes (§257.73(d)(1)(iv))<sup>1</sup>**

*CCR unit designed, constructed, operated, and maintained with vegetated slopes of dikes and surrounding areas, except for slopes which have an alternate form or forms of slope protection.*

The adequacy of slope vegetation was evaluated by reviewing design drawings, information about operations and maintenance, and conditions observed in the field by AECOM.

Based on this evaluation, the vegetation on the exterior slopes, and vegetation where present on the interior slopes, is adequate as no substantial bare or overgrown areas were observed. Where vegetation is not present on the interior slopes, the bottom ash protection layer is used as an alternate form of slope protection, which is adequate as significant areas of erosion or wave action were not observed. Therefore, the original design and construction of the D Basin included adequate vegetation of the dikes and surrounding areas. Adequate information about operations and maintenance are in place to regularly manage vegetation growth, including mowing and seeding any bare areas, as evidenced by the conditions observed by AECOM. Therefore, the D Basin meets the requirements in §257.73(d)(1)(iv).

---

<sup>1</sup> As modified by court order issued June 14, 2016, *Utility Solid Waste Activities Group v. EPA*, D.C. Cir. No. 15-1219 (order granting remand and vacatur of specific regulatory provisions).

## 2.5 Spillways (§257.73(d)(1)(v))

*CCR unit designed, constructed, operated, and maintained with a single spillway or a combination of spillways configured as specified in [paragraph (A) and (B)]:*

*(A) All spillways must be either:*

- (1) of non-erodible construction and designed to carry sustained flows; or*
- (2) earth- or grass-lined and designed to carry short-term, infrequent flows at non-erosive velocities where sustained flows are not expected.*

*(B) The combined capacity of all spillways must adequately manage flow during and following the peak discharge from a:*

- (1) Probable maximum flood (PMF) for a high hazard potential CCR surface impoundment; or*
- (2) 1000-year flood for a significant hazard potential CCR surface impoundment; or*
- (3) 100-year flood for a low hazard potential CCR surface impoundment.*

The §257.73(d)(1)(v)(A) requirements are not applicable to the D Basin at the Zimmer Power Station because a spillway is not present. However, the §257.73(d)(1)(v)(B) requirement was evaluated to determine if the D Basin meets the requirements without a spillway system present, as discussed below.

The ability of the D Basin to adequately manage flow without a spillway system was evaluated using hydrologic and hydraulic analysis performed per §257.82(a). The analysis found that the D Basin can adequately manage flow during peak discharge resulting from the 1,000-year storm event without overtopping of the embankments. The hazard potential classification assessment was performed by Stantec in 2016 in accordance with §257.73(a)(2). The hydrologic and hydraulic analyses are discussed in the *CCR Rule Report: Initial Inflow Design Flood Control System Plan for D Basin at Zimmer Power Station* (October 2016). Therefore, the D Basin meets the requirements in §257.73(d)(1)(v)(B), even though a spillway system is not present.

## 2.6 Stability and Structural Integrity of Hydraulic Structures (§257.73(d)(1)(vi))

*CCR unit designed, constructed, operated, and maintained with hydraulic structures underlying the base of the CCR unit or passing through the dike of the CCR unit that maintain structural integrity and are free of significant deterioration, deformation, distortion, bedding deficiencies, sedimentation, and debris which may negatively affect the operation of the hydraulic structure.*

Based on an evaluation of design drawings, information about operations and maintenance, and conditions observed in the field by AECOM, no hydraulic structures are present that underlie the base or pass through the dike of the D Basin. Therefore, the §257.73(d)(1)(vi) requirements are not applicable to the D Basin.

## 2.7 Downstream Slope Inundation/Stability (§257.73(d)(1)(vii))

*CCR unit designed, constructed, operated, and maintained with, for CCR units with downstream slopes which can be inundated by the pool of an adjacent water body, such as a river, stream or lake, downstream slopes that maintain structural stability during low pool of the adjacent water body or sudden drawdown of the adjacent water body.*

The structural stability of the downstream slopes of the D Basin was evaluated by comparing the location of the D Basin relative to adjacent water bodies using published Federal Emergency Management Agency (FEMA) Flood Insurance Rate Maps (FIRM), aerial imagery, conditions observed in the field by AECOM, and sudden drawdown slope stability analyses.

Based on this evaluation, the Ohio River is adjacent to the western downstream slope of the D Basin. No other downstream water bodies are adjacent to the D Basin. The adjacent C and B Basins do not retain a pool that inundates the downstream slope of the D Basin during normal conditions.

A sudden drawdown slope stability analysis was performed at a cross-section considered critical for sudden drawdown slope stability analysis. The analysis considered drawdown of the pool in the Ohio River from a 100-year flood condition, as found from the FEMA FIRM map, to an empty pool condition, thereby evaluating both

sudden drawdown and low pool conditions. The resulting factor of safety was found to satisfy the criteria listed in United States Army Corps of Engineers Engineer Manual 1110-2-1902 for drawdown from normal to low pool, as factor of safety criteria for sudden drawdown slope stability analysis is not expressly stated as a requirement of §257.73(d)(1)(vii). Therefore, the D Basin meets the requirements listed in §257.73(d)(1)(vii).



### 3 Certification Statement

CCR Unit: Zimmer Power Station; D Basin

I, Victor A. Modeer, being a Registered Professional Engineer in good standing in the State of Ohio, do hereby certify, to the best of my knowledge, information, and belief that the information contained in this CCR Rule Report, and the underlying data in the operating record, has been prepared in accordance with the accepted practice of engineering. I certify, for the above-referenced CCR Unit, that the initial structural stability assessment dated October 13, 2016 was conducted in accordance with the requirements of 40 CFR § 257.73(d).

VICTOR A MODEER JR.  
Printed Name

10/13/16  
Date

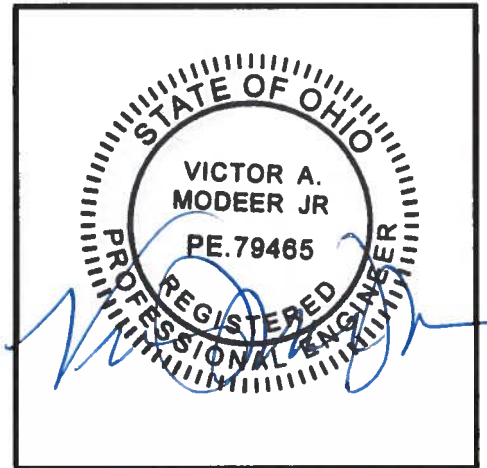

## **APPENDIX C7 – SAFETY FACTOR ASSESSMENT**



Submitted to  
Zimmer Power Station  
1781 US Route 52  
Moscow, OH 45153

Submitted by  
AECOM  
1001 Highlands Plaza Drive West  
Suite 300  
St. Louis, MO 63110

October 2016

# CCR Rule Report: Initial Safety Factor Assessment

For

Coal Pile Runoff Pond

At Zimmer Power Station



# 1 Introduction

This Coal Combustion Residual (CCR) Rule Report documents that the Coal Pile Runoff Pond at the Zimmer Power Station meets the safety factor assessment requirements specified in 40 Code of Federal Regulations (CFR) §257.73(e). The Coal Pile Runoff Pond is located near Moscow, Ohio in Clermont County, approximately 0.6 miles north of the Zimmer Power Station. The Coal Pile Runoff Pond receives leachate from the Zimmer Power Station's on-site landfill, discharge from the Chemical Metal Cleaning waste treatment tank, and pumped flows from the D Basin CCR surface impoundment and other non-CCR ponds at Zimmer Power Station.

The Coal Pile Runoff Pond is an existing CCR surface impoundment as defined by 40 CFR §257.53. The CCR Rule requires that the initial safety factor assessment for an existing CCR surface impoundment be completed by October 17, 2016.

The owner or operator of the CCR unit must obtain a certification from a qualified professional engineer stating that the initial safety factor assessment meets the requirements of 40 CFR § 257.73(e). The owner or operator must prepare a safety factor assessment every five years.

## 2 Initial Safety Factor Assessment

### 40 CFR §257.73(e)(1)

The owner or operator must conduct initial and periodic safety factor assessments for each CCR unit and document whether the calculated factors of safety for each CCR unit achieve the minimum safety factors specified in (e)(1)(i) through (iv) of this section for the critical cross section of the embankment. The critical cross section is the cross section anticipated to be the most susceptible of all cross sections to structural failure based on appropriate engineering considerations, including loading conditions. The safety factor assessments must be supported by appropriate engineering calculations.

(i) The calculated static factor of safety under the long-term, maximum storage pool loading condition must equal or exceed 1.50.

(ii) The calculated static factor of safety under the maximum surcharge pool loading condition must equal or exceed 1.40.

(iii) The calculated seismic factor of safety must equal or exceed 1.00.

(iv) For dikes constructed of soils that have susceptibility to liquefaction, the calculated liquefaction factor of safety must equal or exceed 1.20.

A geotechnical investigation program and stability analyses were performed to evaluate the design, performance, and condition of the earthen dikes of the Coal Pile Runoff Pond. The exploration consisted of hollow-stem auger borings and laboratory program including strength and index testing. Data collected from the geotechnical investigation, available design drawings, construction records, inspection reports, previous engineering investigations, and other pertinent historic documents were utilized to perform the safety factor assessment and geotechnical analyses.

In general, the subsurface conditions at the Coal Pile Runoff Pond consist of very stiff to hard clay embankment fill underlain by medium stiff to hard alluvial clay. The alluvial clay layer is underlain by a layer of medium dense to very dense sand and gravel extending to bedrock. Phreatic water is within the foundation soils of the Coal Pile Runoff Pond.

Three (3) representative cross sections were analyzed using limit equilibrium slope stability analysis software to evaluate stability of the perimeter dike system and foundations. The cross sections were located to represent critical surface geometry, subsurface stratigraphy, and phreatic conditions across the site. Each cross section was evaluated for each of the loading conditions stipulated in §257.73(e)(1).

The Soils Susceptible to Liquefaction loading condition, §257.73(e)(1)(iv), was not evaluated because a liquefaction susceptibility evaluation did not find soils susceptible to liquefaction within the Coal Pile Runoff Pond dikes. As a result, this loading condition is not applicable to the Coal Pile Runoff Pond.

Results of the Initial Safety Factor Assessments, for the critical cross-section for each loading condition (i.e. the lowest calculated factor of safety out of the cross sections analyzed for each condition), are listed in **Table 1**.

**Table 1 – Summary of Initial Safety Factor Assessments**

Loading Conditions	§257.73(e)(1) Subsection	Minimum Factor of Safety	Calculated Factor of Safety
Maximum Storage Pool Loading	(i)	1.50	2.28
Maximum Surcharge Pool Loading	(ii)	1.40	2.28
Seismic	(iii)	1.00	1.60
Soils Susceptible to Liquefaction	(iv)	1.20	Not Applicable

Based on this evaluation, the Coal Pile Runoff Pond meets the requirements in §257.73(e)(1).

### 3 Certification Statement

**CCR Unit:** Zimmer Power Station; Coal Pile Runoff Pond

I, Victor A. Modeer, being a Registered Professional Engineer in good standing in the State of Ohio, do hereby certify, to the best of my knowledge, information, and belief that the information contained in this CCR Rule Report, and the underlying data in the operating record, has been prepared in accordance with the accepted practice of engineering. I certify, for the above-referenced CCR Unit, that the initial safety factor assessment dated October 13, 2016 meets the requirements of 40 CFR §257.73(e).

VICTOR A MODEER JR.  
Printed Name

10/13/14  
Date

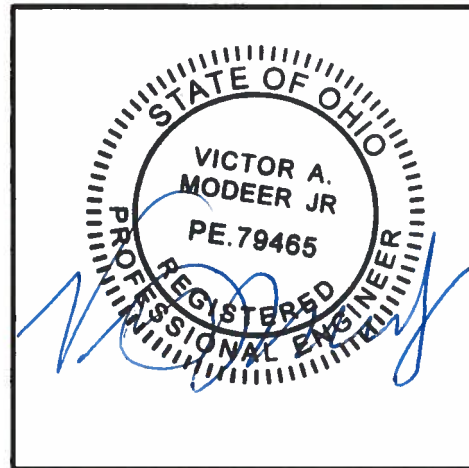





Submitted to  
Zimmer Power Station  
1781 US Route 52  
Moscow, OH 45153

Submitted by  
AECOM  
1001 Highlands Plaza Drive West  
Suite 300  
St. Louis, MO 63110

October 2016

# CCR Rule Report: Initial Safety Factor Assessment

For

Gypsum Recycle Pond  
At Zimmer Power Station

This Coal Combustion Residual (CCR) Rule Report documents that the Gypsum Recycle Pond at the Zimmer Power Station is exempt from the safety factor assessment requirements specified in 40 Code of Federal Regulations (CFR) §257.73(e). The Gypsum Recycle Pond is located near Moscow, Ohio in Clermont County, approximately 0.1 miles northeast of the Zimmer Power Station. The Gypsum Recycle Pond serves as a storage pond for miscellaneous CCRs from wash-down collection systems and stormwater runoff at the Zimmer Power Station.

The Gypsum Recycle Pond is an incised CCR surface impoundment as defined by 40 CFR 257.53. Under 40 CFR §257.73(b), a safety factor assessment (§257.73(e)) must be performed for an existing CCR surface impoundment that:

- 1. Has a height of five feet or more and a storage volume of 20 acre-feet or more; or*
- 2. Has a height of 20 feet or more.*

The Gypsum Recycle Pond does not satisfy the criteria of §257.73(b) because the incised impoundment does not have dikes. Therefore, the Gypsum Recycle Pond is not subject to safety factor assessment requirements under §257.73(e).



Submitted to  
Zimmer Power Station  
1781 US Route 52  
Moscow, OH 45153

Submitted by  
AECOM  
1001 Highlands Plaza Drive West  
Suite 300  
St. Louis, MO 63110

October 2016

# CCR Rule Report: Initial Safety Factor Assessment

For

D Basin

At Zimmer Power Station



# 1 Introduction

This Coal Combustion Residual (CCR) Rule Report documents that the D Basin at the Zimmer Power Station meets the safety factor assessment requirements specified in 40 Code of Federal Regulations (CFR) §257.73(e). The D Basin is located near Moscow, Ohio in Clermont County, approximately 0.5 miles north of the Zimmer Power Station. The D Basin serves as a dewatering basin for CCR produced by the Zimmer Power Station.

The D Basin is an existing CCR surface impoundment as defined by 40 CFR §257.53. The CCR Rule requires that the initial safety factor assessment for an existing CCR surface impoundment be completed by October 17, 2016.

The owner or operator of the CCR unit must obtain a certification from a qualified professional engineer stating that the initial safety factor assessment meets the requirements of 40 CFR § 257.73(e). The owner or operator must prepare a safety factor assessment every five years.

## 2 Initial Safety Factor Assessment

### 40 CFR §257.73(e)(1)

The owner or operator must conduct initial and periodic safety factor assessments for each CCR unit and document whether the calculated factors of safety for each CCR unit achieve the minimum safety factors specified in (e)(1)(i) through (iv) of this section for the critical cross section of the embankment. The critical cross section is the cross section anticipated to be the most susceptible of all cross sections to structural failure based on appropriate engineering considerations, including loading conditions. The safety factor assessments must be supported by appropriate engineering calculations.

(i) The calculated static factor of safety under the long-term, maximum storage pool loading condition must equal or exceed 1.50.

(ii) The calculated static factor of safety under the maximum surcharge pool loading condition must equal or exceed 1.40.

(iii) The calculated seismic factor of safety must equal or exceed 1.00.

(iv) For dikes constructed of soils that have susceptibility to liquefaction, the calculated liquefaction factor of safety must equal or exceed 1.20.

A geotechnical investigation program and stability analyses were performed to evaluate the design, performance, and condition of the earthen dikes of the D Basin. The exploration consisted of hollow-stem auger borings and laboratory program including strength, hydraulic conductivity, and index testing. Data collected from the geotechnical investigation, available design drawings, construction records, inspection reports, previous engineering investigations, and other pertinent historic documents were utilized to perform the safety factor assessment and geotechnical analyses.

In general, the subsurface conditions at the D Basin consist of medium dense to dense sand overlying soft to stiff alluvial clay, which in turn overlies medium dense to very dense sand and gravel. Phreatic water is within the foundation of the D Basin.

A critical cross section was analyzed using limit equilibrium slope stability analysis software to evaluate stability of the perimeter dike system and foundations. The cross section was located at the maximum embankment height for the D Basin. Due to the relatively short height of the D Basin embankments and uniform slope orientations, subsurface stratigraphy, and phreatic conditions, a cross section at the maximum embankment height is sufficient to represent the critical cross section. The cross section was evaluated for each of the loading conditions stipulated in §257.73(e)(1).

The Soils Susceptible to Liquefaction loading condition, §257.73(e)(1)(iv), was not evaluated because a liquefaction susceptibility evaluation did not find soils susceptible to liquefaction within the D Basin dikes. As a result, this loading condition is not applicable to the D Basin.

Results of the Initial Safety Factor Assessments are listed in **Table 1**.

**Table 1 – Summary of Initial Safety Factor Assessments**

Loading Conditions	§257.73(e)(1) Subsection	Minimum Factor of Safety	Calculated Factor of Safety
Maximum Storage Pool Loading	(i)	1.50	3.88
Maximum Surcharge Pool Loading	(ii)	1.40	2.63
Seismic	(iii)	1.00	1.79
Soils Susceptible to Liquefaction	(iv)	1.20	Not Applicable

Based on this evaluation, the D Basin meets the requirements in §257.73(e)(1).

### 3 Certification Statement

**CCR Unit:** Zimmer Power Station; D Basin

I, Victor A. Modeer, being a Registered Professional Engineer in good standing in the State of Ohio, do hereby certify, to the best of my knowledge, information, and belief that the information contained in this CCR Rule Report, and the underlying data in the operating record, has been prepared in accordance with the accepted practice of engineering. I certify, for the above-referenced CCR Unit, that the initial safety factor assessment dated October 13, 2016 meets the requirements of 40 CFR §257.73(e).

VICTOR A MODEER JR.  
Printed Name

10/13/16  
Date







CREATE AMAZING.

Burns & McDonnell World Headquarters  
9400 Ward Parkway  
Kansas City, MO 64114  
O 816-333-9400  
F 816-333-3690  
[www.burnsmcd.com](http://www.burnsmcd.com)